



IOT MANHOLE MONITORING & STREET LIGHT CONTROL SYSTEM WITH FAULT DETECTION & REPORTING FOR MUNICIPALITIES

Dr. Usthulamuri Penchalaiah Department of Electronics and Communication Engineering, Geethanjali Institute of Science and Technology, Nellore.

Shaik Arshad Department of Electronics and Communication Engineering, Geethanjali Institute of Science and Technology, Nellore.

Mudipalli Satish Department of Electronics and Communication Engineering, Geethanjali Institute of Science and Technology, Nellore.

Mannepalli Venkatesh Department of Electronics and Communication Engineering, Geethanjali Institute of Science and Technology, Nellore.

Nakkala Uma Mahesh Department of Electronics and Communication Engineering, Geethanjali Institute of Science and Technology, Nellore.

ABSTRACT

This project involves the design and implementation of an automated street light control system and an underground drainage monitoring system using IOT technology. Besides this, it can also check the status of the manhole lid. The system's low maintenance and low cost are some of its main advantages. This system can monitor the status of the street lights and manholes in real time. It can also notify the officials through a text message. The IoT (Internet of Things) is a blooming technology that mainly concentrates on the interconnection of devices to one another and the people. The world is getting smarter these days, and people are drawn to the word "Smart". Given that India is one of the world's fastest-growing tech markets, we are incorporating a smart framework into the switch. The project's goal is to provide automatic control and fault detection for street light. The lights are switched ON/OFF automatically based on the intensity of sunlight using the LDR sensor. Smart underground infrastructure is an important feature to be considered while implementing Drainage system monitoring plays a vital role in keeping the city clean and healthy. Since manual monitoring is incompetent, this leads to slow handling of problems in drainage and consumes more time to solve. To mitigate all these issues, the system using a wireless sensor network, consisting of sensor nodes is designed. The proposed system is low cost, low maintenance, IoT based real time which alerts the managing station through a message when any manhole crosses its threshold values. This system reduces the death risk of manual scavengers who clean the underground drainage and also benefits the public.

Keywords:

Manhole Monitoring, Street Light Control System, Fault Detection, Municipalities, Cost-effective LDR Sensor (Light Dependent Resistor), Smart Infrastructure

1.INTRODUCTION

An embedded system is a particular type of computer system that is primarily made to carry out several activities, including accessing, processing, storing, and controlling the data in various electronics-based systems. Embedded systems are made up of both hardware and software, with the software—often referred to as firmware—being integrated directly into the hardware. These systems' ability to provide the o/p within the allotted time is one of their most crucial qualities. Embedded systems assist in improving the accuracy and convenience of the task. So, both basic and complex gadgets routinely use embedded systems. The principal real-world uses for embedded systems are in a variety of appliances, including microwaves, calculators, TV remote controls, home security systems, and local traffic management systems. An integral part of any drainage system is the access points into it when it comes to cleaning, clearing, and inspection. Metropolitan cities have adopted underground drainage systems and the city's municipal corporation must maintain its cleanliness. If the sewage maintenance



is not proper, ground water gets contaminated causing infectious diseases. Blockages drains during monsoon season, causing problems in the routine of the public. Hence, there should be a facility in the city's corporation, which alerts the officials about blockages in sewers, their exact location. It mainly acknowledges in the field of alerting the people about the gas explosion, increase in the water level and the temperature level. It uses IoT to make the drainage monitoring system in a highly automotive by using sensor for detecting and sending alerts through GSM and GPS module to the authorities. This project overcomes the demerits by detecting drainage water blockage by installing water flow rate sensors at the intersection of nodes. When there is a blockage in a particular node, there is variation in the flow of drainage water which when cross the set value will display the alert in the managing station. Also other demerits are solved by detecting.

PROBLEM STATEMENT

Developing an integrated IoT solution that combines sensors for manhole monitoring, smart street light controllers, and a centralized platform for fault detection and reporting. The system should enable real-time monitoring of manhole conditions, adaptive control of street lights, and automated fault detection with timely reporting. This solution aims to improve municipal infrastructure management, reduce maintenance costs, enhance public safety, and contribute to energy efficiency in urban areas.

Municipalities face challenges in efficiently managing urban infrastructure, particularly in monitoring the condition of manholes and controlling street lights. The existing systems often lack real-time data, leading to delayed responses to faults, increased maintenance costs, and inefficient energy usage. To address these issues, there is a need for an integrated IoT Manhole Monitoring & Street Light Control System with Fault Detection & Reporting for Municipalities.

1)Manhole Condition Monitoring:

Lack of real-time data on the condition of manholes. Inability to detect issues such as blockages, overflows, or structural damage promptly. Delayed response to manhole-related problems, leading to environmental and safety concerns.

2)Street Light Control:

Inefficient energy usage due to fixed schedules or manual control. Difficulty in promptly identifying and addressing malfunctions or outages. Inability to adapt to changing environmental conditions, leading to unnecessary energy consumption.

3)Fault Detection & Reporting:

Absence of a systematic approach for detecting faults in manholes and street lights. Limited capability to generate real-time reports on faults and their locations. Lack of automated notification systems for timely response and preventive maintenance.

4)Data Integration and Accessibility:

Inconsistent data integration across various municipal systems. Limited accessibility to relevant data for informed decision-making. Absence of a centralized platform for monitoring and managing both manholes and street lights.

5)Cost Inefficiencies:

High maintenance costs due to reactive rather than proactive maintenance. Unoptimized energy costs for street lighting. Increased operational expenses resulting from delayed fault detection and resolution.

2.LITERATURE REVIEW

S. Sulthana et.al (2020) [1] Everyone has the right to live in a healthy environment. Flooding due to obstructed drains is a common phenomenon in Bangladesh and many other developing countries, leading to unhygienic surroundings. The air becomes poisoned due to sewage gas, resulting in health issues. Stagnant water on roads contributes to the growth of Aedes mosquitoes. Manual tracking of drain conditions is challenging, and issues often become apparent only after widespread flooding occurs. To address this, the paper proposes a warning system that utilizes GSM techniques and IoT. The system employs sensors such as MQ135 for sewage gas, an ultrasonic sensor for measuring



sewage distance, and a water level sensor to monitor water flow. When the water level reaches a certain threshold, the system sends a text message to the authorities, pinpointing the affected areas using GPS coordinates. Additionally, real-time data can be accessed by both authorities and the public through an online website implemented using NodeMCU.

A. Pendharkar et.al (2020) [2] This project aims to develop an IoT-based technology for monitoring sewage systems. The system detects humidity levels, temperature, and gas mixtures in real-time. It utilizes various sensors to measure gas concentrations and dynamically track changes. Specifically, it focuses on ensuring the safety of workers who operate under severe conditions. When gas levels exceed predefined thresholds, the system sends alerts to authorized personnel via connected mobile devices. Additionally, live video streaming allows monitoring for blockages.

U. Andrijašević et.al (2020) [3] this paper, the machine learning algorithm for lid opening detection in telecommunication manholes is presented. Telecommunication manholes network is equipped with smart Internet of Things (IoT) devices that use multiple sensors to monitor the system and detect various states of a manhole, such as lid opening, light detection, and object or person presence. The machine learning algorithm, developed with a recurrent neural network (RNN), specifically long short-term memory (LSTM), detects whether the lid is open or closed based on the data generated by the IoT manhole monitoring system.

P. Bhosale et.al (2021) [4] smart cities, the Internet of Things (IoT) plays a crucial role in providing seamless and unique access to public resources, aiming for better utilization and optimization of power, water, and transportation facilities. Urban India faces a water crisis, with approximately 80% of sewage entering lakes, rivers, and groundwater untreated due to ineffective wastewater infrastructure management. This research focuses on monitoring sewage infrastructure to predict blockages and prevent them from escalating into Sanitary Sewer Overflows (SSO). The proposed IoT-based system tackles this issue comprehensively. It monitors the working of access manholes in a network, collecting multiple data parameters generated in and around these manholes. When the development of a blockage is detected, the system sends alerts. This geospatial data, along with the alerts, is observed via a centralized visual dashboard.

M. Aarthi et.al (2021) [5] The issue of drainage overflow is a significant concern in major cities, often caused by blockages. If left unresolved, it can lead to unhygienic conditions and health problems for nearby residents. To address this, an innovative system has been proposed. Additionally, a manhole monitoring system is integrated. When water flow is hindered due to sewage blockage, foul odors emanate from the manhole. These odors are produced by dangerous gases associated with stagnant dirty water. This system contributes to efficient sewage management, preventing blockages and promoting public health.

S.A. Shamikh et.al (2017) [6] The underground drainage system is a crucial component of urban infrastructure, serving as the lifeline of cities. However, manual management of drainage systems is inefficient, and maintaining clean and functional underground systems poses challenges. Accurate assessment of manhole covers, detection of blockages, and monitoring of toxic gases are essential for public health and safety. This project focuses on monitoring and managing underground and road-sided drainage systems using IoT and Raspberry Pi. his innovative system contributes to efficient sewage management, early detection of issues, and healthier urban environments.

Muragesh Sk et.al (2015) [7] has revolutionized real-world interactions by connecting physical objects and devices to sensor networks. In the context of urban infrastructure, efficient drainage management is crucial for maintaining cleanliness and preventing contamination. This paper presents the implementation and design of an Underground Drainage and Manhole Monitoring System (UDMS) for IoT applications. The key considerations in this design include low cost, low maintenance, rapid deployment, a high number of sensors, long life, and high-quality service. Efficient monitoring of manholes using sensors contributes to healthier urban environments and proactive maintenance.

Lazarescu, M.T., et.al (2013) [8] designed the Internet of Things (IoT) provides a virtual view, via the Internet Protocol, to a wide variety of real-life objects, ranging from cars and buildings to trees in a forest. Wireless sensor networks (WSNs) are well-suited for long-term environmental data acquisition, making them ideal for representing IoT applications. This paper presents the functional design and implementation of a complete WSN platform that can be used for a range of long-term environmental monitoring IoT applications. This innovative WSN platform contributes to efficient and cost-effective environmental monitoring, supporting a healthier and more sustainable future.

3.PROPOSED SYSTEM

In this project, we present a working model of IOT Manhole Monitoring & Street Light control system with fault detection & reporting for Municipalities. The main objective for implementing this project is to enhance the municipalities in terms of Smart infrastructure management, public safety, and resource optimization. Implemented using IOT, Arduino Uno microcontroller, GPS, Ultrasonic sensor, LDR1, LDR2, Street light, RPS, LCD, buzzer, Arduino IDE tool, and embedded c language.

BLOCK DIAGRAM:



The proposed IoT-based system for manhole monitoring and street light control with fault detection and reporting capabilities represents a cutting-edge solution for municipalities to efficiently manage their infrastructure.

In the manhole monitoring aspect, the system would incorporate IoT sensors deployed within manholes across the municipality. These sensors would be equipped to monitor various parameters such as water levels, temperature, gas concentrations, and structural integrity. The sensors would continuously collect data and transmit it wirelessly to a central control hub. This control hub would host a cloud-based platform where the data would be analyzed in real-time using advanced algorithms.

For street light control, the system would involve retrofitting existing street lights with IoT controllers and sensors. These controllers would allow for remote monitoring and control of each street light, enabling municipalities to adjust lighting levels dynamically based on factors such as time of day, weather conditions, and traffic patterns. The sensors would also detect faults such as burnt-out bulbs, electrical issues, or vandalism.

The fault detection and reporting capabilities would be a key feature of the system. In both manhole monitoring and street light control, the system would be programmed to detect anomalies and faults automatically. For manholes, this could include detecting rising water levels, abnormal temperatures, or sudden changes in gas concentrations. For street lights, it could involve identifying burnt-out bulbs, fluctuations in power consumption, or physical damage.



Upon detecting a fault, the system would generate automated alerts and reports. These alerts would be sent to designated personnel responsible for maintenance and repairs. The reports would provide detailed information about the nature of the fault, its location, and any relevant environmental conditions. This would enable maintenance teams to respond promptly and efficiently, minimizing downtime and ensuring the continued operation of critical infrastructure.

Furthermore, the system would offer advanced analytics capabilities. It would store historical data collected from both manhole monitoring and street light control, allowing municipalities to identify trends, predict potential issues, and optimize resource allocation. This data-driven approach would enable municipalities to make informed decisions about infrastructure maintenance, upgrade, and expansion, ultimately enhancing the resilience and sustainability of urban infrastructure networks.

Overall, the proposed IoT-based system for manhole monitoring and street light control with fault detection and reporting represents a comprehensive solution for municipalities seeking to modernize their infrastructure management practices. By leveraging the power of IoT technology and advanced analytics, municipalities can improve the reliability, efficiency, and safety of their infrastructure while minimizing operational costs and environmental impact.

Hardware Modules:

- Sensors
- Microcontroller
- Communication Module
- Light Intensity Sensors
- Fault Detection Sensors
- Database
- User Interface

Software Modules:

- Sensor Integration
- Data Processing
- Remote Control
- APIs (Application Programming Interfaces)
- Alert Generation
- Access Control
- Authentication and Authorization

Project Working:

In this system there are totally five sections:

1. Regulated Power Supply

2. Input Section

- GPS
- Ultrasonic Sensor
- LDR1
- LDR2

3. Output Section

- LCD
- Buzzer
- IOT
- Street Light

4. Arduino Uno Microcontroller

There are five modules Controller, RPS, Input, software and output module. The power is supplied to the RPS module through an adapter. The adapter converts 230v AC to 12v DC and this 12v DC is give UGC CARE Group-1



to the RPS module. The RPS module consists of voltage regulator 7805 which converts the 12v DC into 5v DC, capacitors are used to reduce noise and LED is used which indicates whether the power is supplied or not. This 5v DC power supply goes to each and every module.

The Input modules are GPS, Ultrasonic sensor, LDR1 and LDR2. The GPS is used for live tracking of the system, the Ultrasonic sensor is used for drainage level detection of fault, In LDR1 the street light in day time should be OFF and night time street light should be ON in the system, In LDR2 the fault detection happens.

The output modules are LCD, Buzzer, IOT and street light. The 16x2 LCD module shows the output in the kit. The Buzzer used in the system is piezoelectric buzzer it alerts the system.

The data is uploaded in the website by using ESP8266 IOT module. Street light used in the system is 12v LED.

An IoT-based Manhole Monitoring & Street Light Control System with Fault Detection & Reporting for Municipalities integrates various technologies to enhance the management and maintenance of urban infrastructure. The system begins with the installation of IoT sensors in manholes and streetlights across the city. These sensors are equipped with various capabilities such as measuring water levels, monitoring temperature, and detecting light intensity. They are wirelessly connected to a central control system.

The sensors continuously collect data related to manhole conditions (such as water level, pressure, and presence of toxic gases) and streetlight status (light intensity, power consumption, etc.). This data is transmitted in real-time to the central control system using wireless communication protocols such as Wi-Fi, cellular networks. The central control system, typically located in the municipality's office or a centralized data center, collects and processes the data received from the IoT sensors.

Utilizing advanced algorithms and analytics, the central control system analyzes the data to identify any anomalies or faults in the manholes or streetlights. It continuously monitors the incoming data for deviations from normal operating conditions. If any anomalies or faults are detected, such as a rise in water level in a manhole beyond a certain threshold or a malfunctioning streetlight, the system triggers an alert/notification.

These notifications are sent out to relevant stakeholders, such as municipal authorities, maintenance crews, or utility companies, informing them about the detected fault or anomaly. Notifications can be sent via SMS, email, or through a dedicated dashboard or mobile application. Depending on the severity of the fault or anomaly detected, the system can trigger automated responses.

Furthermore, malfunctioning streetlights can be remotely turned off or dimmed until they are repaired. Municipal authorities can use the data collected by the system to schedule routine maintenance tasks, prioritize repairs, and optimize resource allocation. Overall, an IoT Manhole Monitoring & Street Light Control System with Fault Detection & Reporting enables municipalities to improve the efficiency, safety, and reliability of urban infrastructure while reducing maintenance costs and minimizing downtime.

Schematic Diagram

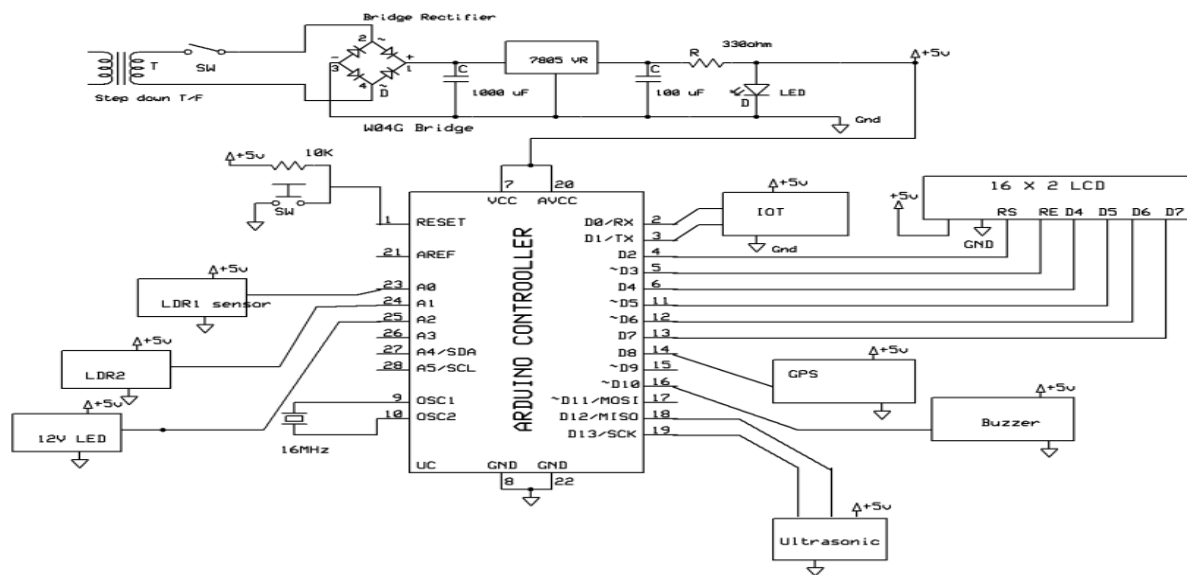

This is the pin diagram where all the hardware components are been connected components. this ARDUINO microcontroller having 28 pins. In which 14 GPIO pins as digital pins and 6 GPIO pins. 16MHz crystal oscillator connected internally. The step down transformer, Bridge rectifier capacitor with 1000f Resistors and led are connected in Regulated power supply which provide the 5v to the Arduino and all input/output modules.

- 16*2 LCD Monitor has connected with the Digital pins 2,3,4,5,6,7.
- WIFI has connected to Digital Pins D0,D1 internal Transmitter and receiver pins.
- Ultrasonic connected to 12, 13 pins of the Arduino micro controller.
- IR sensor connected to digital pin A0
- LDR sensor connected to digital pin A1
- Buzzer alarm connected to digital pin 10
- LED sensor connected to digital pin A2
- GPS connected to digital pin 8

Design and implementation of smart city by using ARDUINO is done with 3 advanced applications smart drainage over flow, and Smart Street lighting system. Municipal drainage level will monitor and updated into over LCD and IOT module. Drainage system we use water detecting sensor which is automatically alert if it sense overflow of water. Street light applications we use LDR sensor along with LED indicator for street light.

ADVANTAGES:

The integration of IoT (Internet of Things) technology in Manhole Monitoring and Street Light Control Systems with Fault Detection & Reporting brings numerous advantages for municipalities.

Here are some key benefits of implementing such systems:

Proactive Maintenance:

The IoT-enabled Manhole Monitoring system allows municipalities to proactively address potential issues in sewer systems. By continuously monitoring parameters such as water levels and pressure, authorities can detect anomalies early on, preventing major failures and minimizing repair costs.

Improved Public Safety:

Street Light Control Systems with Fault Detection & Reporting contribute to enhanced public safety by ensuring well-lit urban environments. The proactive fault detection mechanism identifies malfunctions or outages promptly, reducing the risk of accidents and criminal activities in poorly lit areas.

Energy Efficiency:



The Street Light Control System utilizes IoT technology to optimize energy consumption. By dynamically adjusting lighting levels based on real-time conditions such as pedestrian activity and ambient light levels, municipalities can achieve significant energy savings and contribute to a more sustainable urban environment.

Cost Savings:

Both Manhole Monitoring and Street Light Control Systems lead to cost savings for municipalities. The early detection of faults in sewer systems minimizes the need for emergency repairs, while efficient street lighting management reduces energy costs and maintenance expenses.

Remote Monitoring and Control:

The IoT capabilities enable remote monitoring and control of both manholes and street lights. Municipal authorities can access real-time data, make adjustments, and receive automated reports from a centralized location, improving operational efficiency and reducing the need for physical inspections.

Data-Driven Decision Making:

The systems generate valuable data that can be analyzed to make informed decisions. Municipalities can use the data to optimize resource allocation, plan maintenance schedules, and improve overall infrastructure management.

Enhanced Resilience and Reliability:

The predictive maintenance features of these systems increase the resilience and reliability of critical infrastructure. By identifying potential issues before they escalate, municipalities can ensure the continuous functionality of sewer systems and street lights.

Smart City Integration:

These IoT-enabled systems can be seamlessly integrated into broader smart city initiatives. By connecting different components of urban infrastructure, municipalities can create a more interconnected and efficient urban environment.

Environmental Impact:

The energy optimization features of the Street Light Control System contribute to reducing carbon emissions, aligning with environmental sustainability goals. Additionally, the proactive maintenance of sewer systems helps prevent environmental contamination and mitigates the impact of infrastructure failures.

User-Friendly Interfaces:

The systems are designed with user-friendly interfaces, making them accessible to municipal administrators and operators with varying levels of technical expertise. This ensures effective utilization and management of the IoT-enabled solutions.

DISADVANTAGES:

While IoT (Internet of Things) solutions like Manhole Monitoring and Street Light Control Systems with Fault Detection & Reporting offer several benefits for municipalities, there are also potential disadvantages and challenges associated with their implementation.

Here are some considerations:

Security Concerns:

IoT devices are vulnerable to cyber-attacks, and if not properly secured, malicious actors could gain unauthorized access to the system. This could lead to unauthorized control of street lights, false reporting, or manipulation of data.

Data Privacy Issues:

The collection of data from IoT devices raises concerns about privacy. Monitoring systems may capture sensitive information, and municipalities need to implement robust data protection measures to ensure the privacy of citizens is maintained.

High Initial Costs: Implementing a comprehensive IoT system can be expensive, especially for municipalities with limited budgets. The cost of sensors, communication infrastructure, and software development can be significant.



Maintenance Challenges:

IoT devices and sensors require regular maintenance to ensure proper functionality. Manhole sensors and street light control systems may be exposed to harsh environmental conditions, leading to wear and tear. Frequent maintenance may be needed to keep the system operational.

Compatibility Issues:

Integrating IoT devices from different manufacturers may pose compatibility challenges. Ensuring seamless communication and interoperability between various components of the system can be complex.

Limited Scalability:

Some IoT solutions may have limitations when it comes to scalability. As municipalities grow or change, the system may struggle to adapt to increased demands or additional devices.

Power Consumption:

Many IoT devices rely on batteries or other power sources. Ensuring a stable and sustainable power supply for these devices, especially in remote or inaccessible locations, can be a challenge.

False Alarms and Accuracy:

IoT devices, especially those involved in fault detection, may generate false alarms or inaccurate reports. This could lead to unnecessary maintenance activities or overlook real issues, impacting the overall efficiency of the system.

APPLICATIONS:

The IoT (Internet of Things) Manhole Monitoring & Street Light Control System with Fault Detection & Reporting for municipalities offers a versatile set of applications that significantly improve urban infrastructure management.

Here are some key applications:

Smart City Infrastructure Management:

The system contributes to the development of smart cities by providing real-time monitoring and control of critical components like manholes and street lights. This helps municipalities in making data-driven decisions for better urban planning and resource allocation.

Efficient Street Lighting:

The Street Light Control System optimizes energy consumption by adjusting lighting levels based on real-time factors. This leads to significant energy savings for municipalities, contributing to sustainability goals and reducing operational costs.

Public Safety Enhancement:

The intelligent monitoring of manholes ensures the timely detection of issues such as overflow or blockage, preventing potential hazards and improving public safety. Properly functioning street lights also enhance visibility, contributing to a safer urban environment.

Fault Detection and Reporting:

The Fault Detection & Reporting feature helps municipalities identify issues in both manholes and street lights promptly. This proactive approach enables faster response times for maintenance and repairs, minimizing downtime and improving overall system reliability.

Predictive Maintenance:

The system's predictive maintenance capabilities anticipate potential failures in manholes and street lights based on historical data and analytics. This helps municipalities schedule maintenance activities in advance, reducing the likelihood of unexpected issues and extending the lifespan of infrastructure components.

Environmental Impact Mitigation:

By optimizing energy usage in street lighting and ensuring efficient operation of manholes, the system contributes to reducing the environmental footprint of municipalities. This aligns with sustainability goals and demonstrates a commitment to environmental responsibility.

Traffic Management and Planning:

The real-time data collected from the system can be utilized for intelligent traffic management. By adjusting street lighting based on traffic patterns, municipalities can enhance traffic flow and reduce congestion, leading to improved overall urban mobility.

Remote Monitoring and Control:

The ability to remotely monitor and control both manholes and street lights offers municipalities unprecedented flexibility. Administrators can access the system from anywhere, facilitating timely responses to emerging issues and enabling efficient management of city infrastructure.

Data Analytics for Decision-Making:

The system generates valuable data that can be analyzed to gain insights into usage patterns, performance metrics, and potential areas for improvement. This data-driven approach helps municipalities make informed decisions for better city planning and development.

Integration with Existing Systems:

The flexibility of the system allows seamless integration with other municipal systems, such as traffic management or emergency response systems. This creates a holistic approach to urban infrastructure management, improving overall efficiency and coordination.

4.RESULTS

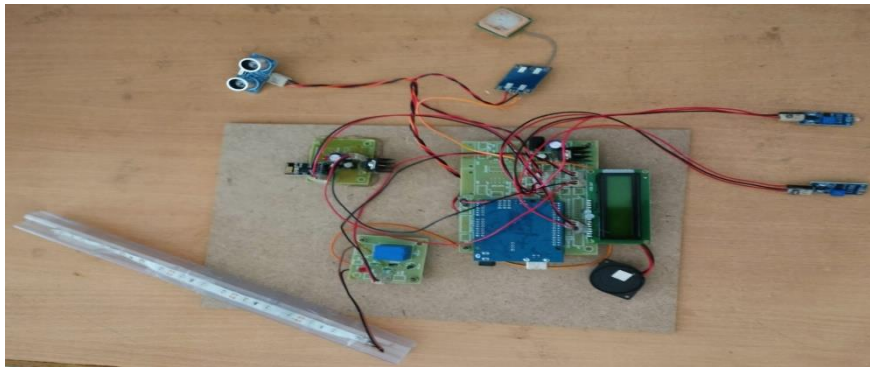

The above image shows the hardware equipment of the project. The kit is turned ON by giving the regulated power supply of 12v which is then converted to 5v dc current. The generated 5v dc current passes to every hardware component in the circuit.

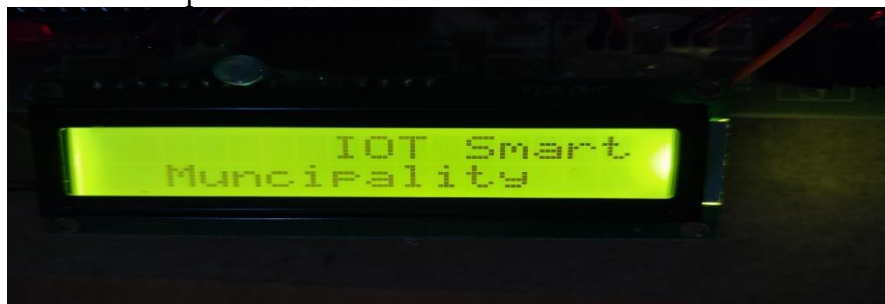

When we turned on the regulated power supply, the LCD displayed the IOT Smart Municipality. The output may be seen in the following image after we have connected to the IOT module.



Here LCD displays the light is in OFF as shown in above picture and Ultrasonic sensor level we can see in the above placed picture how the value is represented.

S.No	Ultrasonic	Drainage_Status	LDR	Light_Fault	Location	Date	
1	2	Drainage_Full	Light	Light_OFF	Location	Location	2024-02-16 12:09:46
2	3	Drainage_Full	Light	Light_OFF	Location	Location	2024-02-16 12:09:26
3	9	Drainage_Full	Light	Light_OFF	Location	Location	2024-02-16 12:09:06
4	2	Drainage_Full	Light	Light_OFF	Location	Location	2024-02-16 12:08:44
5	2	Drainage_Full	Light	Light_OFF	Location	Location	2024-02-16 12:08:24
6	9	Drainage_Full	Light	Light_OFF	Location	Location	2024-02-16 12:08:04
7	76	Drainage_Normal	Dark	Light_Fault	Location	Location	2024-02-16 12:07:41
8	15	Drainage_Normal	Dark	Light_Fault	Location	Location	2024-02-16 12:07:21
9	8	Drainage_Full	Dark	Light_Fault	Location	Location	2024-02-16 12:07:00
10	8	Drainage_Full	Light	Light_OFF	Location	Location	2024-02-16 12:06:40
11	9	Drainage_Full	Light	Light_OFF	Location	Location	2024-02-16 12:06:18
12	77	Drainage_Normal	Dark	Light_Fault	Location	Location	2024-02-16 12:05:54
13	9	Drainage_Full	Dark	Light_Fault	Location	Location	2024-02-16 12:05:28
14	9	Drainage_Full	Light	Light_OFF	Location	Location	2024-02-16 12:05:08
15	5	Drainage_Full	Light	Light_OFF	Location	Location	2024-02-16 12:04:41
16	80	Drainage_Normal	Dark	Light_Fault	Location	Location	2024-02-16 12:04:13
17	8	Drainage_Full	Dark	Light_Fault	Location	Location	2024-02-16 12:03:21
18	8	Drainage_Full	Dark	Light_ON	Location	Location	2024-02-16 12:03:01

Here the image displays the output of the system is uploaded in the website by using ESP8266 IOT. The data of drainage status and street light fault is detected and the locations with date and time are reported to the municipalities.

5.CONCLUSION

We Design and Implement the “IOT-MONHAOLE MONITORING & STREET LIGHT CONTROL SYSTEM WITH FAULT DETECTION AND REPORTING FOR MUNCIPALITIES” The main aim of the project is to benefit municipalities in terms of Smart infrastructure management, public safety, and resource optimization. In this project we are using the RPS, GPS, Ultrasonic sensor, LDR1, LDR2, LCD, Buzzer, Street light , IOT Module transmittin the data .And the data can be controlled by the Arduino Uno Micro Controller .By using the WIFI module connect the IOT Server. The data can display on the LCD display and at the same time IOT server. This system is simple tothe IoT Manhole Monitoring & Street Light Control System represents a transformative solution for municipalities, offering a scalable and cost-effective approach to managing critical infrastructure assets, enhancing public service delivery, and promoting the well-being of urban communities.

REFERENCES

- [1] S Sultana, A Rahaman, AM Jhara, AC Paul “An IOT Based Smart Drain Monitoring System with Alert Messages”-Conference on Intelligent, 2020 Springer.
- [2]A Pendharkar, J Chillapalli, K Dhakate, “IoT Based Sewage Monitoring System”, Available at SSRN, 2020, researchgate.net.
- [3] U Andrijašević, J Kocić, V Nešić, “Lid Opening Detection in Manholes” 2020 - ieexplore.ieee.org.
- [4] P Bhosale, “Iot Based S[y]stem for Detection of Sewage Blockages”, 2021, itin-industry.org.
- [5] M Aarthi, A Bhuvaneshwaran, “Iot Based Drainage and Waste Management Monitoring and Alert System for Smart City”- Annals of the Romanian Society, 2021 - annalsofrscb.ro.
- [6] Prof S. A. Shamikh1, Suvarna A. Sonawane2, ”Monitoring Smart City Application Using Raspberry PI based on IoT ” International Journal of Innovative Science, Engineering & Technology, Vol 5 Issue VII, July 2017.
- [7] Prof Muragesh SK1, Santhosha Rao2, “Automated Internet of Things For Underground Drainage and Manhole Monitoring Systems For Metropolitan Cities.” International Journal of Innovative Science, Engineering & Technology, Vol. 2 Issue 4, June 2015.
- [8] Lazarescu, M.T., "Design of a WSN Platform for Long-Term Environmental Monitoring for IoT Applications," Emerging and Selected Topics in Circuits And Systems, IEEE Journal on, vol.3, no.1, pp.45, 54, March 2013.