



IOT-SMART POULTRY FARMING

Ms. B. Akhila Department of Electronics and Communication Engineering, Geethanjali Institute of Science and Technology, Nellore.

Pavuluru Haritha Department of Electronics and Communication Engineering, Geethanjali Institute of Science and Technology, Nellore.

Pandillapalli Abhigna Department of Electronics and Communication Engineering, Geethanjali Institute of Science and Technology, Nellore.

Ponnuru Venkata Sai Deepika Department of Electronics and Communication Engineering, Geethanjali Institute of Science and Technology, Nellore.

Mungara Poornima Department of Electronics and Communication Engineering, Geethanjali Institute of Science and Technology, Nellore.

Pasupuleti Soumya Department of Electronics and Communication Engineering, Geethanjali Institute of Science and Technology, Nellore.

ABSTRACT

This paper introduces an innovative Internet of Things (IoT) solution tailored for poultry farming, integrating edge computing to streamline farm management. The system employs a ESP32 as the central controller, incorporating a Real-Time Clock for precise scheduling through a Bluetooth model. Stepper and Servo motors automate feeding, while relays regulate water supply, significantly minimizing manual intervention and ensuring timely nourishment for hens. Additionally, an IoT weather monitoring system is implemented, featuring a DHT11 sensor to measure temperature, smoke, and humidity. Data is transmitted to a cloud-based server, continuously compared with predefined thresholds, and displayed on an LCD board. In the event of critical conditions, the system triggers alerts and activates a buzzer, providing real-time warnings to nearby farm operators.

Furthermore, an ultrasonic sensor is employed for intruder detection, capturing live images using an ESP-camera. The images are sent to the user's Gmail via an IoT server, along with information from sensors crossing predefined thresholds. This comprehensive approach enhances farm security and management, offering real-time warnings to operators and ensuring proactive responses to environmental and security challenges. The integration of edge computing, ESP32, and diverse sensors contributes to the efficiency, automation, and overall optimization of poultry farming practices.

Keywords:

Smart Poultry Farming, Stepper Motors, Servo Motors, Automated Feeding, Water Supply Regulation, IoT Weather Monitoring, DHT11 Sensor

1.INTRODUCTION

India, historically recognized for its agricultural wealth in terms of abundant food and environmental resources, has faced a gradual decline in prosperity, directly impacting agricultural productivity and the incomes of farmers. Despite being an agrarian economy, the lack of insights into effective agricultural marketing strategies and high-quality production planning has contributed to this regression. One of the noteworthy sectors within agriculture is poultry farming, with chicken emerging as the most favoured produce due to its nutrient-rich composition—high in protein, low in fat and cholesterol, and with lower energy content compared to other poultry varieties. The ease of care and quick propagation of chicken species have further propelled its popularity.

Over the last five years, the chicken production sector has demonstrated promising growth, averaging a yearly increase of 4.63%. This upward trajectory can be attributed to the adoption of standardized farming management practices and adherence to good manufacturing practices. As a result, there has been a notable rise in both domestic consumption and international export of chicken products.



However, despite these positive trends, the poultry farming sector faces challenges that impede its full potential.

One significant obstacle in chicken production lies in the shortage of labour, particularly affecting the export of fresh chicken products. Additionally, there is a prevalent issue of incorrect knowledge sharing and reliance on traditional folk wisdom in chicken farming, adversely impacting the efficiency of operations. Recognizing these challenges, there is a pressing need for innovative solutions that integrate modern technology to optimize processes and enhance overall productivity.

The development of an advanced security alerting system and auto-feeding solution for poultry farms is prompted by the critical need to address existing challenges in the industry. Poultry farms face ongoing threats such as theft, trespassing, and unauthorized access, underscoring the necessity for a sophisticated security alerting system that can provide real-time alerts and proactive responses. Simultaneously, the manual process of feeding poultry presents operational inefficiencies, requiring a robust auto-feeding system for precise control over feeding schedules, promoting the overall health and growth of the birds. The proposed solution must seamlessly integrate with existing farm infrastructure, offering customization options to accommodate diverse farm layouts and security concerns. Real-time monitoring and reporting capabilities are crucial, enabling instant alerts for security breaches and detailed insights into feeding schedules, consumption patterns, and poultry health. Furthermore, the system should be scalable and affordable, ensuring accessibility for poultry farmers of varying scales. The integrated solution aims to revolutionize poultry farming by enhancing security measures, optimizing operational efficiency, and ultimately contributing to the sustainable and efficient production of poultry for the global food supply chain.

2.LITERATURE REVIEW

Glatz and Pym, 2006 [1]. Automation of poultry farms help to reduce the labour cost, increase farm efficiency, improve the productivity, and production rate of meat and egg. Wireless sensors and mobile system network to control and remotely monitor environmental parameters in a poultry farm, the system provides an efficient automated agriculture monitoring system.

K. Sravanth Goud et. Al.2015 [2]. Internet of issue based mostly sensible poultry farm can provides a trouble free and higher observation expertise to the user of the poultry farm. This method can create use of the sensors and microcontroller unit to perform the same operations of feeding, water system and temperature- humidness observation that area unit the most causes for any reasonably epidemic or diseases for poultry birds.

Rupali B. Mahale et. Al.2016 [3]. Use of an intelligent system which used an embedded framework and a wise Phone for monitoring farm to manage environmental parameters using smart devices and technologies.

Geetanjali A. Choukidaret. Al.2017 [4]. Automation of poultry farm by using wireless sensor network and mobile communication provides automated poultry, reduces man power and increases production of healthy chicken.

Raghudathest et al., 2017[5]. "IoT based intelligent poultry management system using linux embedded system".The system proposed by Raghudathesh et al. (2017)monitors and regulates light intensity, temperature, air quality, and humidity. A camera is incorporated for image surveillance on the farm. The system was built around the Arduino Mega board and the Raspberry Pi 3, which acts as a server. Poultry farmers can utilize their mobile devices to access the system from anywhere with internet connectivity. The poultry management system minimizes human intervention since it is capable of regulating the environmental parameters using actuators.

Ayyappan. V et. Al.2017 [6]. Automated system initiates the action automatically to control the environmental parameters such as humidity, temperature, ammonia gas and will decrease the environmental diseases affecting chicken and increase the productivity and eliminate a lot of manpower.

S. Arunkumaret. et. Al. 2018 [7]. The development of an automatic chicken feeding machine can be very useful to the growth of the poultry industry.

Mohammad R. Ahmadi, et. Al.2018 [8]. Wireless sensors and general pocket radio service network system provides an efficient automated poultry farm monitoring system to monitor the healthy atmosphere for chickens in poultry farm without human interference.

3.PROPOSED SYSTEM

In this project we present a working model of IOT-Smart poultry farming. The main objective for implementing this project is to enhance the security alerting system. This delves into the intricacies of building an IoT-enabled poultry farming system, emphasizing the utilization of components such as the ESP-CAM module, ultrasonic sensors, smoke detectors, Real-Time Clock (RTC), DHT11 sensors, Bluetooth, LCD, buzzer, servomotor, relay, and water pump, RPS, Arduino IDE tool, Embedded C language. One of the foundational elements of this system is the ESP-CAM module, which combines an ESP32 microcontroller with a camera, providing a versatile platform for capturing images. The stability and reliability of the system are ensured through the utilization of a regulated power supply, preventing voltage fluctuations that could compromise the performance of sensitive electronic components. The system can be divided into three parts: environmental sensing, load control, and the terminal computer. Environmental sensing includes circuit modules such as those for temperature sensing, The load-control part includes the pump motors, buzzer and automatic feeder. The system transmits the environmental data sensed by the smart poultry to the terminal computer through Wi-Fi, IOT web server is used in the terminal computer to compile these data, and it is then uploaded to Cloud. Finally, the results of the measured poultry environmental parameters are displayed in real time, and a general user can use a smart mobile device to obtain current environmental information about the smart poultry at any time and in any place.

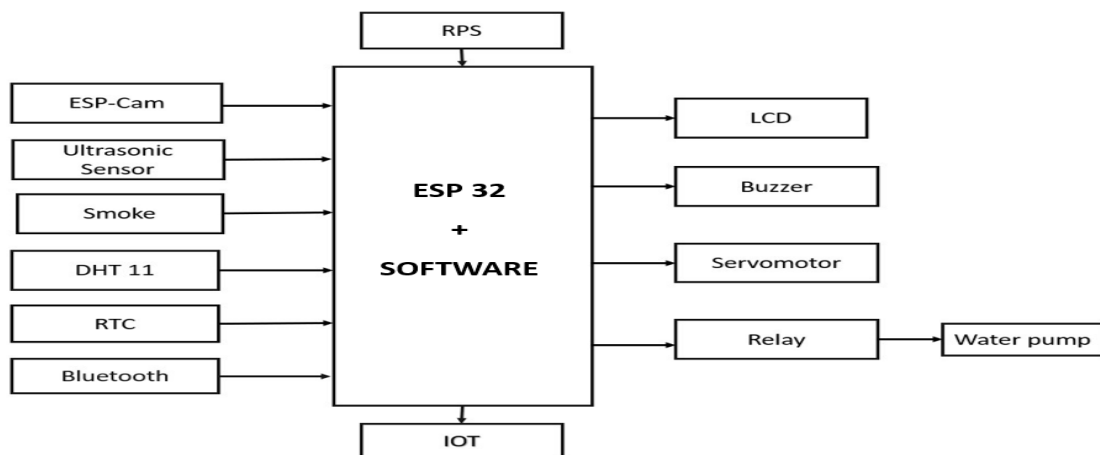

The inclusion of a Real-Time Clock (RTC) module in the IoT poultry farming system is essential for accurate timekeeping. DHT11 sensors, responsible for measuring temperature and humidity, contribute to the overall environmental monitoring of the poultry house. The incorporation of Bluetooth communication in the system introduces a layer of flexibility and interactivity. By allowing a local device to connect to the ESP32, farmers can receive real-time data and exercise control over specific functionalities, enabling farmers to access comprehensive insights into the poultry farming environment from anywhere. The utilization of an LCD (Liquid Crystal Display) in the system serves as a user-friendly interface that provides real-time information about the poultry farm conditions. Displaying sensor readings, system status, and alerts, the LCD becomes a crucial tool for on-site monitoring. For instance, farmers can easily visualize current temperature and humidity levels. The inclusion of a buzzer in the IoT poultry farming system adds an auditory dimension to the alerting mechanism. By providing audible alerts or notifications based on predefined conditions or critical events, the buzzer becomes an invaluable tool for drawing immediate attention to potential issues.



For example, in the event of a sudden temperature spike or smoke detection, the buzzer can emit an alarm, prompting quick intervention. This auditory feedback, coupled with visual displays, creates a multi-sensory approach to monitoring and ensures that farmers are promptly informed of any deviations from optimal conditions. The integration of a servomotor introduces a dynamic element to the poultry farming system. The water pump, another essential component, automates the water supply to the poultry, ensuring a consistent and reliable water source. Connected to the IoT system, the water pump can be activated based on demand, as determined by sensors monitoring water levels in tanks or troughs.

The foundation of smart poultry farming lies in data collection. Poultry farms are equipped with an array of sensors strategically placed to monitor critical parameters such as temperature, humidity, air quality, water consumption, and feed levels. These sensors act as the eyes and ears of the operation, continuously collecting real-time data. The next step is ensuring connectivity; this is achieved through the implementation of Internet of Things (IoT) devices. These devices facilitate the seamless transmission of data from the sensors to a centralized system for further processing. Once the data is collected and transmitted, it is stored in the cloud. Cloud storage provides a scalable and accessible repository for the vast amounts of information generated by the sensors. The integration of cloud technology in smart poultry farming enhances the scalability and accessibility of information, critical for making informed decisions.

Automated systems are a cornerstone of smart poultry farming. Leveraging the insights gained through data analysis, these systems control and automate tasks such as feeding, watering, and climate control. Automated feeders ensure that poultry receives the appropriate amount of nutrition, while water dispensers guarantee a constant supply. By automating these essential tasks, smart farming technologies reduce the need for manual labor and enhance operational efficiency.

Remote management capabilities empower farmers to oversee and control various aspects of the poultry farm from a distance. Mobile applications or web interfaces provide a user-friendly platform for farmers to monitor data, receive alerts, and make adjustments to automated systems. This remote accessibility offers flexibility and convenience, allowing farmers to manage their operations efficiently and respond to emerging situations in real-time.

In smart poultry farming, security alerting buzzers play a crucial role in immediate threat response. Strategically placed around the farm, these buzzers are triggered by surveillance systems, access breaches, or environmental anomalies. Once activated, they emit audible alerts, notifying farm personnel of potential security risks. This swift, real-time notification system allows for prompt action, protecting the well-being of the poultry, farm infrastructure, and sensitive data. Security alerting buzzers contribute to the overall security framework, ensuring a rapid response to emerging threats in the dynamic environment of smart poultry farming.

PROJECT WORKING:

In this system there are five sectors

1. Regulated Power Supply
2. Input Section
 - ESP32-Cam
 - Ultrasonic sensor
 - Smoke sensor
 - DHT11 sensor
 - RTC
3. Output Section
 - LCD
 - Relay
 - Servomotor

- Buzzer
- 4. Microcontroller
- ESP32
- 5. Software

The power is supplied to the RPS module through an adapter. The adapter converts 230v Ac to 12v DC is give to the RPS module. The RPS module (7805) converts the 230 volts ac into 12v of dc to 5v dc. The 5v of power supply goes to all components in the system. Capacitors are used to reduce the noise, When the power supply is passed the LED will blow and system work will start. The input of the first module is ESP32-Camera which capture the images and given to the controller then the controller will send the images to the mail. The input of the second module is sensors they are Ultrasonic sensor (HCSR04) which can detect the intruder, DHT11 sensor which can detect the temperature & Humidity, Smoke sensor which can detect the smoke/Pollution, when the threshold level of these sensors exceeds automatically the buzzer is activated and ESP-cam will capture the images and given to the controller, the controller will send the images immediately to the mail. The another input module is Real time clock (RTC) which is used to set the timings of supplying food and water automatically through Bluetooth module.

The output module is servomotor is for feeder which is used for angle rotation and another output module is relay for water supply. Buzzer for alerting purpose. All the input and output modules are connected to the ESP32 microcontroller which controls the data.

In the ESP32 microcontroller contains the software programming code Embedded C. The ESP32 microcontroller can be used to control the all process in the system. The 16x2 LCD will display the output. so this system can providing the sensor based surveillance and image capturing and mail alerts and automated feeding & providing security factors for the system is working of the project.

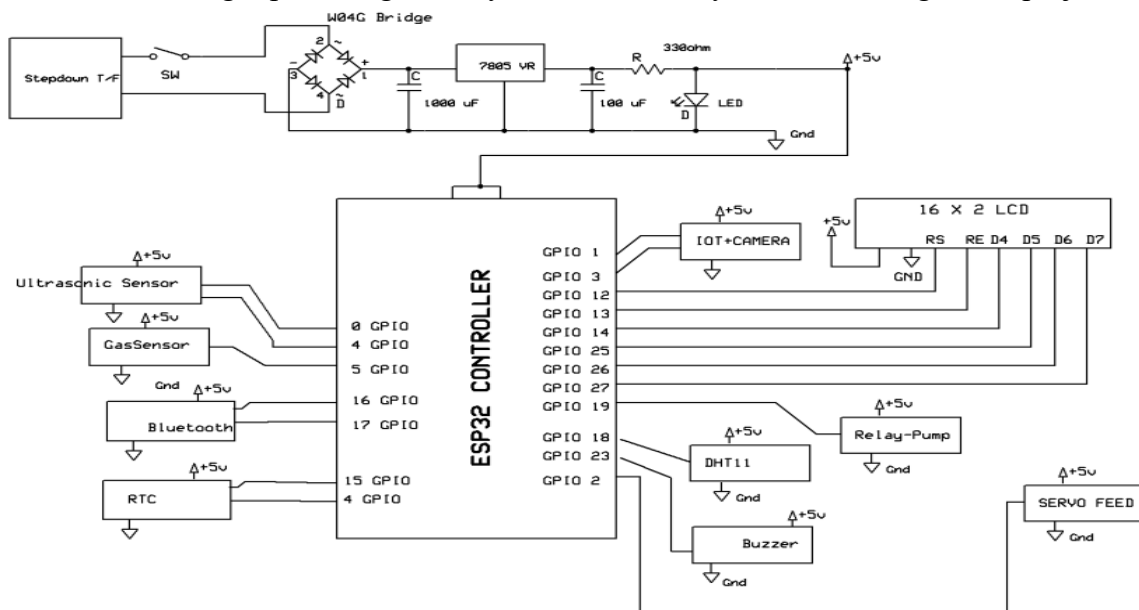

In poultry farm, it is use to feed the food in container, maintain the temperature using water sprinkler. We have used Temperature, humidity, intruder detection IR and RTC (Real Time Clock). In this we using IOT module to set time customization for feeding and providing water. This system will control temperature, humidity, Intruder detection without any human interface. Based on the threshold values it will switch on the devices. Thus this system design provides automated poultry, reduces man power and increases production of healthy chicken. Every sensor parameters data will display on LCD and IOT database.

The inclusion of a Real-Time Clock (RTC) module in the IoT poultry farming system is essential for accurate timekeeping. DHT11 sensors, responsible for measuring temperature and



humidity, contribute to the overall environmental monitoring of the poultry house. The incorporation of Bluetooth communication in the system introduces a layer of flexibility and interactivity. By allowing a local device to connect to the ESP32, farmers can receive real-time data and exercise control over specific functionalities, enabling farmers to access comprehensive insights into the poultry farming environment from anywhere. The utilization of an LCD (Liquid Crystal Display) in the system serves as a user-friendly interface that provides real-time information about the poultry farm conditions. Displaying sensor readings, system status, and alerts, the LCD becomes a crucial tool for on-site monitoring. For instance, farmers can easily visualize current temperature and humidity levels. The inclusion of a buzzer in the IoT poultry farming system adds an auditory dimension to the alerting mechanism. By providing audible alerts or notifications based on predefined conditions or critical events, the buzzer becomes an invaluable tool for drawing immediate attention to potential issues.

For example, in the event of a sudden temperature spike or smoke detection, the buzzer can emit an alarm, prompting quick intervention. This auditory feedback, coupled with visual displays, creates a multi-sensory approach to monitoring and ensures that farmers are promptly informed of any deviations from optimal conditions. The integration of a servomotor introduces a dynamic element to the poultry farming system. The water pump, another essential component, automates the water supply to the poultry, ensuring a consistent and reliable water source. Connected to the IoT system, the water pump can be activated based on demand, as determined by sensors monitoring water levels in tanks or troughs.

The foundation of smart poultry farming lies in data collection. Poultry farms are equipped with an array of sensors strategically placed to monitor critical parameters such as temperature, humidity, air quality, water consumption, and feed levels. These sensors act as the eyes and ears of the operation, continuously collecting real-time data. The next step is ensuring connectivity; this is achieved through the implementation of Internet of Things (IoT) devices. These devices facilitate the seamless transmission of data from the sensors to a centralized system for further processing. Once the data is collected and transmitted, it is stored in the cloud. Cloud storage provides a scalable and accessible repository for the vast amounts of information generated by the sensors. The integration of cloud technology in smart poultry farming enhances the scalability and accessibility of information, critical for making informed decisions.

Automated systems are a cornerstone of smart poultry farming. Leveraging the insights gained through data analysis, these systems control and automate tasks such as feeding, watering, and climate control. Automated feeders ensure that poultry receives the appropriate amount of nutrition, while water dispensers guarantee a constant supply. By automating these essential tasks, smart farming technologies reduce the need for manual labor and enhance operational efficiency.

Remote management capabilities empower farmers to oversee and control various aspects of the poultry farm from a distance. Mobile applications or web interfaces provide a user-friendly platform for farmers to monitor data, receive alerts, and make adjustments to automated systems. This remote accessibility offers flexibility and convenience, allowing farmers to manage their operations efficiently and respond to emerging situations in real-time.

In smart poultry farming, security alerting buzzers play a crucial role in immediate threat response. Strategically placed around the farm, these buzzers are triggered by surveillance systems, access breaches, or environmental anomalies. Once activated, they emit audible alerts, notifying farm personnel of potential security risks. This swift, real-time notification system allows for prompt action, protecting the well-being of the poultry, farm infrastructure, and sensitive data. Security alerting buzzers contribute to the overall security framework, ensuring a rapid response to emerging threats in the dynamic environment of smart poultry farming.

ADVANTAGES

Implementing an advanced security alerting system and auto-feeding solution for poultry farms offers several advantages that contribute to the overall efficiency, safety, and productivity of the operation:



- 1. Enhanced Security Measures:** The system provides real-time alerts and proactive responses to security threats, reducing the risk of theft, trespassing, and unauthorized access. This heightened security contributes to the overall safety and well-being of the poultry, protecting farm assets and preventing economic losses.
- 2. Operational Efficiency and Labour Savings:** Automation of the feeding process optimizes operational efficiency by providing precise control over feeding schedules. This not only ensures that the poultry receives timely and accurate nutrition but also reduces the manual labour required for feeding, allowing farm operators to focus on other critical aspects of poultry management.
- 3. Improved Poultry Health and Growth:** The auto-feeding system ensures consistent and controlled nutrition, promoting the overall health and growth of the poultry. This leads to better-quality poultry products and can positively impact the economic returns for the farm.
- 4. Real-Time Monitoring and Decision-Making:** The ability to monitor security alerts, feeding schedules, and consumption patterns in real-time empowers farm operators to make informed decisions promptly. This proactive approach helps prevent potential issues before they escalate, contributing to the overall health and productivity of the poultry.
- 5. Customization and Adaptability:** The system's flexibility allows for customization to meet the specific needs of different poultry farms, considering factors such as farm size, layout, and unique security concerns. This adaptability ensures that the solution can cater to a wide range of operations within the poultry industry.
- 6. Scalability for Future Growth:** The integrated solution is designed to be scalable, accommodating the growth of poultry farms over time. This scalability ensures that the system remains effective as the farm expands, providing a sustainable solution for long-term industry development.
- 7. Cost-Effective Security Measures:** By addressing security concerns through an automated alerting system, the solution offers a cost-effective alternative to traditional security measures. This is especially valuable for smaller-scale poultry farms that may have limited resources but still require robust security measures.
- 8. Contribution to Industry Sustainability:** The improved efficiency and productivity facilitated by the system contribute to the overall sustainability of the poultry industry. By optimizing resource utilization, reducing waste, and enhancing security, the system supports environmentally and economically sustainable poultry farming practices.

In summary, the implementation of an advanced security alerting system and auto-feeding solution in poultry farming not only mitigates security risks but also significantly improves operational processes, leading to healthier poultry, reduced labor requirements, and enhanced overall sustainability of the industry.

APPLICATIONS

1. Poultry Farms:

- **Security Enhancement:** Protecting poultry farms from theft, trespassing, and unauthorized access through real-time security alerts and access control.
- **Operational Efficiency:** Optimizing feeding schedules and reducing manual labor with an automated feeding system for enhanced poultry health and growth.

2. Small-Scale Poultry Operations:

- **Cost-Effective Security:** Providing cost-effective security measures for smaller poultry farms with limited resources.
- **Labor Savings:** Minimizing labor requirements through automated feeding, making poultry farming more manageable for smaller-scale operations.

3. Integrated Farm Management:

- **Holistic Monitoring:** Offering a centralized platform for real-time monitoring of security alerts, feeding schedules, and consumption patterns.

- **Data-Driven Decision Making:** Empowering farm operators with data analytics to make informed decisions for improved overall management.
- 4. **Research and Development:**
 - **Data Collection:** Providing valuable data on poultry behavior, feeding patterns, and security incidents for research and development purposes.
 - **Customization for Studies:** Facilitating customization options to adapt the system for specific research studies related to poultry farming.
- 5. **Educational Institutions and Training Centers:**
 - **Learning Tool:** Serving as an educational tool for agricultural students and professionals to understand modern poultry farm management practices.
 - **Hands-On Training:** Offering hands-on training opportunities with a comprehensive system that mirrors real-world farm management scenarios.
- 6. **Government and Regulatory Bodies:**
 - **Compliance Monitoring:** Facilitating compliance monitoring with security measures, ensuring adherence to regulations and standards in the poultry industry.
 - **Data Reporting:** Providing detailed reports on security incidents, feeding schedules, and poultry health for regulatory purposes.
- 7. **Technology Providers and Integrators:**
 - **Solution Integration:** Collaborating with technology providers to integrate the system with other agricultural technologies and farm management software.
 - **Customization for Clients:** Offering customizable solutions for clients with specific needs or requirements in the agricultural sector.
- 8. **Sustainable Farming Initiatives:**
 - **Resource Optimization:** Contributing to sustainable farming practices by optimizing resource utilization, reducing waste, and improving overall efficiency.
 - **Environmental Impact:** Monitoring and controlling the environmental impact of poultry farming through efficient feeding practices.

4.RESULTS

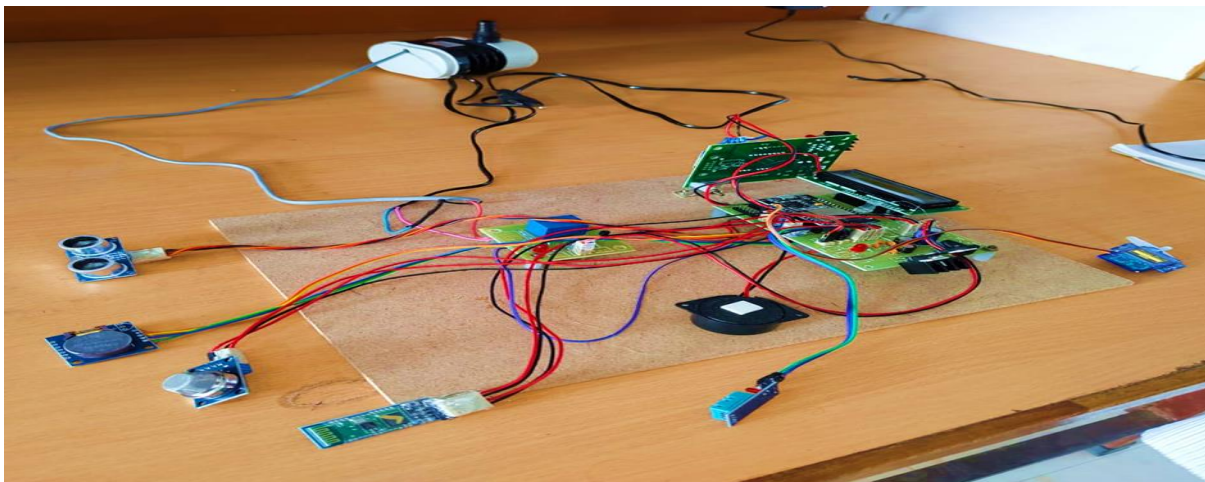

The above image shows the hardware equipment of the project. The kit is turned ON by giving the regulated power supply of 12v which is then converted to 5v dc current. The LED is the indication for 5v current so, if there is 5v current then automatically the LED glows. The generated 5v dc current passes to every hardware component in the circuit.



When we hit the reset button after providing the regulated power supply, the LCD displayed the IOT Poultry System. The output is seen as the following image, later we have connected the IoT module via a WIFI connect

The terms like date, day along with the time is displayed on LCD display.

We need to set timings according to the time displayed only.

The values of ultrasonic sensor range (U), gas sensor value(G), temperature value(T), humidity value(H) values are displayed on the LCD display.

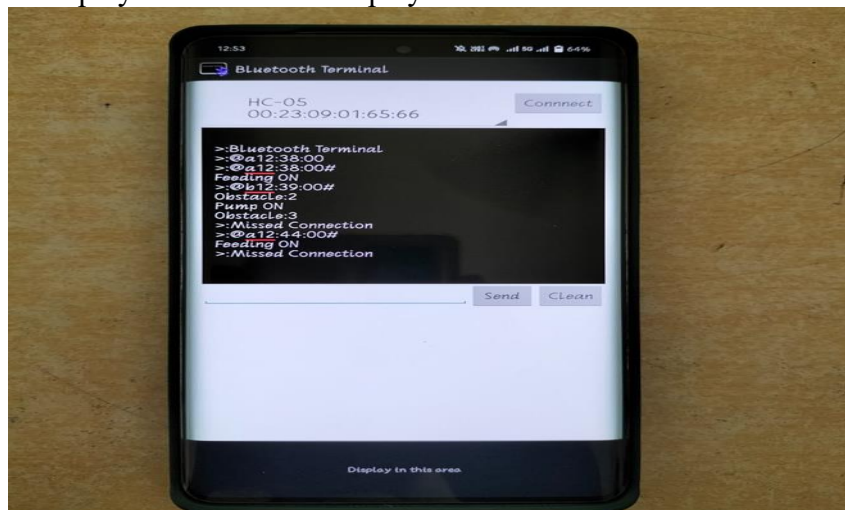

To set the timings for feeding and the water supply, we have set the time through Bluetooth Terminal with two commands

- 1) @a12:38:00#
- 2) @b12:44:00#

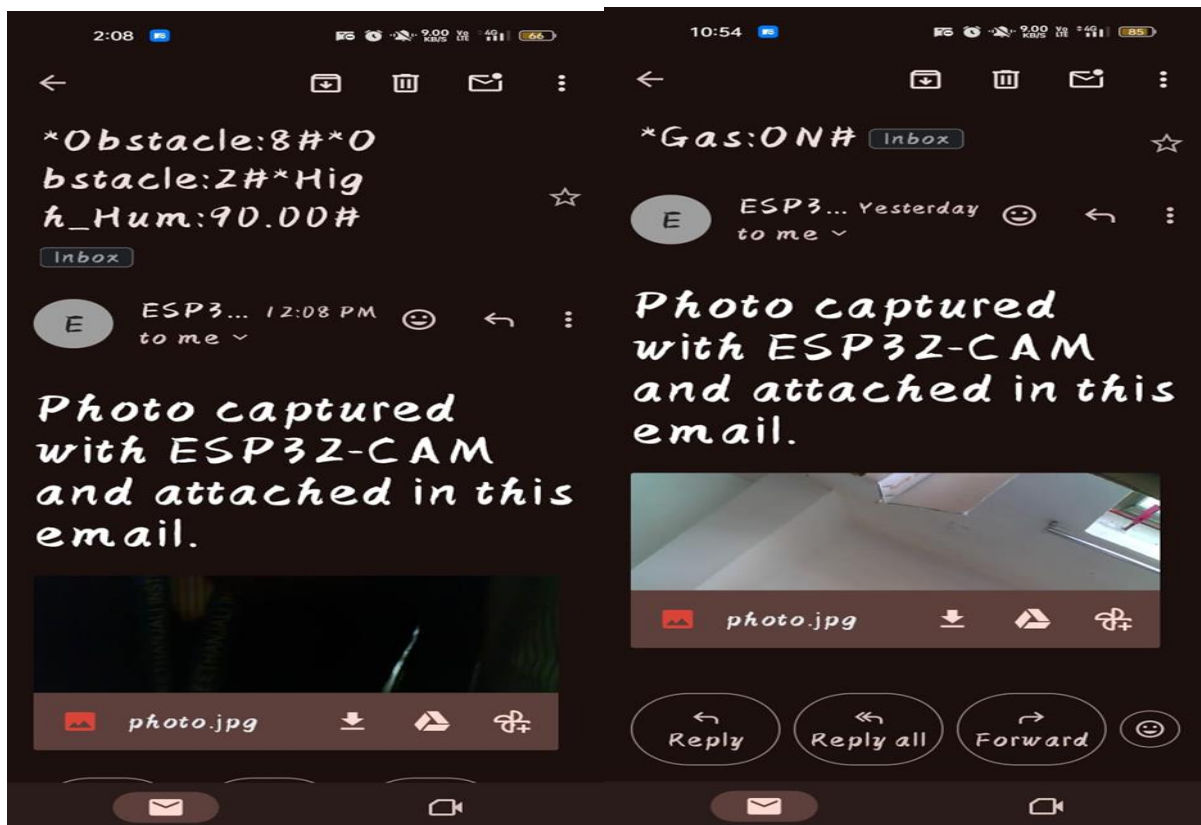

Fig a: email sent when obstacle identified

fig b: email sent when gas identified

When the threshold limits are exceeded, the buzzer is on and the emails are sent along with the message and the attachment of photo.

5.CONCLUSION

In conclusion, the advent of IoT-enabled smart poultry farming marks a transformative shift in the agricultural landscape, offering numerous benefits for farmers and poultry alike. By integrating advanced technologies such as edge computing, sensor networks, this innovative approach revolutionizes farm management practices. Through the seamless automation of tasks like feeding, watering, and environmental monitoring, IoT smart poultry farming significantly reduces manual labour while ensuring optimal conditions for poultry health and productivity.

Moreover, the enhanced security features, including intruder detection and remote monitoring capabilities, farm security and protect against potential threats. With alerts and notifications sent directly to farmers' devices, proactive responses to emergencies are facilitated, mitigating risks and safeguarding farm assets. Overall, IoT smart poultry farming represents a paradigm shift towards more sustainable, efficient, and secure agricultural practices. By harnessing the power of technology, farmers can optimize production, minimize risks, and ensure the well-being of their poultry, paving the way for a brighter and more prosperous future in poultry farming.

REFERENCES:

- [1] **Glatz, P. & Pym, R. (2006)**. Poultry housing and management in developing countries. In poultry development review of food and Agricultural organization of United
- [2] **K. Sravanth Goud & Abraham Sudharson (2015)**. Internet based Smart Poultry Farm. Indian Journal of Science and Technology, Vol 8 (19), pp 1-5.
- [3] **Rupali B. Mahale & S. S. Sonavane (2016)**. Smart Poultry Farm Monitoring Using IOT and Wireless Sensor Networks. International Journal of Advanced Research in Computer Science, Vol. 7, No. 3, pp 187-190.



- [4] **Geethanjali A. Choukidar & N. A. Dawande (2017)**. A Survey on Smart Poultry Farm Automation and Monitoring System. *Int. J. of Innovative Res. in Sci., Eng. and Tech.*, Vol. 6, Issue 3, pp 4806-4810
- [5] **S. Arunkumar & N. Mohana Sundaram (2018)**. Smart Poultry Farming. *International Journal of Innovative Technology and Exploring Engineering*, Vol. 8 Issue 2S2. Pp 289-291.
- [6] **Mohammad R. Ahmadi, Naseer Ali Hussien, Ghassan F. Smaisim , & Naser M Falai (2018)**. A Survey of Smart Control System for Poultry Farm Techniques. *Int. Conf. Distributed Computing and High Performance Computing*, 25-27, Nov. 2018.
- [7] **Eric Hitimana Gaurav Bajpai, Richard Musabe & Louis Sibomana (2018)**. Remote Monitoring and Control of Poultry Farm using IoT Techniques. *Int. J. of Latest Tech. in Eng., Management & Applied Science*, Vol. VII, Issue V, pp 87-90.
- [8] **Ramgirwar S. S. & Dawande N. A. (2018)**. FPGA based smart poultry farm management system. *Int. J. of Adv. Res. In Sci. and Tech.* Voi. 07, Issue 05, pp 265-271.
- [9] S. V. G. Kumar, M. Vadivel, U. Penchalaiah, P. Ganesan and T. Somassoundaram, "Real Time Embedded System for Automobile Automation," 2019 IEEE International Conference on System, Computation, Automation and Networking (ICSCAN), Pondicherry, India, 2019, pp. 1-6, doi: 10.1109/ICSCAN.2019.8878820.