



EV CHARGING STATIONS MANAGEMENT SYSTEM

Dr. Vilas Gaikwad, Head of Dept. of information technology,
Trinity college of engineering & research pune.

Mr.Sahildeshmukh ,Mr.HrutuDeshmukh , Mr.HarshalBadgular , Ms.RajshreeRokade, Student
of Trinity college of engineering & research pune.

ABSTRACT

Automakers like Tata and Tesla have just launched new electric cars into the market. Several of the stations are also equipped to charge these vehicles. However, given the state of affairs, it takes these cars anywhere from fifteen to thirty minutes to fully charge. Other patrons may have to wait a considerable amount of time if the station is packed and every slot has been taken. Our objective is to develop a system that will deal with issues of this nature. We are developing a system that will connect all of the electric vehicle charging stations. Those who wish to drive long distances in their electric vehicles will find our method handy as it allows them to find the station of their choosing while saving time. It will be quite simple to use. Your reservation will be made for the specified time period if it is available. If not, you will be prompted by the system to submit your updated schedule. Users using this option must pay a percentage of the total amount online in order to finalize their reservation. Additionally, our system will show the shortest map route to the specified station. Furthermore, using an interface that our system will provide, charging stations will be able to view all available slots, booked slot lists, and control slot scheduling. Our plan is to create this solution specifically for Android-powered gadgets. We will use Google Maps API for direction sensing and time-slot allocation approaches to construct this system. Voice instructions will be used by our chatbot system to control software. With the help of an online payment gateway, a user may quickly make payments. By using the system, people can quickly and easily see and reserve the correct station, saving a ton of time.

Keywords: Smart management, charging slot, EV Cars, Map

I. INTRODUCTION

In recent years, global warming and the depletion of fossil fuels due to mass consumption of energy resource has become an increasingly recognized world problem. To control these problems, the installation of renewable energy systems, which do not depend on fossil fuels, is an effective countermeasure. In Japan, since the government has introduced Feed-in tariffs (Fit), the introduction of photovoltaic systems has been expanded rapidly. However, the output power from increased number of photovoltaic systems is extremely large and tends to have a bad effect on the system frequency and distribution voltage. To address this problem, the Japanese government has begun reconsidering the Fit system. The fact that PV installation is becoming less expensive every year exacerbates this issue. Consequently, a significant drop in the cost of PV electricity is anticipated in the future. In this study, EV charging stations that near-exclusively purchases power from PV systems on smart houses and sells power to electric vehicles (EV) and smart houses is proposed as an aggregator. The EV charging station has the need to utilize a fixed battery for electricity trading.

II. RELATED WORK

This research [1] suggests using a coreless axial flux permanent magnet machine as the propulsion engine because of its low stator mass, small core loss, and almost nil cogging torque. The propulsion motor is powered by a three-phase inverter that receives its dc bus feed from a three-port DC/DC converter. The converter accepts inputs from a solar panel and batteries. The threeport converter uses



gallium nitride (GaN) devices, which enable very high switching frequencies and reduce the size of the transformer that provides galvanic isolation between the two sources and the output. Depending on operational circumstances, the three-port converter permits bi-directional power transfer between the propulsion engine and battery in addition to ensuring that the solar panel operates at its maximum power point. Working with a novel method of current weakening enables a wide range of speeds, which is necessary for the solar racing car application. Using this technique, the motor side inverter's dc bus voltage is increased at speeds higher than the rated. As small-sized [2] superconducting magnetic energy storage (SMES) system is commercially available at present, the function and effect of a small-sized SMES in an EV charging station including photovoltaic (PV) generation system is studied in this paper, which provides a practical application of small-sized SMES. To shed light on SMES's characteristics, a comparison of three rapid reaction energy storage systems—flywheel, capacitor (super-capacitor), and SMES—is also provided. A common dc bus is used to connect the PV generating system, EV battery, and SMES, each with their own converters. To connect to the grid, a voltage source converter (VSC) is utilized. SMES is used with its fast power response feature to keep the dc bus stable. An energy management strategy is intended to regulate the energy transfer between PV units, SMES, EV batteries, and the power grid during the course of an EV charging station's long-term operation. To confirm the functionality and performance of SMES, simulation tests are conducted on the EV charging station system model created in MATLAB/SIMULINK. Having a network [3] of fast charging stations seems necessary in order to make EVs more attractive and to achieve larger uptake of them. Commercially available rapid chargers with a 50 kW capacity can charge an average electric vehicle (EV) in around one hour. Nonetheless, guidelines now include a 240 kW fast charging level that can fully charge an average EV in 10 minutes. It is anticipated that these high power rapid chargers would become accessible soon. Multi-megawatt levels of charging power are required from a charging station when several EVs are being quickly charged at once. Here, charging station architecture is essential for supporting expansion in the future and for offering rapid charging at the lowest possible cost, with the least amount of grid impact and maximum service quality. A topological survey of charging stations found in the literature is presented in this research. A range of charging station configurations are showcased, contrasted, and assessed according to grid support, power density, modularity and other factors. Electric vehicles (EVs) [4] are being introduced by different manufacturers as an environment-friendly alternative to vehicles with internal combustion engines, with several benefits. The number of EVs is expected to grow rapidly in the coming years. However, uncoordinated charging of these vehicles can put a severe stress on the power grid. The problem of charge scheduling of EVs is an important and challenging problem and has seen significant research activity in the last few years. This review covers the recent works done in the area of scheduling algorithms for charging EVs in smart grid. The works are first classified into two broad classes of unidirectional versus bidirectional charging, and then, each class is further classified based on whether the scheduling is centralized or distributed and whether any mobility aspects are considered or not. It then reviews the key results in this field following the classification proposed. Some interesting research challenges that can be addressed are also identified. In order to interface one PV port [5], one bidirectional battery port and one load port of PV-Battery DC power system, a novel non-isolated three-port DC/DC converter named Boost Bidirectional Buck Converter (B3C) and its control method based on three domain control are proposed in this paper. The power flow and operating principles of the proposed B3C are analyzed in detail, and then the DC voltage relation between three ports is deduced. The proposed converter features high integration and single-stage power conversion from both photovoltaic (PV) and battery ports to the load port, thus leading to high efficiency. The current of all the three port is continuous, so the electromagnetic noise can be reduced. Furthermore, the control and modulation method for B3C has been proposed for realizing Maximum Power Point Tracking (MPPT), battery

management and bus voltage regulation simultaneously. The operation can be transited between conductance mode and MPPT mode automatically according to the load power. Finally, experimental verifications are given to illustrate the feasibility and effectiveness of the proposed topology and control method.

III. OPEN ISSUES

A lot of work has been done in this field thanks to its extensive use and applications. This section mentions some of the approaches that have been implemented to achieve the same purpose. These works are mainly differentiated from the techniques for smart management of EV charging station systems.

IV. PROPOSED SYSTEM

We propose a Smart EV Charging station System where we used slot booking system to book EV vehicle charging station to charge vehicles. We further categories this slots according to charging socket type. We have also used AI voice assistant to communicate user with system via vocal commands. We also used GMAPS API to show shortest route to reach at destination. The system uses NLP for AI voice assistance as well as MySQL databases for storing a system logs as well as slot management.

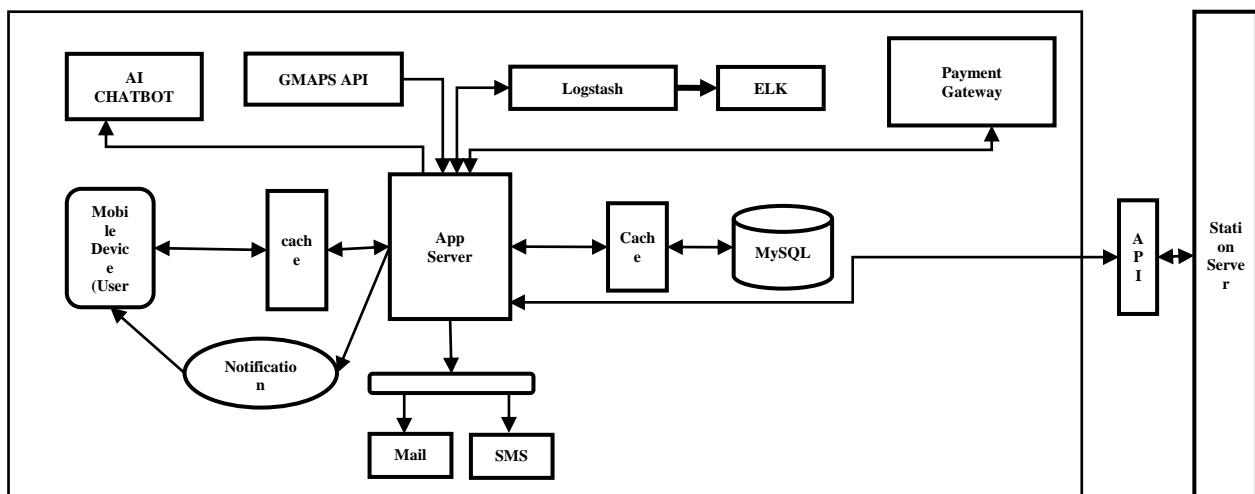

Fig 1 Booking System Architecture

V. CONCLUSION

Through this study project, we have gained knowledge on efficient reservation handling and charging station scheduling. The creation of Virtual Personal Assistants (VPAs) was taught to us. By adapting the combination node method to the dynamic location utilized in general, such as mobile phones for online transportation, this research has given rise to the concept of shortest route search system. In addition to that, we learned how to integrate payment gateways into systems.

REFERENCES

1.V. Rallabandi D. Lawhorn J. He and D. M. Ionel "Current weakening control of coreless afpm motor drives for solar race cars with a three-port bi-directional dc/dc converter" 2017 IEEE 6th International Conference on Renewable Energy Research and Applications (ICRERA) pp. 739-744 Nov 2017.



2. Y. Liu Y. Tang J. Shi X. Shi J. Deng and K. Gong "Application of small-sized smes in an ev charging station with dc bus and pv system" IEEE Trans. on Applied Superconductivity vol. 25 no. 3 pp. 1-6 June 2015.
3. M. Ahmadi N. Mithulanathan and R. Sharma "A review on topologies for fast charging stations for electric vehicles" 2016 IEEE International Conference on Power System Technology (POWERCON) pp. 1-6 Sep. 2016.
4. J. C. Mukherjee and A. Gupta "A review of charge scheduling of electric vehicles in smart grid" IEEE Systems Journal vol. 9 no. 4 pp. 1541-1553 Dec 2015.
5. H. Zhu D. Zhang B. Zhang and Z. Zhou "A nonisolated three-port dcdc converter and three-domain control method for pv-battery power systems" IEEE Trans. on Industrial Electronics vol. 62 no. 8 pp. 4937-4947 Aug 2015.
6. A. Hassoune M. Khafallah A. Mesbahi and T. Bouragba "Smart topology of evs in a pv-grid system based charging station" 2017 International Conference on Electrical and Information Technologies (ICEIT) pp. 1-6 Nov 2017.
7. B. Honarjoo S. M. Madani M. Niroomand and E. Adib "Non-isolated high step-up three-port converter with single magnetic element for photovoltaic systems" IET Power Electronics vol. 11 no. 13 pp. 2151-2160 2018.
8. S. Bai D. Yu and S. Lukic "Optimum design of an ev/phev charging station with dc bus and storage system" 2010 IEEE Energy Conversion Congress and Exposition pp. 1178-1184 Sep. 2010.
9. H. Zhu D. Zhang B. Zhang and Z. Zhou "A nonisolated three-port dcdc converter and three-domain control method for pv-battery power systems" IEEE Trans. on Industrial Electronics vol. 62 no. 8 pp. 4937-4947 Aug 2015.
10. H. Zhu D. Zhang Q. Liu and Z. Zhou "Three-port dc/dc converter with all ports current ripple cancellation using integrated magnetic technique" IEEE Trans. on Power Electronics vol. 31 no. 3 pp. 2174-2186 March 2016.
11. SunTech Power STP235-20-Wd [online] Available: <https://www.freecleansolar.com/235W-solar-panels-Suntech-STP235S-20-Wd-mono-p/stp235s-20-wd.htm>.
12. CREE C3M0065090D MOSFET [online] Available: <https://www.wolfspeed.com/c3m0065090d>.
13. Infineon IPW90R120C3 MOSFET [online] Available: https://www.infineon.com/dgdl/Infineon-IPW90R120C3-DS-v01_00-en.pdf?fileId=db3a3043183a955501185000eld254f2