



## “EXPERIMENTAL AND FEA INVESTIGATION OF V SHAPE SUSPENSION SPRING WITH MATERIALS UNDER LOADING CONDITIONS”

**Pavan Subhash Baravkar** PhD Sholar Sandip University Trambakeshwar Rd, Nashik, Maharashtra  
422213 :pavanbaravkar49@gmail.com

**Dr Amol D Lokhande** Professor, Sandip University, Trambakeshwar Rd, Nashik, Maharashtra  
422213 : amol.lokhande@sandipuniversity.edu.in

### ABSTRACT

This study reviews the initial development of the suspension system, the need for automotive system suspension, the concept of vibration, its causes, causes and effects of vibration in the automotive system. These updates include important information about advanced vehicle parking systems, standard and standard parking systems. The suspension system also helps absorb bumps on the road and provides a safe and comfortable ride. The leaf spring is a simple spring type, often used for suspension in wheeled vehicles. Leaf Springs long and small plates are attached to the frame of the trailer that sits above or below the trailer axis. There are springs of mono leaves, or single-leaf springs, that cover just one plate of spring metal. These are usually dense in the middle and come out at the end, and do not provide too much power and suspension for towing vehicles. Leaf spring is widely used in heavy vehicles such as tractor's trolley, buses, freight trucks. For the purpose of increasing strength, strength, elasticity, we use V-Strip suspension spring instead of leaf spring. The V-Strip suspension spring, which we review, is a specially designed leaf spring used for Tractor Trolley.

**Keywords:** Suspension System, , FEA, Modern Type Of Suspension, , V Shape Spring. Composite Material, , E-Glass/ Epoxy, Re-Manufacturing, Effort Factors, CSFS, Critical Factors.

### I. INTRODUCTION

The modern car has been around since the days when “just walking” was enough to satisfy the car owner. Improvements in suspension, increased strength and durability of parts, and improvements in tire design and construction have played a major role in talking about the comfort and safety of driving. Basically, suspension means the use of front and rear springs to stabilize the car's frame, body, engine and power train over wheels. These relatively complex assemblies make up what is known as the Sprung weight. Non-slip weight, on the other hand, includes wheels and wheels, break assemblies and other structural elements that are not supported by springs. The springs used in modern cars and trucks are made of a variety of shapes, shapes, sizes, prices and strengths. Types include leaf springs, coil springs, wind springs and torsion bars. These are used in four sets per car, or paired with various combinations and attached to the car with many different mounting techniques. The car frame and body are attached to the front and rear not directly but through springs and shock absorbers. The combination of parts, which makes the separation of the parts from the roadmap, may be in the form of a jump, pitch and roll is called a suspension system. The car's suspension system separates the tire and the car's integrated axis from its body. The main function of the suspension system is to separate the body of the vehicle from shock and vibration produced due to road instability. Cars are provided with shock absorbers for this purpose. It is in a state of spring and humidity. The suspension system is provided both at the end and back of the vehicle. The suspension system also maintains the vehicle's stability in turning or rolling when the vehicle is moving. The ability to try new designs or ideas on a computer gives you the opportunity to eliminate problems before you start producing. Additionally, designers can quickly and easily determine the sensitivity of certain molding parameters to the quality and production of the final component. The main leaf spring and V-shape spring strip were created with modeling software such as Pro-E and imported into the ANSYS 15 analysis software, loading, boundary conditions are provided for the imported model and the result is tested by the post processor. Different comparative results of the main steel spring and the V-strip suspension spring are available to predict the benefits of the V-Strip Suspension spring to load the continuous level of a small tractor's trolley used on the farm to carry quality imported fruit.

### Analytical Design of Composite V- spring

The V shape strip springs, which consist of a straight strip of composite E-Glass / Epoxy material, bend in V form. As design point of view it is considered as the double cantilever spring because it is assumed that the spring is fixed at the clamp.

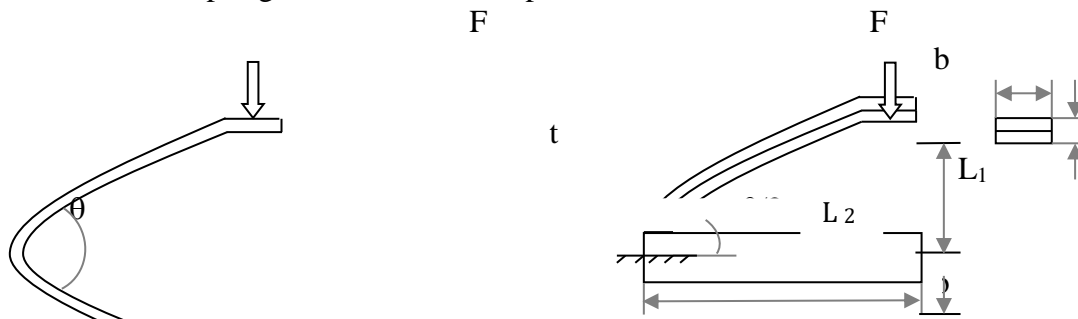

Figure 1.1: Graphical representation of V-spring

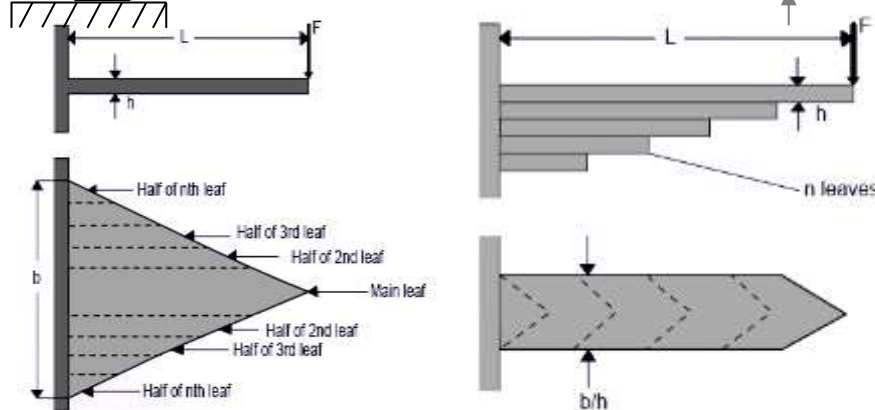

Figure 1.2: V-spring representation as triangular plate

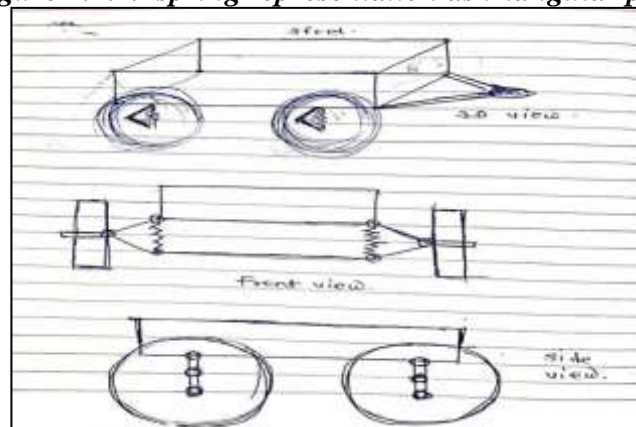

Fig 1.3: Concept of V-Strip Suspension Spring

## II. LITERATURE REVIEW

### FEM Comparison and Leaf Fountains Improved Suspension with Performance Component

Finite Element analysis tools offer the great advantage of allowing design teams to consider almost any design option without incurring the costs associated with production and machine time. The ability to try new designs or ideas on a computer gives you the opportunity to eliminate problems before you start producing. Additionally, designers can quickly and easily determine the sensitivity of certain molding parameters to the quality and production of the final component. The main leaf model of the leaf and the V-shaped V-line were created with modeling software such as Pro-E and imported into ANSYS12 analysis software, uploads, border conditions are provided for the imported model and the



result is tested by post processor. Different comparative results of spring steel and V-shape strip spring are available to predict the benefits of V-shape strip spring continuous loading of small trailer used on the farm to bear fruit for export quality.

**✚Design And Analysis Of Leaf Spring In A Heavy Truck GODATHA JOSHUA JACOB, Mr. M.DEEPAK**

The leaf spring is a simple spring type, often used for suspension in wheeled vehicles. Leaf Springs plates long and small are attached to the frame of the trailer that sits above or below the trailer axis. There are monoleaf springs, or single leaf springs, that cover one plate of spring metal. These tend to squeeze in and out at the end, and do not provide much power and suspension for towing vehicles. Drivers who want to pull heavy loads often have to use springs, which include several springs of varying lengths mounted on top of one another. When the leaf leaf is short, it will be close to the ground, giving the same semielliptical shape the spring of one leaf becomes larger in the middle. The springs will fail due to fatigue caused by repeated spring fluctuations. The aim of the project is to design and model the leaf spring according to the loads used. The materials currently used in the spring of the leaves are stainless steel. In this project we will design a leaf spring for Mild Steel building materials and Glass Carbon compositions by changing the reinforcement angle. We will explore power differences as we change the reinforcement angle. To validate this design we have done a FeA Building Analysis performed on the spring leaf using two different Mild Steel and Glass Carbon materials. Modal and Fatiuge analysis is also ongoing. Pro / Engineer software is used for modeling and ANSYS is used for analysis.

**✚Read and Update on Leaf Spring analysis PULKIT SOLANKI1 , DR. AJAY KUMAR KAVITI2**

We know that the spring plays very essential part of every automobile for suspension point of view. Leaf spring is the main type of suspension system which is used in many light and heavy vehicles. Leaf spring used in many vehicles due to having some main characteristics which are shown below.

- 1) Uniformly load distribution
- 2) Lower cost
- 3) Rough used
- 4) Easier in Isolation

And tightly attached with working frame Today every automobile company has been working on increasing the efficiency with reducing the weight without having any load carrying capacity. In this paper we would like to review some previous research work performed on the leaf spring by previous researchers for increasing the working condition and capacity with load reduction. The paper based on material composition, experimental testing and load (Steady, Dynamic) study etc.

**III. METHEDODOLOGY**

**Materials for V-strip suspension spring :**

Plain carbon steel, Chromium vanadium steel, Chromium-Nickel-Molybdenum steel, silicon manganese steel, common materials used in the construction of leaf springs. Items selected for V-strip suspension are 65Si7. The design parameters selected for the V-strip suspension are listed in the table.

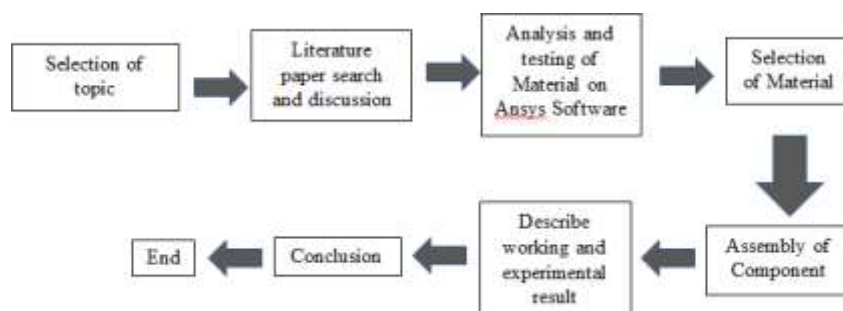

**Fig 2: Material for V-Strip Suspension Spring**

Design Parameters	Values
Material selected	Stainless steel
Tensile Strength	440 N/mm <sup>2</sup>
Field Strength	250 Mpa
Young's modulus	210 Gpa
Length(before bending)	290 mm
Length (after bending)	145 mm
Width	30 mm
Thickness	4 mm
Angle between v-carrying due to spring	Around 40 °
Load Carrying Capacity	150 kg
Number Of Strips	4

### A. FEA PROCEDURE

FEA tool is the mathematical idealization of real system. Is a computer based method that breaks geometry into element and link a series of equation to each, which are then solved simultaneously to evaluate the behavior of the entire system. It is useful for problem with complicated geometry, loading, and material properties where exact analytical solution are difficult to obtain. Most often used for structural, thermal, fluid analysis, but widely applicable for other type of analysis and simulation.[6] Figure 1 shows procedure of FEA.

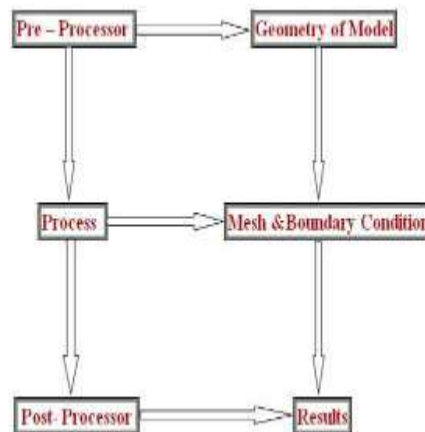

Fig. 1 Typical FEA procedures by commercial software (ANSYS-12)[6]

### B. Materials for Spring

Plain carbon steel, Chromium vanadium steel, Chromium- Nickel- Molybdenum steel, Silicon manganese steel, are the typical materials that are used in the design of leaf springs. The material selected for steel leaf spring is 65Si7 and for composite spring is E-Glass/ Epoxy. The design parameters selected for spring are listed in table I, II, III.

Table I : Design Parameters of Steel Leaf Spring.[6]

Parameters	Values
Material selected Steel	65Si7
Tensile strength	1962 N/mm <sup>2</sup>
Yield strength	1470 N/mm <sup>2</sup>
Young's modulus(E)	2e5 N/mm <sup>2</sup>
Total length	650 mm

Arc height at axle seat	76 mm
Normal static loading (max)	2500 N
Available space for spring width	50 mm X 6 mm
Number of leaves	02

Table II. Design Parameters of Steel V-Shape Strip Spring.

Parameters	Values
Material selected Steel	65Si7
Tensile strength	1962 N/mm <sup>2</sup>
Yield strength	1470 N/mm <sup>2</sup>
Young's modulus(E)	2e5 N/mm <sup>2</sup>

Total length between V end	100 mm
Included angle of V- shape	45 <sup>0</sup>
Normal static loading (max)	2500 N
Available space for spring width	30 mm X 4 mm
Number of strip	01

Table III. :Material properties of E-Glass/Epoxy

Parameters	Values
Tensile modulus along X-direction (Ex), MPa	34000
Tensile modulus along Y-direction (Ey), MPa	6530
Tensile modulus along Z-direction (Ez), MPa	6530
Tensile strength of the material, MPa	900
Compressive strength of the material, MPa	450
Shear modulus along XY-direction (Gxy), MPa	2433
Shear modulus along YZ-direction (Gyz), MPa	1698
Shear modulus along ZX-direction (Gzx), MPa	2433
Poisson ratio along XY-direction (NUxy)	0.217
Poisson ratio along YZ-direction (NUyz)	0.366
Poisson ratio along ZX-direction (NUzx)	0.217
Mass density of the material (ρ), kg/mm <sup>3</sup>	2.6e6

**C. Geometry of Main Leaf Spring & V- Shape Strip Spring**

Figure 2 shows the imported geometry of mono leaf spring & figure 3 shows the imported geometry of V-shape strip spring. This geometry has been created in Pro-E. Figure shows the 3D model of leaf spring with camber of leaf spring. Total length of mono leaf is 650mm and 76mm is the arc height at axel seat.



Fig. 2 Geometry of Main Leaf Spring. Fig. 3 Geometry of V- Shape Strip Spring.



#### ***D. Meshed Model of Main Leaf Spring & V- Shape Strip Spring***

Meshing is nothing but the description of object into the small parts called as the element. Figure 4 & figure 5 shows the meshed model of both spring with brick and triangular elements are used. Previous Studies show that the best results are obtained using brick mesh.

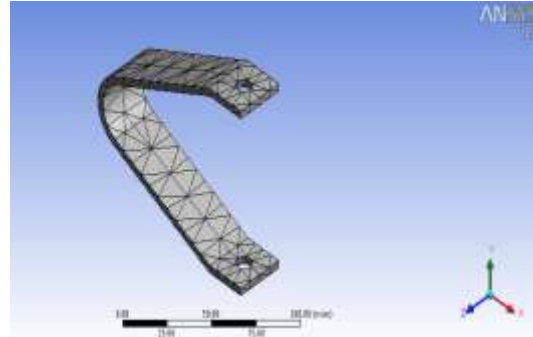
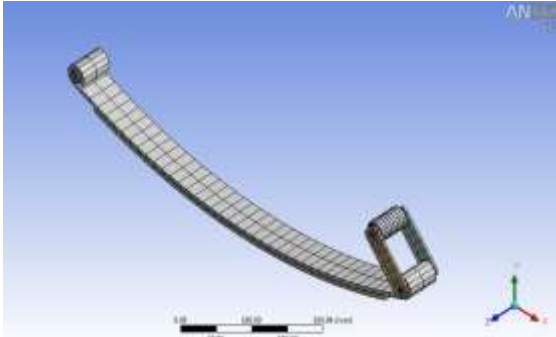

Fig. 4 Meshed Model of Main Leaf Spring. Fig. 5 Meshed Model of V- Shape Strip Spring.

#### ***E. Loading & Boundary Conditions Main Leaf Spring & V- Shape Strip Spring***

##### ***1) Fixed Support***

Fixed support has restriction to move in X and Y direction as well as rotation about that particular point. For the leaf spring analysis one eye end of the leaf spring is fixed to the chassis of the vehicle. So this eye end of the leaf spring cannot move in any of the directions i.e. all the degrees of freedom are blocked. V- shape strip spring expands & compress in up and down direction so it has no any fixed support but it firmly attached with main leaf spring at up side & bracket at down side in assembly of whole unit.

##### ***2) Displacement support***

As there is shackle provided at other end of the leaf spring because of which the leaf spring only translates in one plane and other movements i.e. degree of freedom are blocked. So with the reference of this a displacement support is applied to the other eye end of leaf spring model. This support allows the movement of the leaf spring in X axis, rotation about Z axis and fixed along Y axis.[6] Also for V-shape strip spring curvature end having free movement in X & Y axis Direction but constant in Z axis.

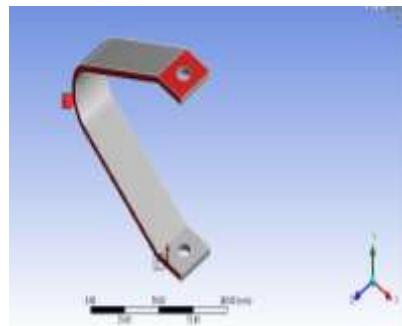
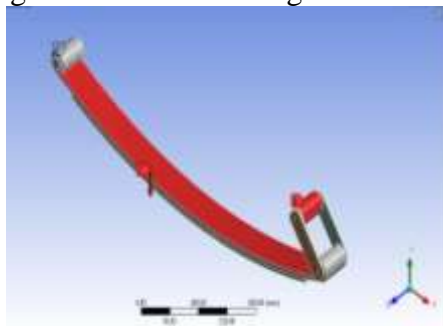

Fig. 6 Loading & Boundary Conditions

Fig. 7 Loading & Boundary Conditions of Main Leaf Spring of V-Shape Spring.

Since the load is uniformly distributed on the leaf spring, here in this study uniformly distributed load 1380N which is 20% more of the unladen weight of trailer. For V- shape strip spring it uniformly distributed load 690N that is applied on doth side from upward and downward of spring model. The uniformly distributed load is shown in figure 6 & figure 7.

**F. Results and Discussion**

**1) Total Deflection of Main Leaf Spring & V- Shape Strip Spring.**

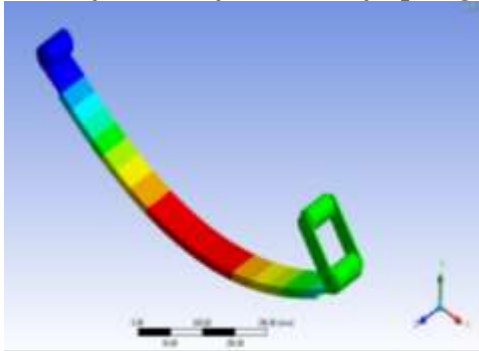

Fig. 8 Total Deflection of Main Leaf Spring.

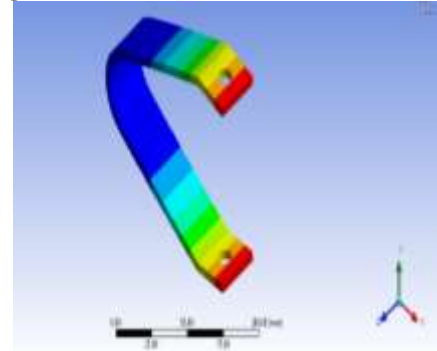

Fig. 9 Total Deflection of V- Shape Strip Spring

Figure 8 shows the deflection of steel leaf spring & Figure 9 shows the deflection of steel V- shape strip spring with leaf spring under the application of 1380N total load. The maximum deflection is at the centre of the leaf spring is 1.71 mm and V- shape strip spring its maximum value is 10.10mm from both side. Red zone indicates the area of maximum deflection and blue zone indicates the area of minimum deflection, which are shown by color band. According to this v- shape spring shows the 16.93 % more deflection than leaf spring.

**2) Stress for Main Leaf Spring & V- Shape Strip Spring.**

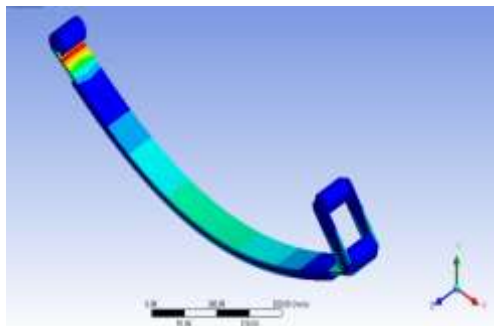

Fig. 10 Stress for Main Leaf Spring.

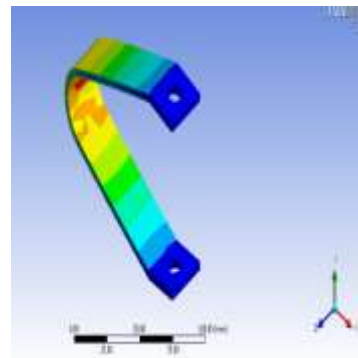

Fig. 11 Stress for V- Shape Strip Spring

Figure 10 & figure 11 shows the equivalent von-mises stress induced in steel leaf spring and V- shape strip spring under the action of 1380N load. The maximum stress is induced at nearer to fixed eye end of leaf spring and the curvature end of V- shape strip spring its maximum value is  $150.8\text{N/mm}^2$  &  $870.42\text{N/mm}^2$  respectively. Red zone indicates the area of maximum stress and blue zone indicates the area of minimum stress.

**3) Strain Energy for Main Leaf Spring & V- Shape Strip Spring:**

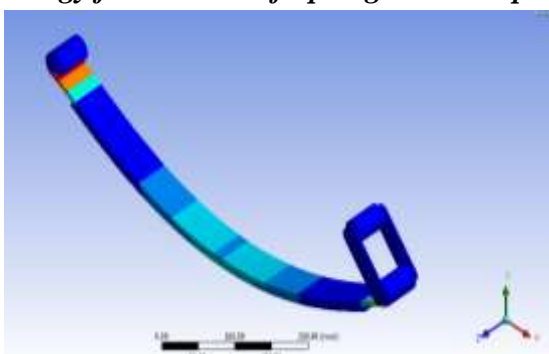

Fig. 12 Strain for Main Leaf Spring.

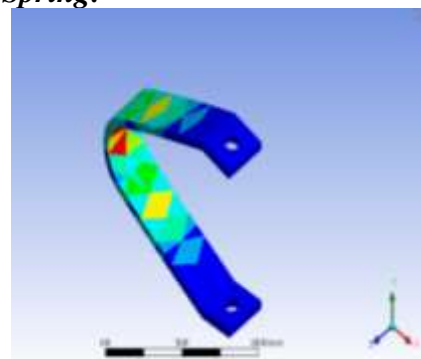

Fig. 13 Strain for V- Shape Strip Spring.

Figure 12 & figure 13 shows the strain energy induced in steel leaf spring and V- shape strip spring

under the action of 1380N load. The maximum strain energy is induced at nearer to fixed eye end of leaf spring and the curvature end of V-shape strip spring its maximum value is 27.998MJ & 73.283MJ respectively. Red zone indicates the area of maximum stress and blue zone indicates the area of minimum stress.



**Fig 3:** V-Strip Suspension spring

#### IV. RESULT AND DISCUSSION

##### 4.1 COMPARATIVE RESULT OF COMPOSITE V-SPRINGS

During the course of work, the Analytical and software work has been carried out for the Composite V- shape strip spring with constant and variable thickness and result. The analytical work carried out and numerical analysis (FEA) carried on ANSYS15. In this chapter the comparison of Composite V-spring (with constant and variable thickness) and Composite V-spring spring concern with Deflection and Stress, those are shown graphically and discussed.

##### 4.1.1 Deflection for Constant Thickness Composite V-Spring, Variable Thickness Composite V-Spring.

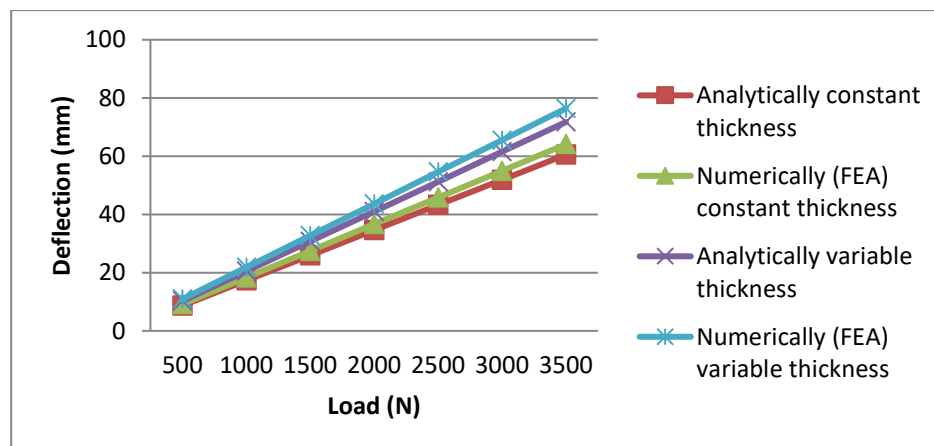

**Figure 4.1:** Comparative load Vs deflection

Figure 4.1 shows the comparative results of load Vs deflection of V-spring (with constant thickness), V-spring (with variable thickness). The above graph clearly shows the V- spring (with constant thickness) has maximum deflection for concern load and minimum deflection for concern load. V- Spring (with variable thickness) has optimum result of deflection for concern load. Therefore V-spring (with variable thickness) is best suitable for part loading

##### 4.2 COMPARATIVE RESULT OF DEFLECTION

##### 4.2.1 Constant Thickness V-Spring under Analytical, Numerical (FEA),



**Table 4.1: Load and deflection value for Composite V-spring (with constant thickness)**

Load (N)		500	1000	1500	2000	2500	3000	3500
Deflection (mm)	Analytically	8.64	17.29	25.93	34.58	43.22	51.87	60.52
	Numerically (FEA)	9.15	18.32	27.47	36.63	45.79	54.95	64.11

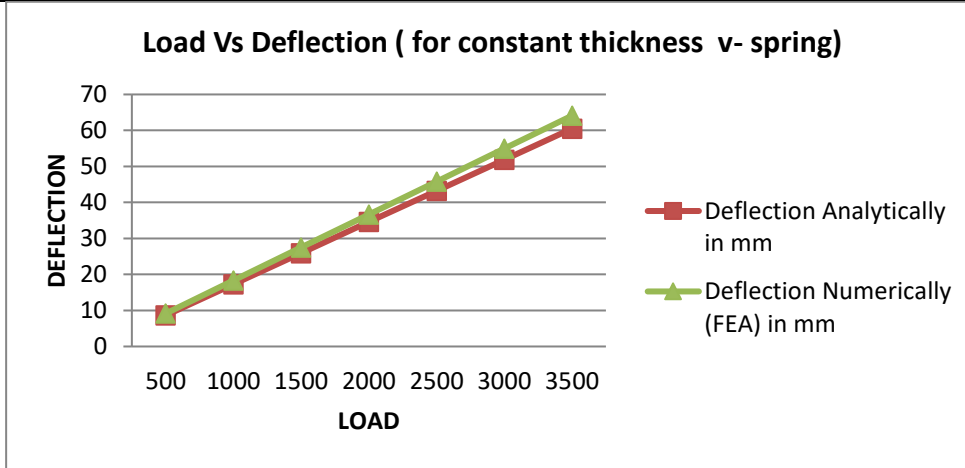

**Figure 4.2: Comparative load vs deflection of V- spring (with constant thickness)**

Figure 4.2 shows the comparative results of load Vs deflection of V-spring (with constant thickness). The above graph clearly shows the V- spring (with constant thickness) has nearly closest result. So this is meaning, it satisfies analytical, numerical (FEA).

**4.2.2 Variable Thickness V-Spring under Analytical, Numerical (FEA)**

**Table 4.2: Load and deflection value for V-spring (with variable thickness)**

Load (N)		500	1000	1500	2000	2500	3000	3500
Deflection (mm)	Analytically	10.24	20.49	30.74	40.98	51.23	61.48	71.72
	Numerically (FEA)	10.91	21.83	32.74	43.65	54.57	65.48	76.40

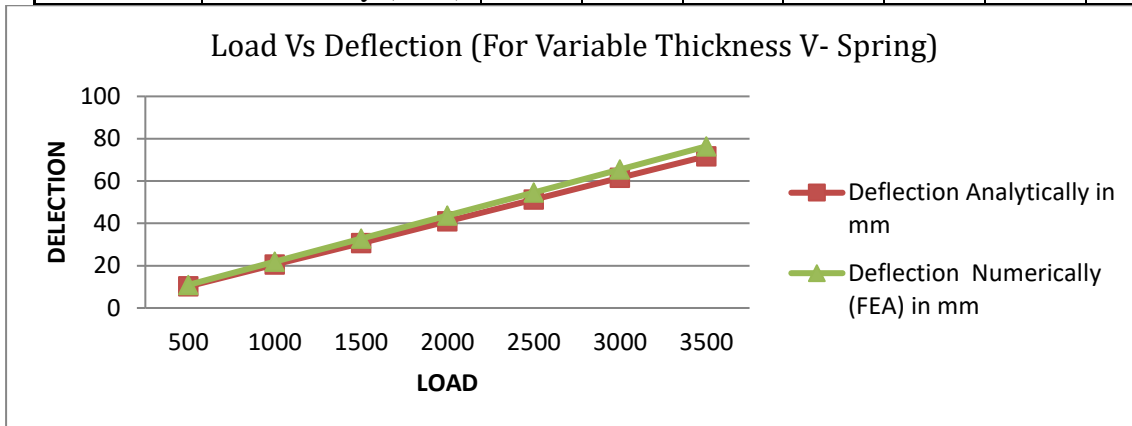

**Figure 4.3: Comparative load vs deflection of V- spring (with variable thickness)**

Figure 4.3 shows the comparative results of load Vs deflection of V-spring (with variable thickness). The above graph clearly shows the V- spring (with variable thickness) has nearly closest result. So this is meaning, it satisfies analytical, numerical (FEA). Therefore the derived analytical formulation for finding the deflection of V-spring has completely validated.

**4.3 COMPARATIVE RESULT OF STRESS INDUCED IN COMPOSITE V-SPRING**

**4.3.1 Constant Thickness V-Spring under Analytical, Numerical (FEA)**

**Table 4.3: Load and stress value for V- spring (with constant thickness)**

Load (N)		500	1000	1500	2000	2500	3000	3500
Stress	Analytical	11.78	23.57	35.36	47.15	58.94	70.72	82.51

(N/mm <sup>2</sup> )	y							
	Numerical y (FEA)	13.01	26.02	39.03	52.04	65.05	78.06	91.07

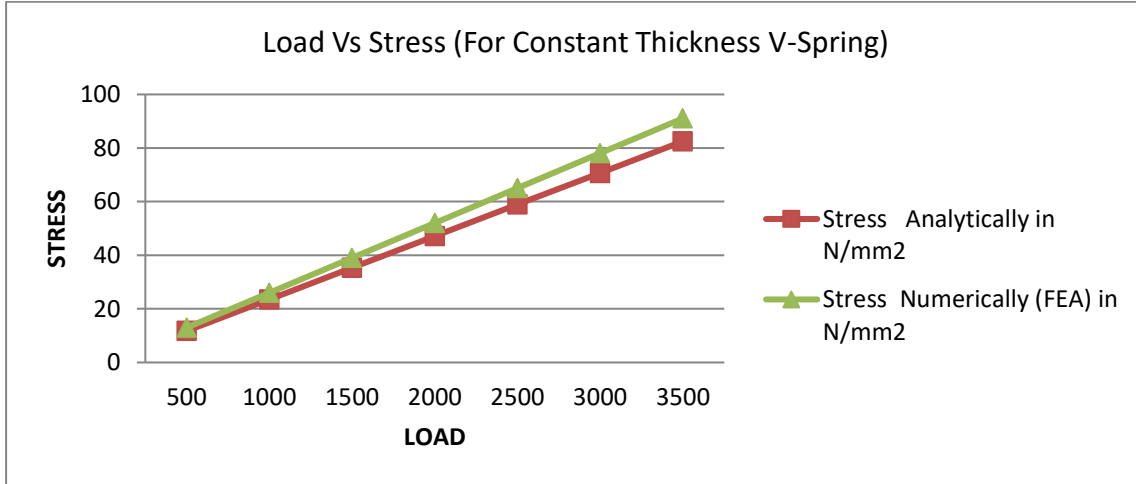

Figure 4.4: Comparative load vs stress of V- spring (with constant thickness)

Figure 6.4 shows the comparative results of load vs stress of V-spring (with constant thickness). The above graph clearly shows the V- spring (with constant thickness) has nearly closest result. So this is mean, derived analytical method for finding bending stress of V-spring satisfy with numerical (FEA) result.

#### 4.3.2 Variable Thickness V-Spring under Analytical, Numerical (FEA)

Table 4.4: Load and stress value for V- spring (with variable thickness)

Load (N)		500	1000	1500	2000	2500	3000	3500
Stress (N/mm <sup>2</sup> )	Analytical y	18.861	37.72	56.58	75.44	94.30	113.1	132.0
	Numerical y (FEA)	24.88	49.76	74.64	99.52	124.4	149.2	174.16

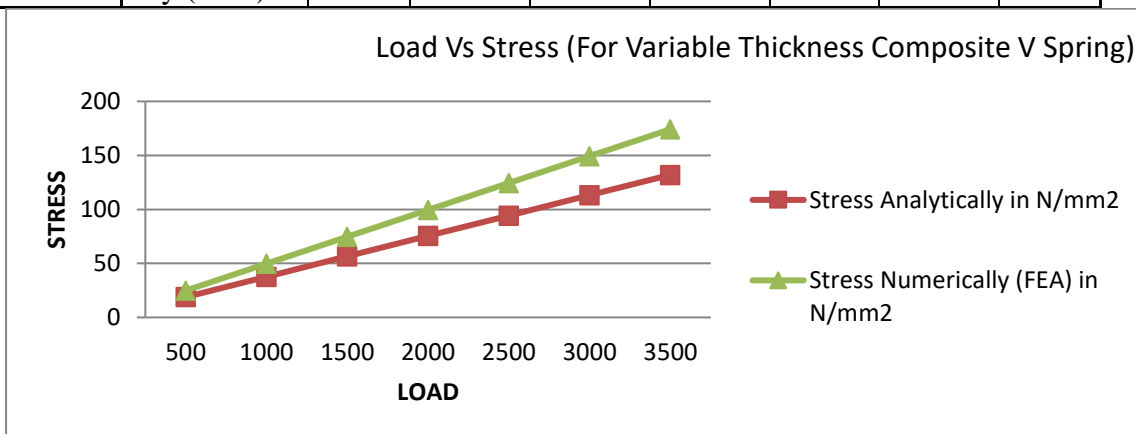

Figure 4.5: Comparative load vs stress of V- spring (with variable thickness)

Figure 4.5 shows the comparative results of load vs stress of V-spring (with variable thickness). The above graph clearly shows the V- spring (with variable thickness) has nearly closest result of analytical & FEA. So this is mean, derived analytical method for finding bending stress of V-spring satisfy with numerical (FEA) result.

**4.4 Analysis Result**

**Table 4.5: Load, Deflection, Stress, Strain Energy, Elastic Strain value for Composite V spring with variable thickness**

Sr.No	Load Value	Deflection	Stress	Strain Energy	Elastic Strain
	500	10.9	24.88	104.32	0.0029
	1000	21.83	49.76	417.28	0.0059
	1500	32.74	74.64	938.87	0.0088
	2000	43.65	99.52	1669.1	0.0118
	2500	54.57	124.4	2608	0.0148
	3000	65.48	149.28	3755.5	0.0177
	3500	76.4	174.16	5111.6	0.0207

Weight : 3.77 kg

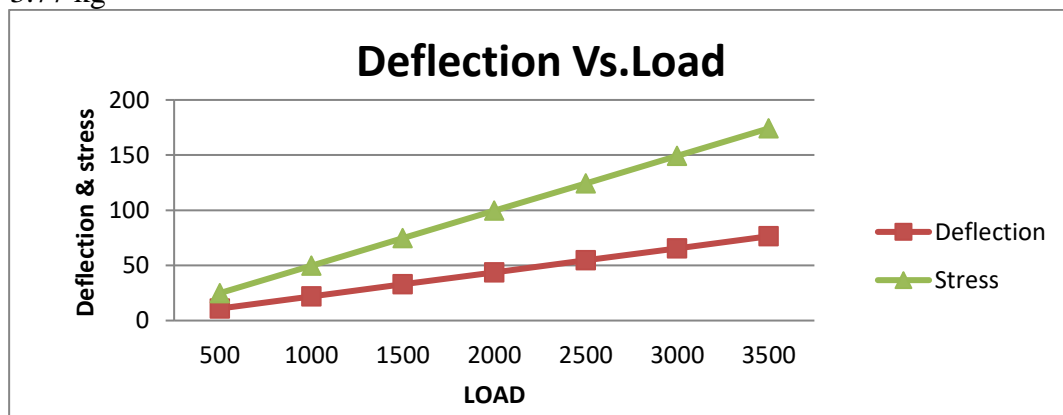
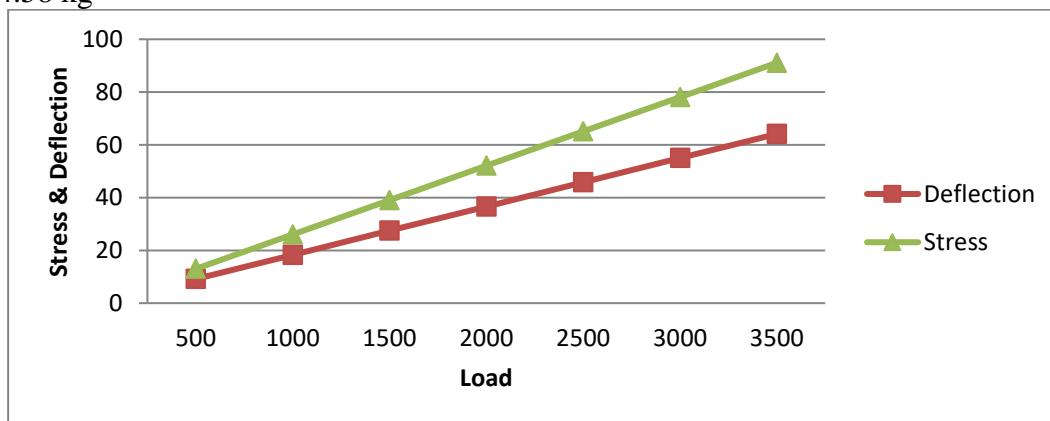

**Figure 4.6: Comparative load vs stress of V- spring (with variable thickness)**

**Table 4.6: Load, Deflection, Stress, Strain Energy, Elastic Strain value for Composite V spring with constant thickness**

Sr.No	Load Value	Deflection	Stress	Strain Energy	Elastic Strain
1.	500	9.15	13.01	28.55	0.0023
2.	1000	18.32	26.02	114.24	0.0047
3.	1500	27.47	39.03	257.03	0.007
4.	2000	36.63	52.04	456.95	0.0094
5.	2500	45.79	65.05	713.98	0.0117
6.	3000	54.95	78.06	1028.1	0.0141
7.	3500	64.11	91.07	1399.41	0.0164

Weight: 4.58 kg



**Figure 4.7. Comparative load vs stress and deflection of V- spring (with constant thickness)**



## V. ADVANTAGES

- It is light in weight and strong.
- Provides good mitigation action.
  
- Provides good support for axle and chassis.
- Easy to build.
- It can withstand a large amount of load compared to helical springs.

## VI. DISADVANTAGES

- The comfort of the ride is not good because of the collision of the leaves between each leaf.
- Over time, springs often lose shape and may collapse.
- If the sag is uneven, it can change the contrasting weight of the car which can affect the handling less.

## VII. CONCLUSION

From this project, we conclude that the V-Strip suspension spring has more strength, stiffness and elasticity as compare to leaf spring. The material of V-strip suspension spring also lighter in weight and durable. This suspension spring is most suitable and useful for Mini Tractor's trolley for carrying fruits and can transport it safely from farm to market or other places. This work is concerned with recent research in suspension system design. In the introduced innovations, advanced mechanical mechanisms were designed analyzed and implemented into the start to be applied to real vehicles. The application of the composite V shape spring as a shock absorber device to enhances performance of suspension. With its advantages, axle-less suspension with progressive rate spring unit should be extensively applied in future for all vehicle suspension systems. This unit gets replaced with dead axle.

This suspension unit is used as a sole suspension which provides high performance per unit weight. The V- spring unit with composite material is gradually brought into operation according to the load being applied and progressively increases in proportion to the load being carried. Initial take-up is very smooth and the spring rate increase is progressive, resulting in a greatly improved ride, improved load handling, greater load stability and longer spring life. This suspensions unit undergoes reversible elastic deformation and act as vibration isolators. It can withstand or severe shock loads at minimum to maximum capacity without bottoming out which greatly reduces forces transmitted to the frame.

In this work core part that is mathematical derivation of Total Deflection and Maximum Stress for concern load. Therefore in the present work, V-Spring is design by using derived formulas and it satisfied with the FEA result.

The 3-D modeling of both steel spring is done and analyzed A comparative study has been made between V- shape strip spring and leaf spring with respect to Total deflection, von-miss stresses and strain energy. From the results, It is observed that the V- shape strip spring shows more deflection i.e 16 % and strain energy 38.20 % than that of steel leaf spring material. It is observed that the V- shape strip spring is great under part loading i.e. minimum loading action and main leaf spring is superior for maximum loading condition so that the whole unit of this progressive rate spring is best suitable for fruit carrying trailer and mini ambulance vehicle. The V- spring unit is gradually brought into operation according to the load being applied and progressively increases in proportion to the load being carried and also it is more economical thanthe conventional steel spring with similar design specifications.

This spring unit is best suitable for fruit carrying trailer and regular trailer used in agricultural field and also it is more economical than the conventional steel spring with similar design specifications.

### Future developments and scope

This work is concerned with recent research of Composite V-Spring design used as suspension system for mini trailer in agriculture sector. In the introduced innovations, advanced mechanical mechanisms were designed analyzed and implemented. The application of the shock absorber devices to be



continuously controlled therefore apparently enhances its performance. With its advantages, V-Spring suspension with progressive rate spring unit and damper should be extensively applied in future for all vehicle suspension systems.

## VIII. REFERENCES

- 1)Rajeswaran, Ahamed, Suspension system in automobiles, PHI Learning Private Limited, New Delhi- 01, pp. 25-45, 614–625.
- 2) Trailer / Body Builders Journal, on “Trailer Independent Suspension a Huge Success”, Australia. October 2000.
- 3) Kristin R. Brandenburg, John R. Keough. Independent Trailer Suspension Utilizing Unique ADI Bracket by Applied Process Inc. Technologies Div. - Livonia, Michigan, USA, 2002.
- 4) Firat Barlas Izmir , on Design of a Mars Rover Suspension Mechanism, Institute of Technology Izmir, Turkey, June 2004.
- 5) Timbren Industries Inc- ID10895 Axle-Less Trailer Suspension, 2010.
- 6 )K.N. Patil “Analysis of Steel and Composite Leaf Spring for Vehicle” IOSR Journal of Mechanical and Civil Engineering (IOSR-JMCE). Volume 5, Issue 4, PP 68-76, Jan. - Feb. 2013.
- A. C. Baviskar, V. G. Bhamre, S. S. Sarode. “Design and Analysis of a Leaf Spring for automobile suspension system: A Review” International Journal of Emerging Technology and Advanced Engineering. Volume 3, Issue 6, June 2013.
- 7) Lokhande, A. D., Shrivastava, R. L., & Shrivastava, R. R. (2014). A REVIEW ON CRITICAL SUCCESS FACTORS OF RE-MANUFACTURING. *International Journal of Entrepreneurship & Business Environment Perspectives*, 3(2), 982
- 8) Shrivastava, R. L, Lokhande, A. D (2016). LINKAGE BETWEEN EFFORT FACTORS AND ORGANIZATIONAL PERFORMANCE: REMANUFACTURING INDUSTRY. *International Journal of Management and Research*, 3,301-310
- 9) Shrivastava, R. L, Lokhande, A. D (2015). DESIGN OF FRAMEWORK FOR IMPLEMENTATION OF CSFS IN REMANUFACTURING INDUSTRIES FOR PERFORMANCE IMPROVEMENT. *Industrial Engineering Journal*. 9(7).39-45.
- 10) Shrivastava, R. R.,Lokhande, A. D., & Shrivastava, R. L.(2015). “IDENTIFICATION AND EVALUATION OF CRITICAL FACTORS FOR PERFORMANCE IMPROVEMENT FOR REMANUFACTURING INDUSTRY” - A PILOT STUDY. *International Journal of Applied Engineering Research*. 10(11).10328-10335
- 11“E. WIELANDT” AND “G. STRECKEISEN”(1982), THE LEAF-SPRING SEISMOMETER: DESIGN AND PERFORMANCE, Vol. 72, No. 6, pp. 2349-2367
12. Prof. N.P.Dhoshi1 , Prof .N.K.INGOLE2 , Prof .U.D.GULHANE, Analysis and Modification of Leaf Spring of Tractor Trailer Using Analytical and Finite Element Method, Vol.1, Issue.2, pp-719-722
13. Y.S. Kong a , S. Abdullah a,b, M.Z. Omar a,b,\*, S.M. Haris.(2016), Failure assessment of a leaf spring eye design under various load cases, [Volume 63](#), May 2016, Pages 146-159
- 14.Rajendra,S.Vijayarangan,(1999),Optimal design of a composite leaf spring using henetic algorithm,computer and structure 79(2001)1121-1129
15. Dipendra Kumar Roya and Kashi Nath Sahab \*,(2013) Nonlinear Analysis of Leaf Springs of Functionally Graded Materials, *Procedia Engineering* 51 ( 2013 ) 538 – 543
16. Mahmood M. Shokrieh \*, Davood Rezaei(2003), Analysis and optimization of a composite leaf spring, *Composite Structures* 60 (2003) 317–325
17. Hayder H. Khaleel, Assaad Al Sahlani, Noor H. Dhaher and Nawfel M. Baqer(2018), MODELING AND ANALYSIS OF LEAF SPRING USING FINITE ELEMENTS METHOD, Volume 9, Issue 6, June 2018, pp. 48–56, Article ID: IJMET\_09\_06\_007
18. Sreenesh Valiyandi(2021), Dynamic Analysis of Leaf Spring with Structural steel, Albamet, and Fiber Glass,Vol.9, Issue.2, pp.01-05
19. SIVANAND. A1 , DEVANATHAN. C2 , Dr. SANTHANAM. V3 & DHANARAJ. R,(2020), DESIGN AND OPTIMIZATION OF GLASS FIBRE REINFORCED POLYMER COMPOSITE LEAF SPRING, Vol. 10, Issue 3, Jun 2020, 5045-5052
20. Kalyani Sudhir Kulkarni1 , Prof. V. J. Khot(2015), Design and Development of Mono Leaf Spring by using Composite Material (Epoxy-Carbon Fiber, Vol-2, Issue-12 ISSN: 2349-6495
21. S.Sivanandam[1] Dr. M.Shankar [2] M.Vivekanandhan,(2018), Design And Analysis of Composite Parabolic





- Leaf Spring for Light Vehicles, ISSN (e): 2250-3021, ISSN (p): 2278-8719 PP 23-38
22. Dara Ashok 1 , M.V. Mallikarjun2 and Venkata Ramesh Mamilla3(2012), DESIGN AND STRUCTURAL ANALYSIS OF COMPOSITE MULTI LEAF SPRING, ISSN 2249-6149 Issue 2, Vol.5
  23. K. K. Sharma1 , S. R. Mandale, K. K. Sharma1 , S. R. MandaleISSN (e): 2250-3021, ISSN (p): 2278-8719 PP 29-33
  24. sunil chinha, N Jeevan kumar,2013,design and anlysis of leaf spring,global journal of science and technology(special)volimeXII ISSUE I version I
  25. Vivek Rai \*, Gaurav Saxena,2013, Development of a Composite Leaf Spring for a Light Commercial Vehicle (Tata Magic), Vol. 3, Issue 5, Sep-Oct 2013, pp.110-114
  26. Baviskar A. C. 1 , Bhamre V. G. 2 , Sarode S. S.,(2013) Design and Analysis of a Leaf Spring for automobile suspension system: A Review, (ISSN 2250-2459, ISO 9001:2008 Certified Journal, Volume 3
  27. Ritesh Kumar Dewangan\*, Manas Patnaik\*\*, Narendra Yadav(2012), Minimization of Stress of a Parabolic Leaf Spring by Simulated Annealing Algorithm, ISSN: 2248-9622Vol. 2, Issue 4, July-August 2012, pp.457-460
  28. Mr. V. K. Aher \*, Mr. P. M. Sonawane,2012, Static And Fatigue Analysis Of Multi Leaf Spring Used In The Suspension System Of LCV, ) ISSN: 2248-9622, Vol. 2, Issue4, July-August 2012, pp.1786-1791
  29. Achamyelah A Kassiel\*, R Reji Kumar1 and Amrut Rao,2014, DESIGN OF SINGLE COMPOSITE LEAF SPRING FOR LIGHT WEIGHT VEHICLE, ISSN 2278 – 0149 www.ijmerr.com Vol. 3, No. 1,
  30. Gulur Siddaramanna SHIVA SHANKAR\* , Sambagam VIJAYARANGAN,2006, Mono Composite Leaf Spring for Light Weight Vehicle – Design, End Joint Analysis and Testing, ISSN 1392–1320 MATERIALS SCIENCE (MEDŽIAGOTYRA). Vol. 12, No. 3. 2006
  31. Subramanian C, Senthilvelan S. Joint performance of the glass fiber reinforced polypropylene leaf spring. *Compos Struct* 2011;93:759–66.
  32. Collings TA. The strength of bolted joints in multi-directional cfrp laminates. *Composites* 1975;8:43–55.
  33. Stockdale JH, Matthews FL. The effect of clamping pressure on bolt bearing loads in glass fibre-reinforced plastics. *Composites* 1976;7:34–8.
  34. Kretsis G, Matthews FL. The strength of bolted joints in glass fibre/epoxy laminates. *Composites* 1985;16:92–102.
  35. Cooper C, Turvey GJ. Effects of joint geometry and bolt torque on the structural performance of single bolt tension joints in pultruded GRP sheet material. *Compos Struct* 1995;32:217–26.
  36. Camanho PP, Matthews FL. Stress analysis and strength prediction of mechanically fastened joints in FRP: a review. *Compos A Appl Sci Manuf* 1997;28:529–47.
  37. Chen HS. The static and fatigue strength of bolted joints in composites with hygrothermal cycling. *Compos Struct* 2001;52:295–306.
  38. Mccarthy CT, Mccarthy MA, Lawlor VP. Progressive damage analysis of multi-bolt composite joints with variable bolt–hole clearances. *Compos B Eng* 2005;36:290–305.
  39. Aktaş A, İmrek H, Cunedioğlu Y. Experimental and numerical failure analysis of pinned-joints in composite materials. *Compos Struct* 2009;89:459–66.
  40. Gulur Siddaramanna SSVS. Mono composite leaf spring for light weight vehicle— design, end joint analysis and testing. *Mater Sci* 2006;12:6.
  41. Subramanian C, Senthilvelan S. Effect of reinforced fiber length on the joint performance of thermoplastic leaf spring. *Mater Des* 2010;31:3733–41
  42. Subramanian C, Senthilvelan S. Fatigue performance of discontinuous fibre-reinforced thermoplastic leaf spring. *Proc IMechE* 2010;224(3):93–100. <https://doi.org/10.1243/14644207JMDA319>.
  43. Lo KH, McCusker JJ, Gottenberg WG. Composite leaf spring for tank trailer suspensions. *J Reinf Plast Compos* 1987;6:100–12.
  44. Jamadar NI, Kivade SB, Raushan R. Failure analysis of composite mono leaf spring using modal flexibility and curvature method. *J Fail Anal Prev* 2018;18:782–90.
  45. Deshmukh BB, Jaju SB. Design and analysis of glass fiber reinforced polymer (GFRP) leaf spring. 4th International Conference on Emerging Trends in Engineering and Technology, ICETET 2011, November 18, 2011 - November 20, 2011. Hotel Le Meridien, Mauritius: IEEE Computer Society; 2011. p. 82-7.
  46. Suprith N, Annamalai K, Naiju CD, Mahadevan A. Design and analysis of automotive multi-leaf springs using composite materials. 2013 2nd International Conference on Advanced Materials Design and Mechanics, ICAMDM 2013, May 17, 2013 - May 18, 2013. Kuala Lumpur, Malaysia: Trans Tech Publications Ltd; 2013.



p. 533-7.

47. Sedlacek F, Bernardin P, Lasova V. Design of a composite leaf spring for railway vehicles. 27th DAAAM International Symposium on Intelligent Manufacturing and Automation, October 26, 2016 - October 29, 2016. 1 ed. Mostar, Bosnia and herzegovina: Danube Adria Association for Automation and Manufacturing, DAAAM; 2016. p. 493-500.
48. Oztoprak N, Gunes MD, Tanoglu M, Aktas E, Egilmez OO, Senocak C, et al. Developing polymer composite-based leaf spring systems for automotive industry. *Sci Eng Compo Mater* 2018;25:1167–76.
49. Shi W, Qian C, Chen Z, Song Q, Yang S. Establishment of theoretical model of composite leaf springs by using the mechanics of composite materials. *J Reinf Plast Compos* 2017;36:1316–26.
50. Choi B, 오 성 하. Prediction of Spring Rate and Initial Failure Load due to Material Properties of Composite Leaf Spring. *Transactions of the KSME, A*. 2014;38:1345-50.
51. Choi B, 오 성 하. A Numerical Study on Spring Rate of Composite Leaf Spring from Material Parameters. *Journal of the Korean Society of Mechanical Technology*. 2014;16:1279-84.
52. Oh SH, Choi BL. Prediction of spring rate and initial failure load due to material properties of composite leaf spring. *Trans Korean Soc Mech Eng A* 2014;38:1345–50.
53. Ekbote T, Sadashivappa KS, Abdul Budan D. Optimal design and analysis of mono leaf composite spring by finite element analysis. 1st International Conference on Advances in Engineering, Science and Management, ICAESM-2012, March 30, 2012 - March 31, 2012. Nagapattinam, Tamil Nadu, India: IEEE Computer Society; 2012. p. 41-6.
54. Rajesh S, Bhaskar GB, Subash R, Pazhanivel K, Sagadevan SS. Optimization of composite leaf spring design using response surface methodology. *Revista Romana De Materiale-Roma J Mater* 2017;47:98–105.