



Internet of Things (IoT) based Energy Tracking and Bill Estimation System

1) Dr.K.Vanise

Associate Professor & HOD,ECE

Samskruti college of Engineering & Technology

2) S.Mahesh

Research Scholar,ECE

Samskruti college of Engineering and Technology

3) P.Sandeep

Research Scholar,ECE

Samskruti college of Engineering Technology

4)P.Lalith Phani Kumar

Research Scholar,ECE

Samskruti College of Engineering & Technology

5)J.Sarika

Research Scholar,ECE

Samskruti College of Engineering & Technology

Abstract—Electricity is the most requisite energy in modern times. IoT based energy tracking and bill estimation system discussed in this paper has an objective to build awareness among household and industrial consumers about their usage of this energy. This study has specifically focused to develop a IOT Based Prepaid Smart Metering System which would be able to address some of the challenges currently available in the regular digital automated metering system in Eurasia. Smart Metering with its unique performance with the Internet of Things (IoT) tend to be an efficient system for electricity management, secure against the intervention by third parties, and reliable for tracking and real-time remote monitoring. Hence, this project work is accomplished by analyzing available functions and journals on the existing design of Smart Metering and discussed on further preferable application. In the currently working system, electricity meter reading for electricity usage and billing is done by human workers from home to home and building to buildings. The purpose of this project is to develop a Smart Electricity meter using IOT. This can reduce human errors and helps to retrieve the real time meter value via IOT and send it to customers mobile phone through IOT. This also allows electricity board to modify the variable package price in specific duration. The administrator can analyze the customers power consumption data and generate the report from the data online. The prototype will be able to introduce the billing system to the customers, get the power consumption data from smart meter, keep the data in centralized database and generate the report.

This paper comprises a section of Proposed Work, which contains system architecture, hardware design, IoT cloud interface application design, working principle, and system implementation and Result Analysis, which consists of tested results of the intended system.

INTRODUCTION:

Electricity is one of the vital requirements for sustenance of contents of life. It should be used very judiciously for its proper utilization. But in our country, we have lot of locality where we have surplus supply for the electricity while many areas do not even have access to it. Our policies of its distribution are also partially responsible for this because we are still not able to correctly estimate our exact requirement and still power theft is prevailing. On the other hand, consumers are also not satisfied with the services of power companies. Most of the time they have complaints regarding statistical errors in the monthly bills. With this we can monitor meter and track if any fault is there or not. In previous meter a circular metal strip rotates and according to that rotation we calculate the consumption. But our meter works on pulse which is created according to consumption and we previously connected an android board which monitor the pulse and according to pulse the bill is generated. With the help of this project we are aiming to receive the monthly energy consumption from a remote location directly to centralized office. In this way we can reduce human efforts needed to record the meter readings which are till now recorded by visiting every home individually.

Smart energy meter is an electronic device that measures the most accurate amount of electricity consumed by a residence, business or any electrically-powered device. A smart meter is reliable source for most accurate information of consumed energy that reduces the chance of error in the existing billing system to minimal.

LITERATURE SURVEY:

Ashna.K “**IOT Based Automatic Energy Meter Reading System with Instant Billing**” proposed the design of a simple low-cost wireless IOT energy meter and its associated wave interface, for automating billing and managing the collected data globally.

Vivek Kumar Sehgal “**Electronic Energy Meter with Instant Billing**” introduced the concept of Postpaid Energy Meter which automatically sense the energy used in the home and when it reaches value which is initially fed in the hardware it will disconnect the power line. A user interface given in the hardware for user which will interact with the hardware, through user interface user can set a value

Ms. Prajakta B.Murmude, Mr. Sachin G. Jagdale, Ms. Sunita D. Giri “**IOT based Prepaid Energy Meter**” proposed the design and implementation of a IOT based remote operation of an energy meter which gives the solution to power theft, consumption control, auto billing and payment, data logging and Manpower reduction in power distribution and management.

BLOCKDIAGRAM,

EXISTING PREPAID METERING TECHNOLOGIES:

• **SMART CARD based prepaid Energy Meters:**

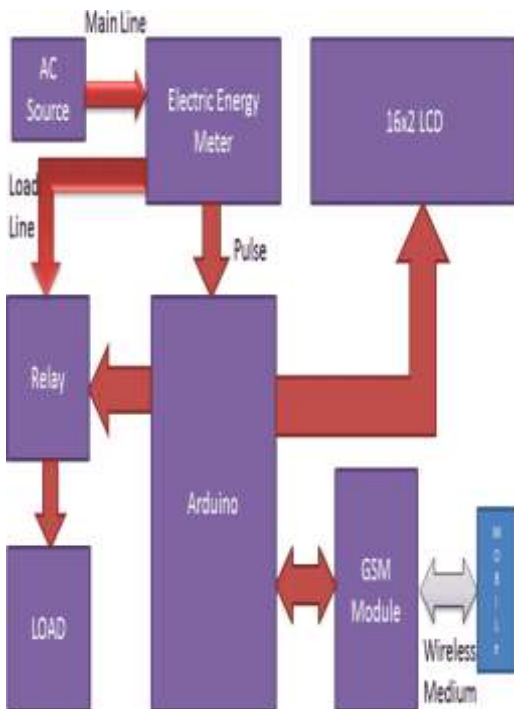

Smart card is a credit card sized plastic card embedded with an integrated circuit (IC) and usually it consists of a ROM, EEPROM and a CPU. A smart card provides both the memory

capacity and the computational capability [5]. Access to data stored on the card is under the control of the smart card operating system. In this method consumer have to have the smart card recharged for the amount he chooses and enter the card into the card reader of the energy meter. Then the meter store the number of units recharged and start to measures the energy consumption. When purchased units are used up the meter disconnect the power supply until the next recharge.

• **RFID (Radio-Frequency Identification) based Prepaid Energy Meters:**

Radio-frequency identification (RFID) is an automatic identification method, relying on storing and remotely retrieving data using devices called RFID tags or transponders. The technology requires some extent of cooperation of an RFID reader and an RFID tag. An RFID tag is an object that can be applied to or incorporated into a product, animal, or person for the purpose of identification and tracking using radio waves. Some tags can be read from several meters away and beyond the line of sight of the reader. In this method RFID cards which are issued by the electricity suppliers to individual consumers are used. This RFID card is unique with a code in it and consumers are free to make flexible recharge. When the consumer wants to use the system, he needs to show the card to the reader, then the unique code inside the card is recognized by the reader, and starts deducing the amount of the RFID card as per the quantized unit charge. When the usage completes the consumer has to recharge the RFID card again.

In this project the

IOT Based Prepaid Smart metering system Includes:

- Meter, which is used to measure the flow of electric power from input to the output terminal.
- LCD Display, which is used for displaying readings of the parameters that are being measured.
- IOT module is used for communication with the end user and it is responsible for updating the data on the distribution side

PROPOSED SYSTEM:

This mechanism requires the consumers to pay for the electricity before its consumption. On that way, users hold credit and then use the electricity until the credit is ended. If the available credit is ended then the electricity supply is cut-off by a relay. Readings made by operators are prone to errors. This project shows the above mentioned problems. These system will first register the user. For making recharge the consumer must have to login to the system. The username and



password must create to login then it will check for the user is valid or not through server. It can able to recharge through user phone app only if the user is authorized user. As recharge ends it will cut off the electricity.



HARDWARE DESCRIPTION

ARDUINO UNO



Arduino UNO is a microcontroller board based on the ATmega328P. It has 14 digital input/output pins (of which 6 can be used as PWM outputs), 6 analog inputs, a 16 MHz ceramic resonator, a USB connection, a power jack, an ICSP header and a reset button.

Electric Meter



Energy meter is the meter which is used for measuring the energy utilized by electric load. The energy is the total power consumed and utilized by the load at a particular interval of time.

LCD (Liquid Crystal Display)

LCD (Liquid Crystal Display) is a type of flat panel display which uses liquid crystals in its primary form of operation.

Wi-fi module esp8266

Wi-Fi module delivers highly integrated WI-FI solution to meet users for continuous demand of efficient power usage.



Relay



A relay is an electrically operated switch. It consists of a set of input terminals for a single or multiple control signals, and a set of operating contact terminals

LDR Sensor

LDRs are tiny light-sensing devices also known as photoresistors. An LDR is a resistor whose resistance changes as the amount of light falling on it changes.

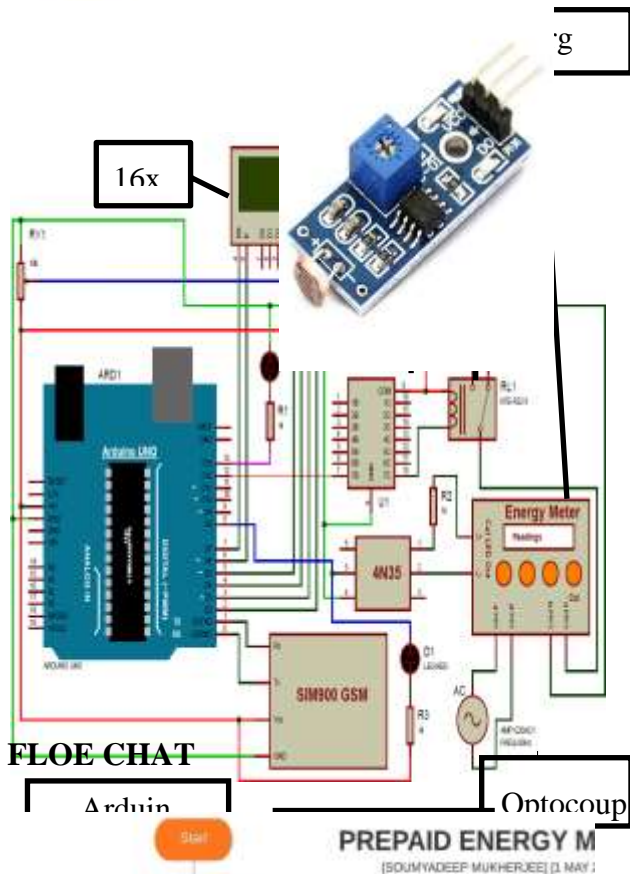

FLOE CHAT

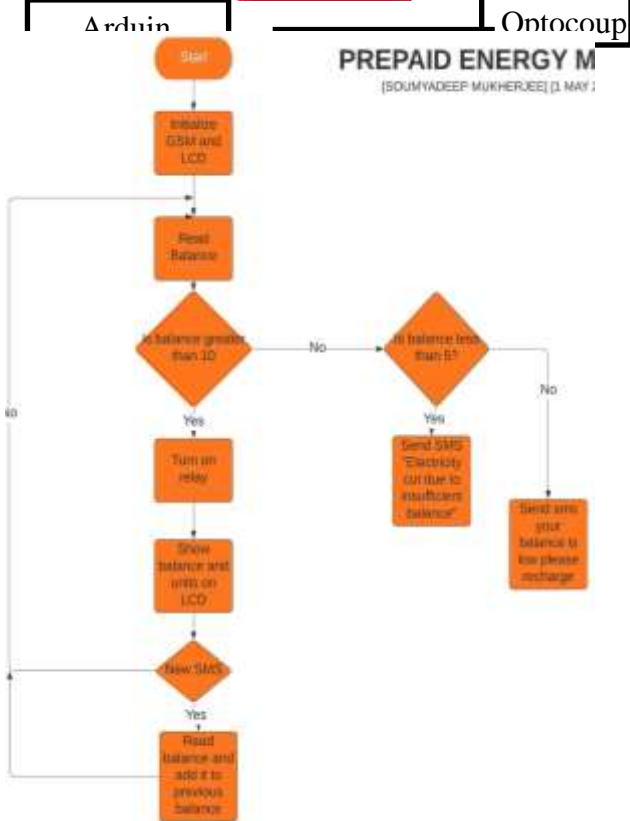

CIRCUIT DIAGRAM

OBSERVATION AND RESULTS:

The system is being initialised. The Arduino is trying to establish connection with the components.

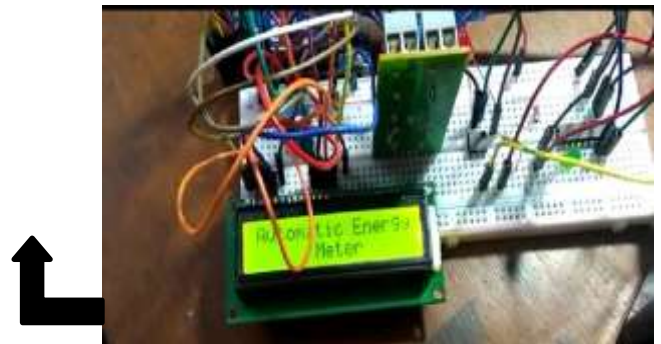

The Arduino establishes connection with the IOT 900 module.



The system finally shows the available unit and balance

CONCLUSIONS:

1. By using this project, we can reduce the manual effort to take the reading from the energy meter which is cost effective.
2. Divergence in service is going to be the key competitive factor to the improve market share in the present power markets prepaid meters with their advantages over conventional ones are likely to help power providers to differentiate and offer value –added services to users.
3. Encourage clients to opt for prepaid meters on a voluntary basis and offering tariff or non-tariff incentives to those users who prepaid their power changes would help the utilities to execute this system.
4. Reduces man power.
5. It is user friendly and we can enhance this project, in which an electricity department can send message to the consumer about the billing information.

FUTURE SCOPE:

This is 21st century and there is no space for errors or faults either in any technical system or in general applications. Prepaid energy meter is a beneficial concept for the future. It’s facilitates the remission from electricity bills.

I. CONCLUSION

IoT based energy tracking and bill estimation system discussed in this paper with various sections is successful in building awareness about electricity usage by displaying real-time estimated electricity consumption by each connected to it and real-time estimated bill of total consumption on monitor unit built-in IoT cloud interface. It has a simple design as it fetches the average consumption detail of loads from a cloud- hosted database and not uses any chips or sensors to measure electricity, current, and voltage. It also has additional features of logging the final estimated bill of each month to a cloud- hosted database and transmitting switching instructions for loads via a control unit built-in IoT cloud interface. The simplistic design and implementation of extra

Electricity vouchers will be available at nearby shops. The word prepaid means ‘pay before use’ one of the beneficial feature of this concept prepaid energy meter is used to prepaid the current supply of electricity to homes, offices etc.

REFERENCES:

1. <https://github.com>
2. <https://randomnerdtutorials.com/guide-for-relay-module-with-arduino/>
3. <https://www.icccn.org>
4. <https://www.instructables.com/id/IOT-SIM900A-With-Arduino/>
5. International Journal of Advanced Computer Science and Applications: Modelling of Arduino-based Prepaid Energy Meter using IOT Technology
6. <https://circuitdigest.com>
7. <https://www.arduino.cc/en/guide/environment>
8. <https://iot-analytics.com/10-internet-of-things-applications/>
9. E. I. Abbas, M. E. Safi and M. A. Jaber, "Design and Implementation Prepaid Energy Meter Supported by RFID and IOT Technologies," 2018 International Conference on Advanced Science and Engineering (ICOASE),Duhok,2018,pp.216-220, doi:10.
10. Shanaka Lakmal, Isuru & Rodrigo, Asanka. (2016). A Prepaid Energy Meter Using GPRS/IOT Technology For Improved Metering And Billing.
11. Surajudeen-Bakinde, Nazmat & AYODELE, Sunday & Oloruntoba, Timilehin & Otuoze, Abdulrahman & Faruk, Nasir. (2017). Development of an Internet Based Prepaid Energy Meter. 10.1109/AFRCON.2017.8095681.
12. N. Mohammad, A. Barua and M. A. Arafat, "A smart prepaid energy metering system to control electricity theft," 2013 International Conference on Power, Energy and Control (ICPEC), Sri Rangelatchum Dindigul, 2013, pp. 562-565, doi: 10.1109/ICPEC.2013.6527721.

features were possible by utilizing the concept of the Internet of Things (IoT) in the proposed system.

REFERENCES

- [1] Bhalaji, N. "EL DAPP–An Electricity Meter Tracking Decentralized Application." Journal of Electronics 2, no. 01 (2020): 49-71.
- [2] A. Y. Devadhanishini, R. K. Malasri, N. Nandinipriya, V. Subashini and P. G. Padma Gowri, "Smart Power Monitoring System Using Iot," 2019 5th International Conference on Advanced Computing & Communication Systems (ICACCS), Coimbatore, India, 2019, pp. 813-816.
- [3] M. J. Islam Mozumder and S. Ghosh, "IoT Based Automatic Electricity Monitoring and Remote Load Control System Using PIC18F4550," 2018 9th International Conference on Computing, Communication and Networking Technologies (ICCCNT), Bangalore, 2018, pp. 1-4.

Fig. 9. Estimated Bill Entries Logged in Database.



- [4] K. Chooruang and K. Meekul, "Design of an IoT Energy Monitoring System," 2018 16th International Conference on ICT and Knowledge Engineering (ICT&KE), Bangkok, 2018, pp. 1-4.
- [5] D. Lestari, I. D. Wahyono and I. Fadlika, "IoT based Electrical Energy Consumption Monitoring System Prototype: Case study in G4 Building Universitas Negeri Malang," 2017 International Conference on Sustainable Information Engineering and Technology (SIET), Malang, 2017, pp. 342-347.
- [6] A. Chaudhari, B. Rodrigues and S. More, "Automated IOT based system for home automation and prediction of electricity usage and comparative analysis of various electricity providers: SmartPlug," 2016 2nd International Conference on Contemporary Computing and Informatics (IC3I), Noida, 2016, pp. 390-392.
- [7] K. B. Tarase and V. M. Panchade, "Monitoring & Controlling of Substation Using IoT in Distribution Power Grid," 2020 5th International Conference on Devices, Circuits and Systems (ICDCS), Coimbatore, India, 2020, pp. 66-70.
- [8] W. T. Hartman, A. Hansen, E. Vasquez, S. El-Tawab and K. Altaii, "Energy monitoring and control using Internet of Things (IoT) system," 2018 Systems and Information Engineering Design Symposium (SIEDS), Charlottesville, VA, 2018, pp. 13-18.
- [9] Z. H. Che Soh, I. H. Hamzah, S. A. Che Abdullah, M. A. Shafie, S. N. Sulaiman and K. Daud, "Energy Consumption Monitoring and Alert System via IoT," 2019 7th International Conference on Future Internet of Things and Cloud (FiCloud), Istanbul, Turkey, 2019, pp. 265-269.
- [10] Calculate Electricity Usage, EnergyUseCalculator. Accessed on: Jul 04, 2020. [Online]. Available: http://energyusecalculator.com/calculate_electrical_usage.htm
- [11] Calculate your power consumption, SaveOnEnergy. Accessed on: Jul 16, 2020. [Online]. Available: <https://www.saveonenergy.com/energy-resources/energy-consumption/>
- [12] Abhishek Jain (Mod), Online Electricity Bill Calculator – For all states in India, Jul 14, 2020. Accessed on: Jul 16, 2020. [Online]. Available: <https://www.bijlibachao.com/electricity-bill/online-electricity-bill-calculator-for-all-states-in-india.html>