



## Fuzzy logic controller based G2V & V2G Technologies for Three Phase Bi-directional Electric Vehicle Battery Charger

*1Siddanthi Abhilash, 2K.Giri Babu, 3J.Kartigeyan,*

*1M.Tech Student, 2Assistant Professor, 3Associate Professor,*

*Department of Electrical and Electronics Engineering,*

*J.B. Institute of Engineering and Technology, Hyderabad, Telangana – 500 075.*

### Abstract:

This paper presents the design and implementation of a Fuzzy Logic Controller (FLC)-based three-phase bi-directional electric vehicle (EV) battery charger integrating Grid-to-Vehicle (G2V) and Vehicle-to-Grid (V2G) technologies. The rapid growth in electric vehicle adoption necessitates efficient and intelligent charging systems that not only charge vehicle batteries but also facilitate energy exchange between the vehicle and the power grid. The proposed system leverages a Fuzzy Logic Controller to manage the charging and discharging processes, enhancing the system's adaptability to varying grid conditions and battery states.

The bi-directional charger supports three-phase power, enabling higher power transfer rates and improved efficiency. In G2V mode, the charger ensures optimal charging of the EV battery while minimizing stress on the power grid. Conversely, in V2G mode, the system allows the vehicle to return stored energy to the grid, supporting grid stability and providing ancillary services. Electric vehicle batteries and the grid can exchange electricity in both directions. Peak load cutting, load levelling, voltage regulation, and increased power system stability are made possible as a result. We created an OBC charger for (EVs), aiming to use technologies such as (V2G), (G2V), and (V2L). Using current i.e., sinusoidal and UPF in the grid-to-vehicle mode we can charge our batteries. The capacity to

return battery energy to the power grid during V2G system enhances the stability of the electrical system. In case of V2L system during power breakdowns or to power loads in remote areas that are not connected to the power grid. Simulation implementation of the proposed system demonstrate its effectiveness. The FLC-based charger shows superior performance in managing power flow compared to conventional controllers, with improvements in response time, stability, and energy efficiency. The results highlight the potential of integrating fuzzy logic control in bi-directional EV chargers to enhance the interaction between EVs and the power grid, contributing to the advancement of smart grid technologies.

**Keywords:** On Board charger (OBC); Electric vehicle (EV); Controlled Current Source (CCS); Total Harmonic Distortion (THD); Vehicle-to Load (V2L); Bidirectional battery charger (BBC); Bi-directional converter (BC); Transfer Function (TF)

### I.INTRODUCTION

#### 1.1 Background on Electric Vehicle (EV) Battery Chargers

Electric vehicles (EVs) have gained significant traction in recent years as a sustainable alternative to traditional internal combustion engine vehicles. One of the critical components of EV technology is the battery charger, which converts alternating current (AC) from the grid to direct current (DC) required by the EV battery. EV battery chargers can be classified



into different types based on their power levels, charging times, and functionalities. With advancements in technology, there is a growing demand for intelligent and efficient chargers that can handle high power levels, reduce charging times, and integrate seamlessly with the electrical grid. In the future, more electric vehicles will be used so that the issue of global pollution can be solved. It will be necessary to use charging facilities to replenish the EVs battery. In this configuration, the electric vehicle's battery will be charged, and the excess electric energy can be returned to the Grid. Global interest in the electrification of the transportation industry recently has increased as a possible solution to the aforementioned problems.

### 1.2 Importance of Bi-directional Charging

Bi-directional charging is a technology that allows the flow of electricity to be bidirectional, meaning that power can flow from the grid to the vehicle (G2V) and from the vehicle to the grid (V2G). This capability is crucial for several reasons:

- **Grid Stability:** EVs can serve as mobile energy storage units, helping to stabilize the grid by providing energy during peak demand or absorbing excess energy during low demand.
- **Renewable Energy Integration:** Bi-directional charging facilitates the integration of renewable energy sources by storing surplus energy generated from sources like solar and wind for later use.
- **Cost Savings:** Vehicle owners can potentially save on electricity costs by charging during off-peak hours and discharging during peak hours.
- **Emergency Power Supply:** EVs can provide power to homes or critical facilities during power outages.

There are two stages in a two-stage bidirectional battery charger. The first step (Buck converter) consists of an AC/DC converter that enables electricity to flow both ways from the grid to the internal DC link. If required, it is also maintained at unity power factor. The second step (the "Boost Converter"), which regulates the voltage and current of the battery, is made up of a DC/DC converter. Additionally, this setting enables the adjustment of reactive power. V2G is the term used to describe the flow of active electricity from the EV battery to the grid. Charging process of EVs batteries should be managed for maintaining a standard of power in the power grid in the G2V and V2G processes. However, when EVs become more common, a significant quantity of energy will be kept in the batteries of electric vehicle, creating the possibility of an energy flow in the other direction (Vehicle-to-Grid, V2G).

### 1.3 Overview of Fuzzy Logic Controllers

Fuzzy Logic Controllers (FLCs) are a form of artificial intelligence used to handle systems with uncertainties and nonlinearities. Unlike traditional controllers that rely on precise mathematical models, FLCs use a rule-based approach to make decisions based on fuzzy sets and linguistic variables. This makes them particularly suitable for applications where system behavior is complex and difficult to model accurately. Key advantages of FLCs include:

- **Robustness:** Ability to handle imprecise and noisy data.
- **Adaptability:** Can be easily tuned and modified to accommodate changes in system behavior.
- **Simplicity:** Easier to design and implement compared to traditional control methods for complex systems.



Considering fuzzy logic strategy, In addition EVs can be operated as a voltage source in G2V and V2G system and capable of supplying the electrical loads with EV charging stations. This technology is starting to be referred to as "vehicle-to-Load" in the literature (V2L) [5]. Therefore, the growth of the smart grid will begin with smart households equipped with energy management and efficiency technologies. On-board battery charger that is suggested in this study permits the V2L system in location at which Electric Vehicle is kept. This BBC enables to receive power from grid in the grid-to-vehicle operation and delivered back to grid from the energy stored in the battery in the vehicle-to-grid operation so that we can operate our EVs in the disconnected place, or also providing energy to loads connected to the EV in the form of Vehicle-to-Load operation. V2G uses the EV battery bank's stored energy to export power back to grid, & generating income. The G2V manner of battery charging is used, and the utility is responsible for meeting the parking area's energy needs. In this series of concepts, electric vehicles can benefit residential energy conservation, particularly to supply essential loads when blackouts and other emergencies occur. From the perspective of grid, electric vehicle can enhance auxiliary services and compensate for the intermittent nature of renewable energy sources [8].

## II. LITERATURE REVIEW

### 2.1 Existing EV Battery Charger Technologies

Electric vehicle (EV) battery chargers are crucial for the operation of EVs, and various technologies have been developed to meet the growing demand. Chargers can be categorized based on their power levels into Level 1 (slow charging), Level 2 (faster charging), and Level 3 or DC fast charging. Level 1 chargers use standard household outlets and provide low

power, suitable for overnight charging. Level 2 chargers, which require a dedicated 240V outlet, offer faster charging times and are commonly used in residential and commercial settings. Level 3 chargers, also known as DC fast chargers, can recharge an EV battery to 80% in 20-30 minutes, making them ideal for public charging stations and long-distance travel.

### 2.2 Bi-directional Charging Systems

Bi-directional charging technology enables power flow in both directions: from the grid to the vehicle (G2V) and from the vehicle to the grid (V2G). This technology is essential for smart grid applications, allowing EVs to act as distributed energy storage systems. Research in bi-directional chargers has focused on improving efficiency, reducing costs, and enhancing grid integration. Key studies have explored the potential benefits of V2G technology, such as grid stabilization, renewable energy integration, and cost savings for consumers. Several pilot projects worldwide have demonstrated the feasibility of V2G systems, showcasing their potential to support grid reliability and renewable energy deployment.

### 2.3 Grid-to-Vehicle (G2V) and Vehicle-to-Grid (V2G) Technologies

G2V and V2G technologies represent two fundamental aspects of bi-directional charging. G2V focuses on charging the EV battery from the grid, optimizing the process to reduce charging times and improve efficiency. V2G, on the other hand, involves discharging the stored energy from the EV battery back to the grid. Research in this area has highlighted several key benefits:

- **Grid Stability:** EVs can provide ancillary services such as frequency regulation and load balancing.

- **Renewable Energy Integration:** EVs can store excess energy generated from renewable sources and supply it back to the grid when needed.
- **Economic Benefits:** Vehicle owners can participate in energy markets, selling stored energy during peak demand periods. Challenges in implementing G2V and V2G technologies include the need for standardized communication protocols, battery degradation concerns, and regulatory barriers.

## 2.4 Fuzzy Logic Controllers in Power Electronics

Fuzzy Logic Controllers (FLCs) have been widely adopted in power electronics due to their ability to handle uncertainties and nonlinearities in system behavior. FLCs use a set of linguistic rules and membership functions to make decisions based on imprecise input data. This approach is particularly useful in applications where system dynamics are complex and difficult to model accurately. Key advantages of FLCs include robustness, adaptability, and simplicity in design and implementation.

In the context of EV battery chargers, FLCs have been used to optimize charging processes, improve power quality, and enhance system stability. Several studies have demonstrated the effectiveness of FLCs in managing power flow in bi-directional charging systems. For example, FLCs have been applied to control the charging and discharging cycles, ensuring efficient energy transfer and minimizing battery degradation. The flexibility of FLCs allows them to be easily integrated with other control strategies, such as Model Predictive Control (MPC) and Proportional-Integral-Derivative (PID) control, to achieve superior performance.

## III. DESIGN AND CONTROL

## COMPONENTS OF BI-DIRECTIONAL BATTERY CHARGER

DC bus is present in between the converters on each side which make up the battery charger that is being displayed. One will connect to the electrical grid, while the other will connect to the traction batteries. in chronological order. A FB AC-DC BC is used to communicate with the power grid. ACDC Bidirectional converter can act active rectifier with sinusoidal current and UPF in the Grid-to-vehicle system.

This AC-DC converter performs the function of an inverter in case of V2G and V2L. The converter functions as a CCS in the V2G mode to feed the necessary power into the grid. In the vehicle-to-load case FB AC-DC converter acts as source of voltage, supplying the household loads. To link the batteries a DC/DC converter is used. In the grid-to-vehicle mode of bidirectional DC/DC converter behave as a buck converter for maintaining the current and voltage stages of the charging cycle throughout in the batteries. The DC/DC functions as a boost converter during V2G and V2H to raise the battery voltage to a suitable DC bus voltage in BBC. In Fig.1 displays the bidirectional battery charger's full electric schematic [1]. The whole architecture is similar hardware is comparable with a controlled Full bridge even though it uses two bidirectional converters. Fig.1 shows the basic layout of BBC topology [2].

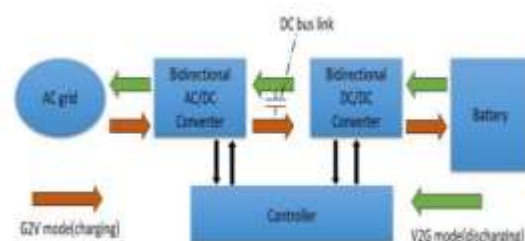
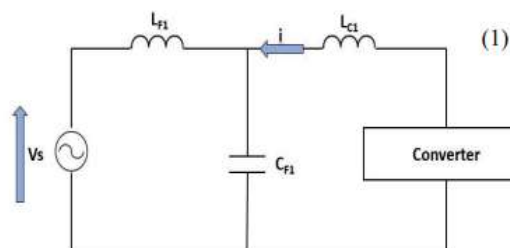

Fig.1 Structure of Bi-directional battery charger topology

### A. LCL FILTER



The LCL filter, which is seen in Fig. 2, is used to reduce ripple at the grid side in order to obtain low THD at the grid side. The grid side filter's single-phase circuit is depicted in Fig. 2 [2]. While preserving the stability of the entire system, the values of the filter's elements must be selected. Because of this, the transfer function of the filter is established [2]:



### B. AC-DC BI-DIRECTIONAL CONVERTER

Depending on the operating mode, a power electronics circuit known as an AC-DC bi-directional converter can convert alternating current (AC) power to direct current (DC) power or vice versa. The converter can serve as a rectifier in one mode, converting AC power to DC power. In this mode, a diode bridge rectifier and a filter capacitor are commonly used to convert the AC voltage to a high DC voltage. Different electrical devices can then be powered by the resulting DC voltage. Broad output voltage buck-boost converters for unidirectional applications can lower the THD of AC current [4]. The converter can also operate as an inverter in the other mode, converting DC power to AC power. In this manner, a switching circuit is often used to convert the DC voltage to a high-frequency AC voltage, which is subsequently transformed by a transformer to the appropriate voltage level. [8]. Hence the converter is used where the capacity to both charge and discharge a battery is required.

### C. DC/DC CONVERTER TOPOLOGIES

DC-DC Converter is used to transform a DC signal with a given voltage into another DC

signal with a different voltage. In order to increase battery life, it is frequently utilized in constant voltage and constant current application in case of charging & discharging of car battery [3]. Moreover, it uses transformers to create isolation between both the sides, and it also controls output voltage by applying a control signal to it. The non-isolated topologies change the DC voltage from one level to another level without using a transformer to provide galvanic isolation between the circuits [9]. As a result, these topologies lack benefits such as isolation between the source and the load and high step-up voltage gain ratio. Yet, because no transformer is used and the system will be small without one, their weights are lowered. Reactive power is generated in supply lines when transformers and converters are utilized, hence greater compensation is needed. Transformers cannot handle high current because when they are employed at high frequencies, both the transformer & its coil size are decreased [9]. Moreover, the employment of a transformer with a converter might result in conductor core loss and skin effect.

#### Buck-Boost-derived bi-directional DC-DC converter

The single directional buck/boost converter's basic structure is modified by adding one additional switch to create the buck-boost DC-DC converter topology [9]. It transfers power in each side as usual with the exception that the polarity of voltage at load side & the input side are of different sign.

#### Dual Active bi-directional DC-DC Converter

This topology is composed of full-bridge and half-bridge circuits that are already in use and are powered by voltage or current. The converter's use of number of switches will proportionally affect how much power is transferred. Low loss semiconductor switches can be used to alleviate the problem of



switching losses caused by using additional switches in the topology [9]. Due to the involvement of two bridges, one is on the primary side and the other is on the secondary side. To function each bridge, complementary switching signals are provided to each bridge. Since this topology includes a greater number of switching elements, soft switching phenomenon can be simply utilised to reduce total switching losses. The control logic is made simpler by digital control because the circuit is complex. Controllable energy transfer is possible from the input side to the output side. The efficiency of these converters can be improved by utilizing effective control approaches. The converter's first stage can convert DC signals into AC signals using either current- or voltage-fed-based control [9]. By employing a transformer in the second stage of the converter to step-up the voltage level and a resonant tank circuit with a transformer to obtain ZVS/ZCS, this system with the transformer is made to operate with a high degree of efficiency. In the converter's third stage, a full-bridge AC - DC converter transforms the AC signal provided from the transformer into a DC signal using control signal [9].

### Design of the Fuzzy Logic Controller

The Fuzzy Logic Controller is designed to manage the bi-directional power flow efficiently. The design process involves the following steps:

**Input Variables:** Define input variables for the FLC, such as grid power demand, battery SOC, and battery SOH.

**Fuzzy Sets and Membership Functions:** Create fuzzy sets and membership functions for each input variable. For example, battery SOC can be categorized as Low, Medium, and High.

**Fuzzy Rules:** Develop a set of fuzzy rules that govern the behavior of the system. These rules are based on expert knowledge and are

designed to achieve optimal charging and discharging.

**Inference Engine:** Implement the inference engine to process the fuzzy rules and determine the output actions, such as adjusting the charging current or switching between G2V and V2G modes.

**Defuzzification:** Convert the fuzzy output to a precise control action that can be applied to the power electronics.

### 3.3 Three-Phase Bi-directional Charger Design

The bi-directional charger design includes both hardware and software components to handle the conversion between AC and DC power:

**Fuzzy Logic Controller:** Integrate the FLC to optimize the charging and discharging processes.

## CONTROL BLOCK DIAGRAM & TOPOLOGY CIRCUIT

**Three Phase Bi-directional Battery Charger:** In this the basic model of a three-phase EV battery charger shown in fig.5. To control the battery current during charging and discharging operations, a bi-directional buck/boost converter is used in the input. This device is also referred to as an active rectifier and converts the ac grid voltage to direct current voltage while also maintaining a constant voltage across the dc bus. And the specifications of the complete system are as grid voltage is 415V phase-to-phase at 50 Hz, filter inductance is 5mH & capacitance is 30 $\mu$ F. In the inverter bridge we used IGBT and value of bus capacitance is 5600 $\mu$ F, mosfet is used in buck converter & buck filter inductance is 20mH, output capacitance is 0.625 $\mu$ F. Battery nominal voltage is 360V, switching frequency of both the converter is 10kHz. Total rated power is 10kW.

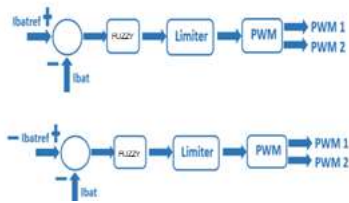

Fig.4 Control system for battery discharging

Three Phase Bi-directional Battery Charger  
G2V & V2G Mode of Operation:

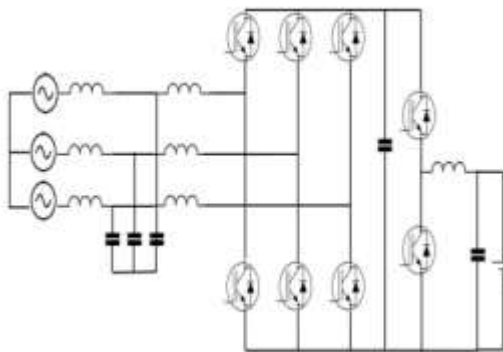

Fig.5 Circuit diagram of three phase bi-directional battery charger

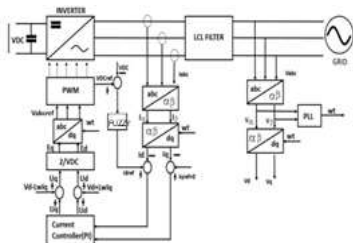

Fig.6 Block diagram of Active rectifier controller

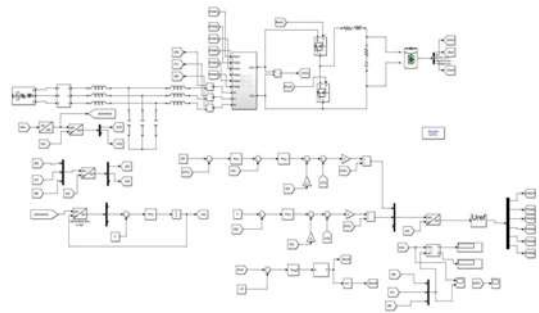

Fig.7 Simulink model of three phase bi-directional battery charger with G2V and V2G mode operation

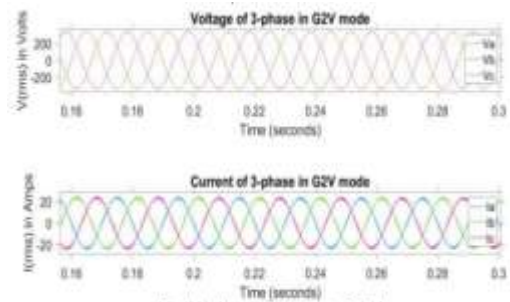

Fig.8 Voltage and current of Grid

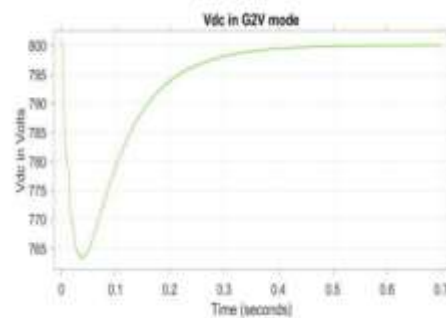

Fig.9 DC bus voltage

**IV.SIMULATION RESULTS:**

Three Phase Bi-directional Battery Charger:

**A. Grid-to-vehicle system:**

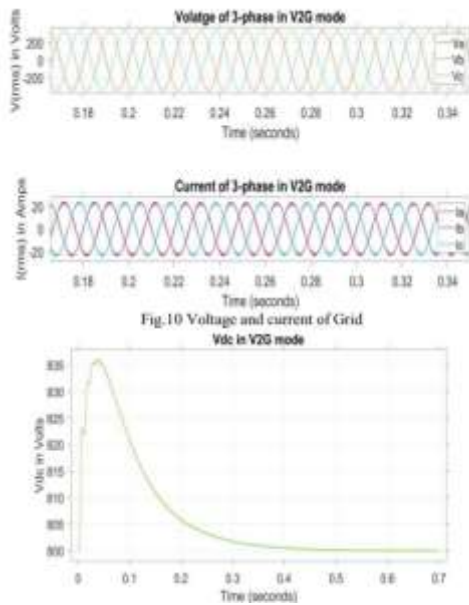

Fig.11 DC bus voltage

**V.CONCLUSION:**

This research presents a comprehensive study on the development and implementation of a Fuzzy Logic Controller (FLC)-based three-phase bi-directional electric vehicle (EV) battery charger, integrating both Grid-to-Vehicle (G2V) and Vehicle-to-Grid (V2G) technologies. The designed system aims to address the growing demand for intelligent and efficient charging solutions that can enhance the interaction between EVs and the power grid. The ability for electricity to flow both into and out of electric vehicles (EVs) has only recently progressed to the point where more people can use it. The technology's promise will increase as it develops. Going bidirectional has a number of benefits, including the ability to increase revenue by reselling energy to the grid and achieve energy independence. This study describes the creation of an OBC for (EVs) that can function in (G2V) and (V2G) & V2L modes, which are key tools aimed at the future of smart grids. The presented battery charger's topologies are verified using the MATLAB program. Two types of topologies— two-stage and singlestage—are separated. Comparisons are

made between both the types of ac-dc bi-directional converter in terms of component count, values of elements present in both the converter.

**REFERENCES:**

[1] J. G. Pinto et al., "Bidirectional battery charger with Grid-to-Vehicle, Vehicle-to-Grid and Vehicle-to-Home technologies," IECON 2013 - 39th Annual Conference of the IEEE Industrial Electronics Society, Vienna, Austria, 2013, pp. 5934-5939, doi: 10.1109/IECON.2013.6700108

[2] R. Zgheib, K. Al-Haddad and I. Kamwa, "V2G, G2V and active filter operation of a bidirectional battery charger for electric vehicles," 2016 IEEE International Conference on Industrial Technology (ICIT), Taipei, Taiwan, 2016, pp. 1260-1265, doi: 10.1109/ICIT.2016.7474935.

[3] Chakraborty, S., Vu, H.N., Hasan, M.M., Tran, D.D., Baghdadi, M.E. and Hegazy, O., 2019. DC-DC converter topologies for electric vehicles, plug-in hybrid electric vehicles and fast charging stations: State of the art and future trends. *Energies*, 12(8), p.1569.

[4] B. Koushki, A. Safaee, P. Jain and A. Bakhshai, "Review and comparison of bi-directional AC-DC converters with V2G capability for on-board EV and HEV," 2014 IEEE Transportation Electrification Conference and Expo (ITEC), Dearborn, MI, USA, 2014, pp. 1-6, doi: 10.1109/ITEC.2014.6861779.

[5] V. K, R. K. Nema and A. Ojha, "Various Types of Wireless Battery Management System in Ev," 2020 IEEE International Students' Conference on Electrical, Electronics and Computer Science (SCEECS), Bhopal, India, 2020, pp. 1-5, doi: 10.1109/SCEECS48394.2020.115.

[6] Kumar, M., Ojha, A. (2022). Design Consideration for e-Rikshaw with Regeneration Capability. In: Verma, P., Samuel,





O.D., Verma, T.N., Dwivedi, G. (eds)  
Advancement in Materials, Manufacturing and  
Energy Engineering, Vol. I. Lecture Notes in  
Mechanical Engineering. Springer, Singapore.  
[https://doi.org/10.1007/978-981-16-5371-1\\_15](https://doi.org/10.1007/978-981-16-5371-1_15).

[7] Kumar, M. and Ojha, A., 2019. Key developments for electric vehicles in local transport. *J Instrum Inno Sci*, 4(2), pp.36-45..

[8] Ojha, A., Chaturvedi, P., Mittal, A. and Jain, S., 2016. Carrier based common mode voltage reduction techniques in neutral point clamped inverter-based AC-DC-AC drive system. *Journal of Power Electronics*, 16(1), pp.142-152.

[9] Viswanatha, V., Ramachandra, A.C. & Venkata Siva Reddy, R. RETRACTED ARTICLE: Bidirectional DC-DC converter circuits and smart control algorithms: a review. *Journal of Electrical Systems and Inf Technol* 9, 6 (2022). <https://doi.org/10.1186/s43067-022-00048-z>