



STUDY ON AUTOMATIC PNEUMATIC BUMPER

Sanjay Kumar Mavi, Lecturer, Department of Mechanical Engineering (Maintenance), IIMT College of Polytechnic, Greater Noida, UP, India

Jugendra Singh, Lecturer, Department of Mechanical Engineering (Production), IIMT College of Polytechnic, Greater Noida, UP, India

Banty Kumar, Lecturer, Department of Mechanical Engineering (Production), IIMT College of Polytechnic, Greater Noida, UP, India

Abstract:

The technology of pneumatics is used in the field of workplace restructuring of an organization to improve efficiency, automation, modern machine shops, automobiles, space robotics etc. It is therefore important that technicians and engineers should have a good knowledge of pneumatic system, air operated valves and accessories.

A control system which is based on intelligent an electronically controlled automotive bumper activation system is called “automatic pneumatic bumper”. This system consists of IR transmitter and Receiver circuit, Control Unit, Pneumatic bumper system. The IR sensor is used to detect the obstacle. There is any obstacle closer to the vehicle (within 4 feet), the control signal is given to the bumper activation system.

The pneumatic bumper system is used to protect the man and vehicle. This bumper activation system is only activated the vehicle speed above 45-55 km per hour. This vehicle speed is sensed by the proximity sensor and this signal is given to the control unit and pneumatic bumper activation system.

Keywords: Pneumatic Bumper, IR sensor, Bumper Activation System.

Introduction:

An automatic pneumatic bumper is fully equipped by IR sensors circuit and Pneumatic bumper activation circuit. It is fully equipped and designed for Automobile vehicles. This forms an integral part of best quality. This product underwent strenuous test in our Automobile vehicles and it is good.

1.1 Need For Automation:

Automation can be achieved through computers, hydraulics, pneumatics, robotics, etc., of these sources, pneumatics form an attractive medium for low cost automation. The main advantages of all pneumatic systems are economy and simplicity. Automation plays an important role in mass production.

For mass production of the product, the machining operations decide the sequence of machining. The machines designed for producing a particular product are called transfer machines. The components must be moved automatically from the bins to various machines sequentially and the final component can be placed separately for packaging. Materials can also be repeatedly transferred from the moving conveyors to the work place and vice versa.

Nowadays almost all the manufacturing process is being automated in order to deliver the products at a faster rate. The manufacturing operation is being automated for the following reasons:

- To achieve mass production
- To reduce man power
- To increase the efficiency of the plant
- To reduce the work load
- To reduce the production cost
- To reduce the production time
- To reduce the material handling
- To reduce the fatigue of workers

- To achieve good product quality

BLOCK DIAGRAM

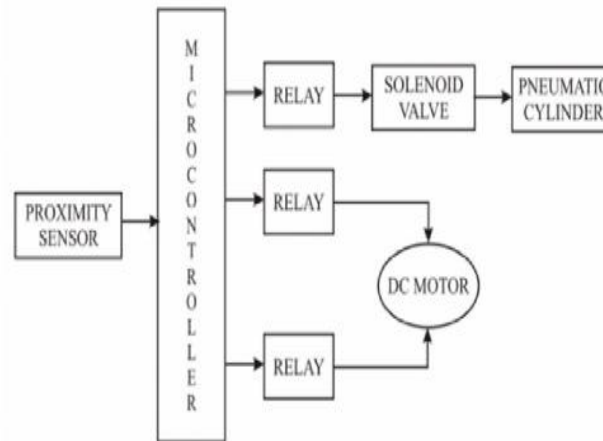

Pneumatics:

The word ‘pneuma’ comes from Greek and means breather wind. The word pneumatics is the study of air movement and its phenomena is derived from the word pneuma. Today pneumatics is mainly understood to means the application of air as a working medium in industry especially the driving and controlling of machines and equipment.

Pneumatics has for some considerable time between used for carrying out the simplest mechanical tasks in more recent times has played a more important role in the development of pneumatic technology for automation.

Pneumatic systems operate on a supply of compressed air which must be made available in sufficient quantity and at a pressure to suit the capacity of the system. When the pneumatic system is being adopted for the first time, however it will indeed the necessary to deal with the question of compressed air supply.

The key part of any facility for supply of compressed air is by means using reciprocating compressor. A compressor is a machine that takes in air, gas at a certain pressure and delivered the air at a high pressure.

Compressor capacity is the actual quantity of air compressed and delivered and the volume expressed is that of the air at intake conditions namely at atmosphere pressure and normal ambient temperature. The compressibility of the air was first investigated by Robert Boyle in 1662 and that found that the product of pressure and volume of a particular quantity of gas.(1)

Which is written as:

$$PV = C \quad (\text{or}) \quad P_1V_1 = P_2V_2$$

In this equation the pressure is the absolute pressured which for free is about 14.7 psi and is of courage capable of maintaining a column of mercury, nearly 30 inches high in an ordinary barometer. Any gas can be used in pneumatic system but air is the mostly used system now a days.

Types of Braking:

The brakes for automotive use may be classified according the following Considerations.

1. Purpose
2. Location
3. Construction
4. Method of Actuation
4. Extra Braking Effort



Based on the above considerations, brakes are classified with respect to following factors

With respect to application,

- a. Foot brake
- b. Hand brake

With respect to the number of wheels,

- c. Two wheel brakes
- d. Four wheel brakes

With respect to the method of braking contact

- e. Internal expanding brakes
- f. External contracting brakes

With respect to the method of applying the braking force.

- g. Single acting brake
- h. Double acting brakes.

With respect to the brake gear,

- i. Mechanical brake
- j. Power brakes

With respect to the nature of power employed

- k. Vacuum brake
- l. Air brake
- m. Hydraulic brake
- n. Hydrostatic brake
- o. Electric brake

With respect to power transmission,

- p. Direct acting brakes
- q. Geared brakes

With respect to power unit,

- r. Cylinder brakes
- s. Diaphragm brake

The foot brake or service brake is always applied by a pedal, while the parking brake is applied by a hand lever. The parking brake is intended chiefly to hold the car in position. The parking brake can be set in the "ON" position by means of a latch while the service brake remains on only as long as the driver presses down on the pedal.(2)

The hand brake is normally used only after the driver has stopped the car by using the foot brake. Its other use is as an emergency brake to stop the car if the foot braking system should fail. The hand or parking brakes operates on a pair of wheels, frequently the rear wheels. When drum type rear brakes are used, the same shoes can be used for both hand and foot control.(3)

The drum type of brake may either be a band brake or a shoe brake. Both band brakes and shoe brakes may be either external or internal. The band brakes generally are external and shoe brakes internal. In drum brakes the drum is attached to the wheel and revolves with it. Friction to slow the drum is applied from inside by the shoes which do not rotate but are mounted on a stationary metal back plate. There are different types of drum brakes such as a two leading shoe arrangement – which gives an augmented response to pedal effort because of its self applying arrangement. A leading-trailing shoe is a cheaper and better alternative as it is equally effective whether the car is going forward or backwards.

Manufacturers design drum brakes so that water or ice or grit cannot get inside and decrease braking efficiency for moisture greatly reduces the friction between the linings and the drum.

The dissipate quickly the considerable amount of heat generated when braking a fast moving heavy car large brake drums would be required. Disc brakes do the job more efficiently, for the cooling air

can get to the rubbing between each piston and the disc, there is a friction pad held in position by retaining pins, spring plates etc. Passages are drilled in the caliper for the fluid to enter or leave the each housing. These passages are also connected to another one for bleeding. Each cylinder contains a rubber selling ring between the cylinder and the piston.(4)

3.1 Mechanical Brake:

In a motor vehicle, the wheel is attached to an auxiliary wheel called drum. The brake shoes are made to contact this drum. In most designs, two shoes are used with each drum to form a complete brake mechanism at each wheel. The brake shoes have brake linings on their outer surfaces. Each brake shoe is hinged at one end by on anchor pin; the other end is operated by some means so that the brake shoe expands outwards. The brake linings come into contact with the drum. Retracting spring keeps the brake shoe into position when the brakes are not applied. The drumencloses the entire mechanism to keep out dust and moisture. The wheel attaching bolts on the drum are used to contact wheel and drum. The braking plate completes the brake enclosure, holds the assembly to car axle, and acts the base for fastening the brake shoes and operating mechanism. The shoes are generally mounted to rub against the inside surface of the drum to form as internal expanding brake

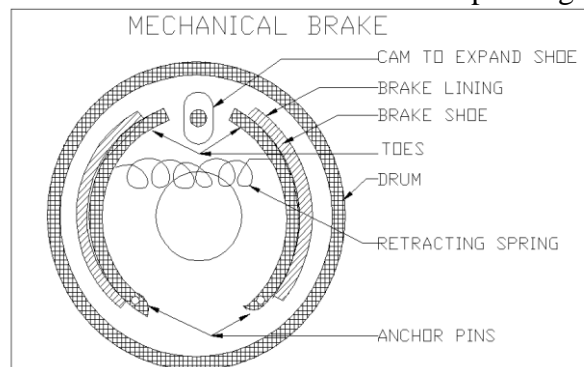

as shown in the figure

3.2 Hydraulic Brakes:

The hydraulic brakes are applied by the liquid pressure. The pedal force is transmitted to the brake shoe by means of a confined liquid through a system of force transmission.

The force applied to the pedal is multiplied and transmitted to brake shoes by a force transmission system. This system is based upon Pascal’s principle, which states that “The confined liquids transmit pressure without loss equally in all directions”.

It essentially consists of two main components: master cylinder and wheel cylinder the master cylinder is connected by the wheel cylinders at each of the four wheels. The system is filled with the liquid under light pressure when the brakes are not in operation. (5) The liquid is known as brake fluid, and is usually a mixture of glycerin and alcohol or caster-oil, denatured alcohol and some additives Spring pressure, and thus the fluid pressure in the entire system drops to its original low valve, which allows retracting spring on wheel brakes to pull the brake shoes out of contact with the brake drums into their original positions. This causes the wheel cylinder piston also to come back to its original inward position. Thus, the brakes are released.

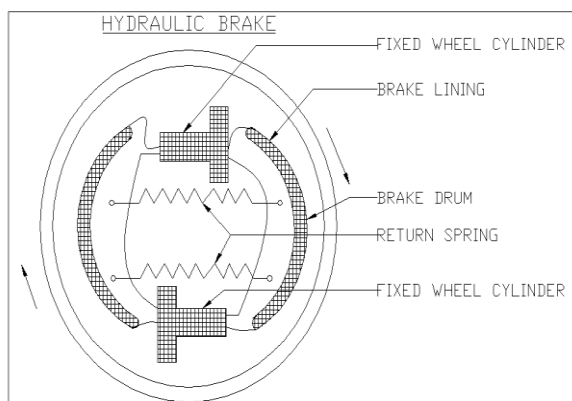

Drawing For Automatic Pneumatic Bumper for Four Wheeler:

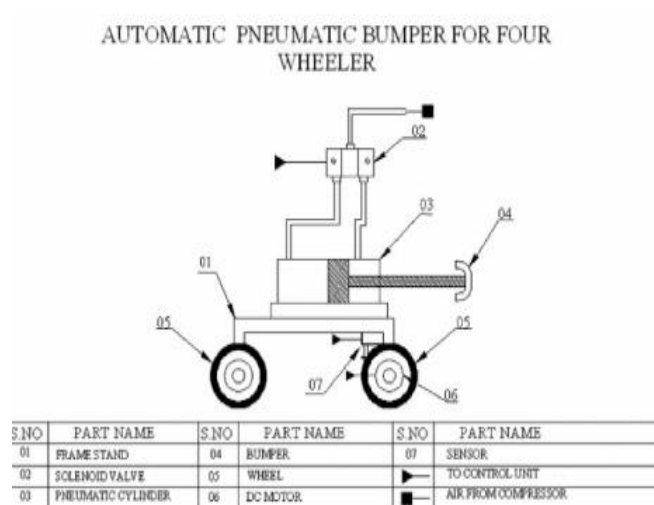

Conclusions:

The project work in institutes is a good solution to bridge the gap between institutions and industries. It helps to gain a lot of practical knowledge regarding, planning, purchasing, assembling and machining while doing the project work.(5)

The efforts are made to maintain tolerances and quality making maximum use of available facilities. The development of this “*pneumatic bumper for fourwheeler*” helps to know how to achieve low cost automation. The application of pneumatics produces smooth operation. By using more techniques, they can be modified and developed according to the applications.

References

1. G.B.S. Narang, “Automobile Engineering”, Khanna Publishers, Delhi, 1991, pp 671.
2. William H. Crowse, “Automobile Engineering”.
3. Donald. L. Anglin, “Automobile Engineering”.
4. Pneumatic Control System---Stroll &Bernaud, Tata McGraw Hill Publications, 1999.
5. Pneumatic System-Majumdhara, New Age India International (P) Ltd Publishers, 1997.