



## **HYBRID RENEWABLE ENERGY GENERATION SYSTEM USING SOLAR, WIND, AND TIDAL ENERGY**

**Mr. Avinash Vinod Satpute**, PG Student, Dept. Mechanical Engineering, Government College of Engineering Chandrapur

**Dr. L. P. Dhole**, Associate Professor, Dept. Mechanical Engineering, Government College of Engineering Chandrapur

**Dr. P. V. Chilbule**, Assistant Professor Dept. Mechanical Engineering, Government College of Engineering Chandrapur

**Dr. G. R. Chavhan**, Assistant Professor Dept. Mechanical Engineering, Government College of Engineering Chandrapur

### **ABSTRACT**

The increasing global demand for electricity and the environmental impact of conventional energy resources have encouraged the development of sustainable power generation technologies. Conventional energy sources such as coal, petroleum, and natural gas contribute significantly to air pollution and global warming. To address these challenges, renewable energy systems have become an important alternative for clean and sustainable electricity generation. This project proposes a hybrid renewable energy generation system that integrates solar, wind, and tidal energy sources to provide reliable and eco-friendly power generation. The combination of multiple renewable resources improves energy availability, reduces dependence on fossil fuels, and increases system reliability. The proposed system is particularly suitable for coastal regions, remote locations, islands, resorts, and industrial applications where continuous power supply is essential. The implementation of this hybrid system can reduce environmental pollution, lower operational costs, and promote green technology for sustainable development.

**Keywords:** Marine renewable energy, wind energy, Hybrid Wave energy, wind turbine. Solar, wind, tidal

### **I. Introduction**

Renewable energy has emerged as one of the most effective solutions to meet the growing energy demand while reducing environmental degradation. Traditional power generation methods mainly rely on fossil fuels, which are limited in availability and harmful to the environment. The combustion of fossil fuels releases greenhouse gases such as carbon dioxide and sulfur dioxide, contributing to climate change and air pollution. In addition, centralized power generation systems require extensive transmission infrastructure, making electricity supply difficult in remote and rural areas.

India possesses abundant renewable energy resources, including solar radiation, wind energy, and tidal energy along its coastal regions. The integration of these resources into a hybrid renewable energy system can improve power generation efficiency and reliability. Solar energy is available during daytime, wind energy can be utilized during varying atmospheric conditions, and tidal energy offers predictable power generation in coastal regions. Combining these energy sources helps maintain a continuous power supply even when one resource becomes temporarily unavailable.

Distributed generation systems based on renewable energy are simpler, cost-effective, and more suitable for isolated regions compared to conventional centralized generation systems. Therefore, the proposed hybrid renewable energy generation system aims to provide a sustainable, environmentally friendly, and reliable solution for future energy requirements..



## II. Literature

Several researchers have studied hybrid renewable energy systems to improve power generation efficiency and reliability. P. P. Shirsath et al. presented a solar-wind hybrid energy generation model that demonstrated the benefits of combining renewable resources for continuous power supply. Geetha Udyakanthi proposed the design of a wind-solar hybrid power generation system in Sri Lanka and highlighted the importance of renewable energy integration for reducing dependence on conventional fuels.

Anil Kumara Vadakkepurakkal investigated hybrid power generation using solar and wind energy and emphasized the role of hybrid systems in improving energy reliability. Researchers such as Halasa and Asumadu discussed the design and performance analysis of wind-solar hybrid electrical systems for efficient energy utilization.

Recent studies have also focused on the utilization of tidal energy for coastal power generation. Since India is surrounded by water on three sides, tidal energy offers significant potential for renewable electricity generation. The integration of tidal energy with solar and wind systems can improve energy availability and provide stable power generation throughout different environmental conditions.

Recent advancements in hybrid renewable energy systems have focused on improving the efficiency and reliability of integrated power generation models. Researchers have explored the combination of solar photovoltaic systems with wind turbines and tidal energy converters to ensure continuous energy availability under varying environmental conditions. The hybrid approach reduces the limitations associated with individual renewable energy sources and enhances overall system performance.

Energy storage technologies have also become an important area of research in hybrid renewable energy systems. Batteries, supercapacitors, and smart energy management systems are being integrated with renewable power generation units to store excess energy during peak production periods. These storage systems improve power stability and help maintain uninterrupted electricity supply during low generation periods caused by weather fluctuations or changing tidal conditions.

Several studies have highlighted the economic and environmental benefits of hybrid renewable energy systems. Researchers have reported that hybrid systems significantly reduce greenhouse gas emissions and dependence on fossil fuels compared to conventional energy generation methods. In coastal regions, the integration of tidal energy with solar and wind power has shown promising results for supplying electricity to isolated communities, marine industries, and offshore facilities.

Modern control and monitoring techniques such as IoT-based monitoring, artificial intelligence, and automated energy management systems are increasingly being applied in hybrid renewable energy projects. These technologies help optimize energy generation, monitor system performance in real time, and improve fault detection capabilities. As a result, hybrid renewable energy systems are becoming more reliable, efficient, and suitable for large-scale implementation in future smart grid applications.

## III. Objectives

- To maximize overall power generation by integrating solar, wind, and tidal energy resources.
- To improve system reliability through hybrid energy generation.
- To reduce dependence on conventional fossil fuel-based power generation.
- To integrate energy storage systems for efficient utilization of generated energy.
- To minimize environmental pollution and support sustainable development.



- To provide reliable electricity supply for coastal and remote areas.

#### **IV. Problem Identification**

Conventional power generation systems are associated with several challenges, including environmental pollution, depletion of fossil fuel reserves, and high transmission costs. Fossil fuels such as coal, diesel, and natural gas emit harmful gases including carbon dioxide, nitrogen oxides, sulfur dioxide, and carbon monoxide, which negatively affect human health and the environment. In addition, nuclear power generation involves radioactive materials that may pose serious environmental and health risks if not properly managed. Many rural and remote regions still face difficulties in accessing reliable electricity due to the limitations of centralized power distribution systems. Long transmission lines increase power losses and infrastructure costs. Therefore, there is a growing need for decentralized renewable energy systems capable of delivering sustainable and uninterrupted power supply. The proposed hybrid renewable energy system addresses these challenges by combining solar, wind, and tidal energy sources to create a cleaner, s

#### **V. Proposed System**

It operates efficiently because it utilizes multiple renewable energy sources that complement one another. During the daytime, the solar panel provides the primary source of power, while during windy or cloudy conditions, the wind turbine ensures continued power generation. Additionally, the tidal energy system produces power consistently based on the predictable movement of tides, thus compensating for periods when both solar and wind power might be insufficient. This combination provides a continuous and balanced supply of energy throughout the day and across different seasons. It demonstrates how integrating multiple renewable energy technologies can overcome the limitations of individual sources, provide continuous power, and reduce dependency on non-renewable energy. The system also promotes environmental protection by minimizing carbon emissions and supports the vision of green and renewable energy utilization for future applications.

#### **VI. Methodology and Working**

The working principle of the hybrid renewable energy system integrating tidal, solar, and wind energy sources with a charging circuit, battery, and LED load is based on the combined operation of multiple energy conversion and power conditioning processes to achieve efficient and continuous electricity generation. In this system, the solar photovoltaic (PV) module converts solar irradiance into direct current (DC) electrical energy using the photovoltaic effect, where incident photons excite electrons within the semiconductor material, producing a potential difference. The wind turbine generator (WTG) converts the kinetic energy of moving air into rotational mechanical energy, which drives a generator—commonly a permanent magnet synchronous generator (PMSG) or DC generator—to produce electrical power. Simultaneously, the tidal energy conversion unit harnesses the hydro-kinetic energy of ocean tides; the flow of water during high and low tides rotates submerged turbine blades mechanically coupled to a generator, resulting in DC power output. The electrical outputs from these three renewable sources are directed to a power conditioning and charging circuit, which performs rectification, voltage regulation, current control, and load balancing. This circuit ensures proper DC bus stabilization, maintains constant voltage levels, and prevents backflow of current to the generators through blocking diodes or charge controllers. The energy storage subsystem, typically a lithium-ion or lead-acid battery, stores excess energy during peak generation periods and supplies power during low generation intervals, ensuring system reliability and continuous operation.

The charging circuit continuously monitors the state of charge (SOC) and state of health (SOH) of the battery to avoid overcharging and deep discharging conditions. The stored DC power is

then supplied to the LED (Light Emitting Diode) load, which operates on the electroluminescence principle, converting electrical energy directly into visible light with high luminous efficacy and low thermal losses. The hybrid operation ensures maximum power point utilization (MPPT), energy stability, and power quality enhancement by compensating for the intermittency of individual renewable sources. This integrated system provides a sustainable, efficient, and reliable power generation solution suitable for both standalone and grid-assisted applications

### VII. Conceptual Diagram

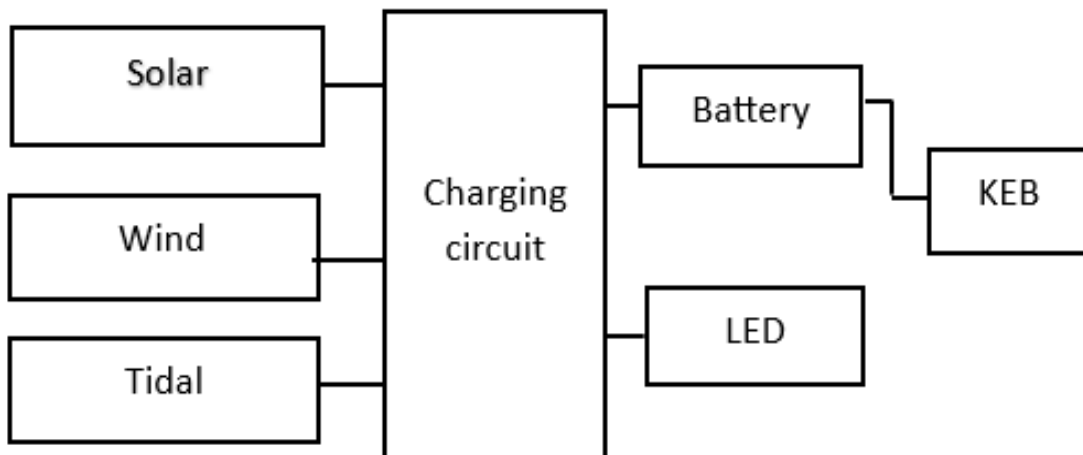
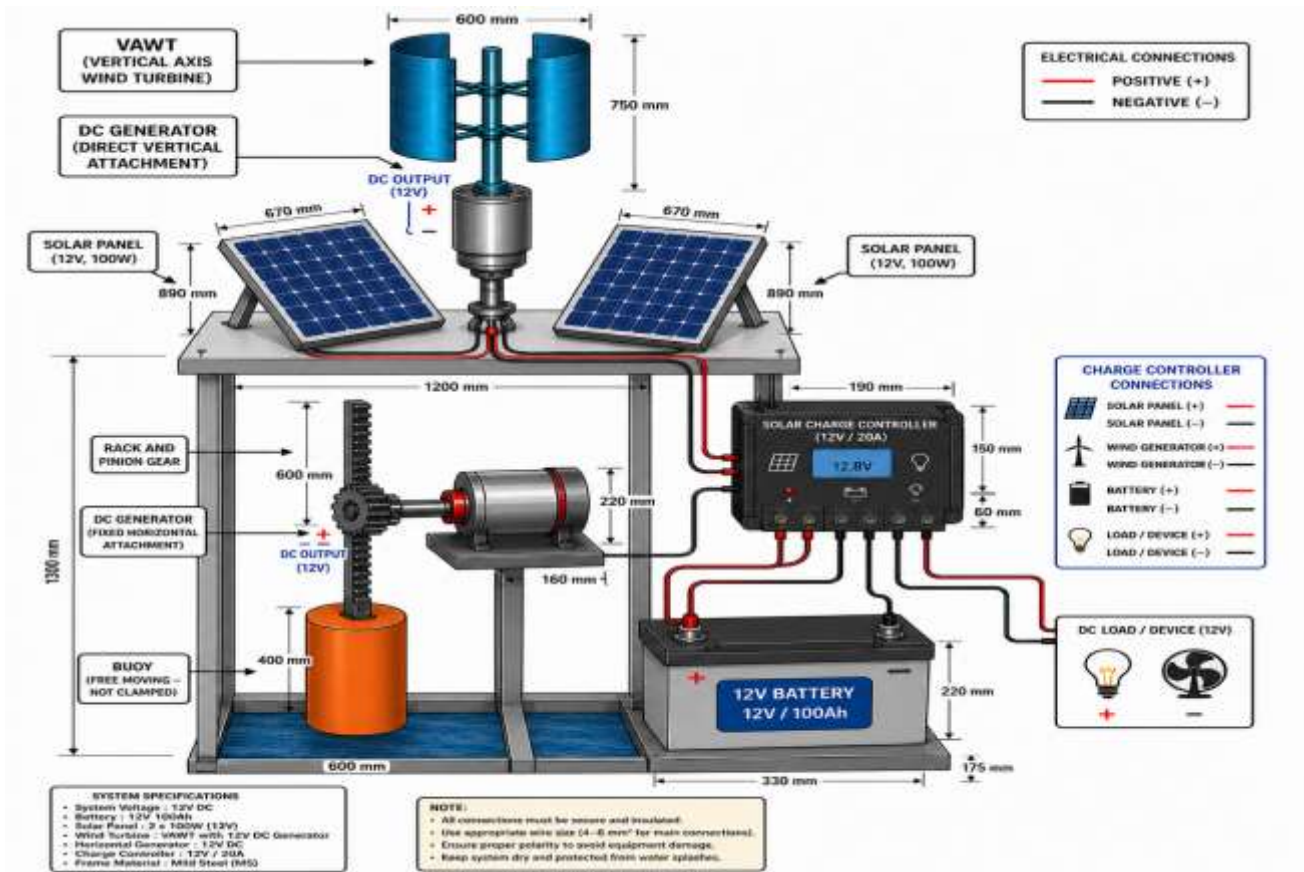

**VIII. Advantages of Proposed System**

- Reduction in environmental pollution and greenhouse gas emissions.
- Efficient utilization of multiple renewable energy resources.
- Lower operating and maintenance costs compared to conventional systems.
- Reliable and continuous power generation.
- Suitable for remote and coastal areas.
- Support for sustainable and green energy development.

**IX. Result**

Output Power Generation Voltage

Time	V (V)	I (A)	W (W)	T (°C)
7:30 am	3.19	0.09	0.2871	27.5
8:00 am	4.65	0.15	0.6975	27.8
8:30 am	9.45	0.29	2.7405	30.8
9:00 am	12.13	0.44	5.3372	34.7
9:30 am	15.35	0.45	6.9075	38.9
10:00 am	16.52	0.53	8.7556	41.4
10:30 am	17.04	0.58	9.8832	44.4
11:00 am	17.35	0.58	10.0630	45.4
11:30 am	17.42	0.58	10.1036	46.8
12:00 pm	17.43	0.58	10.1094	47.8
12:30 pm	17.49	0.58	10.1442	49.5
1:00 pm	17.50	0.58	10.1500	50.0
1:30 pm	17.48	0.58	10.1384	53.0
2:00 pm	16.59	0.58	9.6222	56.5
2:30 pm	16.28	0.58	9.4424	58.2
3:00 pm	16.18	0.58	9.3844	60.3
3:30 pm	15.31	0.54	8.2674	60.2
4:00 pm	15.20	0.51	7.7520	59.7
4:30 pm	15.10	0.50	7.5500	58.2
5:00 pm	15.04	0.47	7.0688	56.8
5:30 pm	11.28	0.43	4.8510	55.5
6:00 pm	9.16	0.34	3.1134	50.1
6:30 pm	7.34	0.20	1.4680	48.7
7:00 pm	6.21	0.18	1.1178	45.5
7:30 pm	5.55	0.15	0.8325	40.8



## X. Conclusion

The hybrid renewable energy generation system combining solar, wind, and tidal energy provides a sustainable and environmentally friendly solution for future electricity demand. The proposed system improves reliability, reduces dependence on fossil fuels, and minimizes environmental impact. By integrating multiple renewable resources, the system can provide continuous power generation suitable for rural, coastal, and remote regions. The adoption of such hybrid technologies can contribute significantly to green energy development and sustainable growth.

## XI. Future Scope

The average per capita consumption of energy in India is around 500 W, which is much lower than that of developed countries like USA, Europe, Australia, Japan etc. However, this figure is expected to rise sharply due to high economic growth and rapid industrialization. The consumption of electricity is growing on the worldwide basis. Energy is a necessity and sustainable renewable energy is a vital link in industrialization and development of India. A transition from conventional energy systems to those based on renewable resources is necessary to meet the ever-increasing demand for energy and to address environmental concern.

## References

1. P. P. Shirsath, A. Pise, and A. Shinde, "Solar-Wind Hybrid Energy Generation," *International Journal of Engineering Research and General Science*, vol. 4, no. 2, pp. 724–731, 2016.
2. M. V. P. Geetha Udyakanthi, "Design of a Wind Solar Hybrid Power Generation System in Sri Lanka," 2015.
3. A. K. Vadakkepurakkal, "Design of a Hybrid Power Generation System Using Solar-Wind Energy," 2018.
4. G. Halasa and J. Asumadu, "Design of Wind Solar Hybrid Electrical Power Production," vol. 1, no. 2, 2009.
5. P. Jenkins, "Hybrid Power Generation Using Solar and Wind Energy," 2019.
6. A. Askarzadeh, "Electrical Power Generation by an Optimised Autonomous PV/Wind/Tidal/Battery System," *IET Renewable Power Generation*, vol. 11, no. 1, pp. 152–164, 2017.
7. P. B. L. Neto, O. R. Saavedra, and D. Q. Oliveira, "The Effect of Complementarity Between Solar, Wind and Tidal Energy in Isolated Hybrid Microgrids," *Renewable Energy*, vol. 147, pp. 339–355, 2020.
8. V. Khare, "Prediction, Investigation, and Assessment of Novel Tidal–Solar Hybrid Renewable Energy System in India by Different Techniques," *International Journal of Sustainable Energy*, vol. 38, no. 5, pp. 447–468, 2019.
9. R. Singh and R. C. Bansal, "Optimization of an Autonomous Hybrid Renewable Energy System Using Reformed Electric System Cascade Analysis," *IEEE Transactions on Industrial Informatics*, vol. 15, no. 1, pp. 399–409, 2019.
10. S. Ben Elghali, R. Outbib, and M. Benbouzid, "Selecting and Optimal Sizing of Hybridized Energy Storage Systems for Tidal Energy Integration Into Power Grid," *Journal of Modern Power Systems and Clean Energy*, vol. 7, no. 1, pp. 113–122, 2019.
11. H. A. Fathabadi, "Novel Stand-Alone Hybrid Solar/Wind/Fuel Cell Power Generation System," *Energy*, vol. 86, pp. 195–204, 2015.
12. S. Rehman and L. M. Al-Hadhrami, "Study of a Solar PV–Wind–Battery Hybrid Power System," *Renewable Energy*, vol. 36, no. 1, pp. 305–313, 2011.



13. H. Yang, W. Zhou, L. Lu, and Z. Fang, "Optimal Sizing Method for Stand-Alone Hybrid Solar-Wind System With LPSP Technology," *Solar Energy*, vol. 82, no. 4, pp. 354–367, 2008.
14. R. Belfkira, L. Zhang, and G. Barakat, "Optimal Sizing Study of Hybrid Wind/PV/Diesel Power Generation Unit," *Solar Energy*, vol. 85, no. 1, pp. 100–110, 2011.
15. A. Chauhan and R. P. Saini, "A Review on Integrated Renewable Energy System Based Power Generation for Standalone Applications," *Renewable and Sustainable Energy Reviews*, vol. 38, pp. 99–120, 2014.
16. M. A. Hossain, H. R. Pota, M. J. Hossain, and F. Blaabjerg, "Evolution of Microgrids With Hybrid Renewable Energy Systems," *Renewable Energy*, vol. 138, pp. 1195–1214, 2019.
17. A. Maleki and F. Pourfayaz, "Optimal Sizing of Autonomous Hybrid Photovoltaic/Wind/Battery System," *Renewable Energy*, vol. 85, pp. 977–987, 2016.
18. A. Beluco, P. K. de Souza, and A. Krenzinger, "A Dimensionless Index Evaluating the Time Complementarity Between Solar and Hydraulic Energies," *Renewable Energy*, vol. 33, no. 10, pp. 2157–2165, 2008.
19. J. Jurasz, F. A. Canales, A. Kies, M. Guezgouz, and A. Beluco, "A Review on the Complementarity of Renewable Energy Sources," *Renewable and Sustainable Energy Reviews*, vol. 120, 2020.
20. P. Roy, J. He, T. Zhao, and Y. V. Singh, "Recent Advances of Wind-Solar Hybrid Renewable Energy Systems for Power Generation: A Review," *IEEE Open Journal of the Industrial Electronics Society*, vol. 3, pp. 81–104, 2022.
21. A. Sinha and S. S. Chandel, "Review of Software Tools for Hybrid Renewable Energy Systems," *Renewable and Sustainable Energy Reviews*, vol. 32, pp. 192–205, 2014.
22. H. Ibrahim, A. Ilinca, and J. Perron, "Energy Storage Systems—Characteristics and Comparisons," *Renewable and Sustainable Energy Reviews*, vol. 12, no. 5, pp. 1221–1250, 2008.
23. M. Aneke and M. Wang, "Energy Storage Technologies and Real Life Applications," *Applied Energy*, vol. 179, pp. 350–377, 2016.
24. D. Kumar and F. Zare, "A Comprehensive Review of Wind-Solar Hybrid Energy Systems," *Renewable and Sustainable Energy Reviews*, vol. 56, pp. 323–344, 2016.
25. Y. Pavankumar, R. Kollu, and S. Debnath, "Multi-Objective Optimization of Photovoltaic/Wind/Biomass/Battery-Based Grid-Integrated Hybrid Renewable Energy System," *IET Renewable Power Generation*, vol. 15, no. 10, pp. 2200–2215, 2021.
26. K. Balasubramanian, N. Murugesan, A. M. R. Samuel, and M. Sampath, "Lyapunov-Based Energy Optimization for Hybrid Renewable Energy System for Coastal Area," *Proceedings of the Institution of Mechanical Engineers, Part A: Journal of Power and Energy*, vol. 239, no. 6, pp. 995–1007, 2025.
27. K. A. Nair and N. Garlapati, "A Comprehensive Review of Hybrid Wind-Solar Energy Systems," *IOP Conference Series: Earth and Environmental Science*, vol. 1372, 2024.
28. A. Ahmed and M. N. Haji, "Advancing Offshore Renewable Energy: Techno-Economic and Dynamic Performance of Hybrid Wind-Wave Systems," 2025.
29. J. E. C. Saire, J. A. G. Roque, and F. Canziani, "Study of a Hybrid Photovoltaic-Wind Smart Microgrid Using Data Science Approach," 2021.
30. W. Liao, B. Bak-Jensen, J. R. Pillai, Z. Yang, and K. Liu, "Short-Term Power Prediction for Renewable Energy Using Hybrid Graph Convolutional Network and Long Short-Term Memory Approach," 2021