



IMPLEMENTATION OF LINE FOLLOWER ROBOT USING EMBEDDED SYSTEM

Dr.J.S.Prasath, Professor, Dept. of Computer Science, Sapthagiri NPS University.
Hardik V Adagooru, B.E Student, Dept. of Computer Science, Sapthagiri NPS University.
Guduba Prashant, B.E Student, Dept. of Computer Science, Sapthagiri NPS University.
Gunashree B, B.E Student, Dept. of Computer Science, Sapthagiri NPS University.
Gowthami M, B.E Student, Dept. of Computer Science, Sapthagiri NPS University.

ABSTRACT

The line follower robot is an automated vehicle that tracks a visual line embedded on the surface. Line follower robots are used to support the automated production operations. They are also utilized in military applications, human assistance purposes, and delivery services. This proposed work is the implementation of embedded based Line Follower Robot which creates a smart autonomous system capable of navigating a path while sharing real-time data. Infra-red (IR) sensors is utilized to detect and follow a line, typically black on a white surface, and it is controlled by the Arduino microcontroller. IR sensors radiate infrared light and measure the intensity of reflected light to identify the presence and position of the line. This proposed line follower robot is used in wide range of applications including industrial automation, educational projects, warehouse logistics, and small autonomous vehicle systems. These robots rely on sensors to perceive the line and motors to navigate the path according to programmed algorithms.

Keywords: Robot, Sensor, Embedded System, DC motor, Motor Driver.

I. Introduction

Robotics is a branch of engineering that deals with the study of design, manufacturing, operation, and applications of machines that can emulate human intelligence and actions. These machines are called Robots. Robots are designed and programmed to perform human activities. Robotics has a long history, as the first robot was developed in the mid-20th century. Robotics is being used across almost every industry, ranging from IT to healthcare and manufacturing. The concept of the line follower robot is related to light. Here, we use the behaviour of light on the black-and-white surface. The white colour reflects all the light that falls on it, whereas the black colour absorbs the light. The principle of the line follower robot is it provides a line drawn on the floor and guides the sensor, that is, the robot. Line-follower robot utilizes IR transmitters and receivers to send and receive the lights. When IR rays fall on a white surface, they are reflected toward the IR receiver, generating some voltage changes. An infrared sensor emits light to detect certain surroundings. In the infrared spectrum, all the objects radiate some form of thermal radiation that is invisible to our eyes, but an IR sensor can detect these radiations. The IR LED is an emitter, and the IR photodiode is a detector. An IR LED emits the IR light, and the photodiode is sensitive to this IR light. When IR light falls on the photodiode, the output voltages and the resistances will change in proportion to the magnitude of the received IR light. Black surfaces absorb infrared radiation and do not reflect any of the rays that fall on them and no photons reach the infrared receiver. L298N is one of the easiest and best ways to control DC motors. It is the two-channel motor driver that can control the speed and spinning direction of DC motors. This L298N motor driver is a high-power motor driver module. It is used for driving DC and stepper motors. This motor driver consists of an L298N motor driver IC, a 5V voltage regulator, resistors, capacitor, power LED, and 5V jumper in an integrated circuit.



II. Types of Line Follower Robots

There are a few versions of the line follower robots that provide varied functionalities and capabilities. These includes basic line follower robot, advanced line follower robot, and fast line follower robot.

2.1 Basic Line Follower Robot

A simple line follower robot is a type of robot that follows a simple line, generally straight or curved track. It involves designing the mechanical portion or the body of the robot, defining the kinematics of the robots, and designing the control of the robot. A basic Line follower robot can consist of a base at the two ends of which the wheels are mounted. A rectangular sheet of hard plastic can be used as the base. Further a rigid body like a cylinder can be added along with other shaped bodies inter connected with each other by joints, and each with its defined motion in particular direction. The Line follower robot can be a wheeled mobile robot with a fixed base, a legged mobile robot with multiple rigid bodies interconnected by joints.

2.2 Advanced Line Follower Robot

Advanced models include sensors which trace more difficult paths such as intersections and curvy turns and it can also be enhanced with a speed controller. According to the complexity of the path, the robot will slow down or go faster.

2.3 Fast Line Follower Robot

The design of the fast line follower robot is with the intention to have it operate speedily and effectively. This type of line follower robots utilizes optimal sensor positioning, high-speed motors, and the complicated algorithms in order to decrease the amount of time taken for position correction. They are widely used in robotics competitions, where the main criterion is the speed at which the robot moves.

III. Literature

An autonomous line follower robot is developed which enables detection and following a path, usually denoted by a black line on a distinct white surface [1]. The objective of this robot is to establish the practical application of automation, reducing human effort and improving efficiency in both industrial and educational environment. Internet of Things (IoT) based line follower robot is developed that enables remote monitoring and control through web or mobile application [2]. The robot is built with sensors that detect and follow a line, generally marked on the ground, allowing it to makeover through various routes. A tiny line follower robot is designed for the purpose of competitions [3]. This robot alter the motor direction by providing signal to driver IC according to receives signals from sensors. an autonomous line-following robot is designed, developed, and evaluated using an Arduino Uno microcontroller [4]. The robot traverses a predefined path marked by a line, employing infrared (IR) sensors for detection and a Proportional-Integral-Derivative (PID) control algorithm is used for motor control. The line follower robot is developed that follows a line on its given path based on the signal received from the Infrared (IR) sensors [5]. It detects the line and sends the information to comparator and then to the motor driver which drives the motors. The line follower robot is developed that follows certain paths and can detect objects and edges using ultrasonic frequencies [6]. It has been built in a way that any obstacle in front of it can be identified. It will stop and will not pass until the barrier remains. Automatic pick and place robot is developed using Arduino [7]. It is capable of lifting weights by introducing high torque providing motor large weights can be picked. Line follower robot is developed that handles additional products in a manufacturing process in less time with better accuracy [8]. This smart and intelligent robot has more benefits and it does not consume much power. The review of development of a line follower robot is performed for a surveillance camera monitoring system [9]. The closed loop control fuzzy

logic algorithm is utilized which frequently correct incorrect movements of the mobile robot using a feedback mechanism. The development of a line follower wheeled mobile robot is proposed [10]. The IC8051 microcontroller is utilized to respond towards the data obtained from the IR sensors and provides quick, smooth, accurate and safe movement of the robot.

IV. Proposed Work

This proposed work is the implementation of line follower robot using embedded system. The steps involved in line follower robot are line detection, signal processing, corrective action, and cyclic process. Figure 1 illustrates the operations involved in the line follower robot. An IR sensor is used to detect and follow a line on the ground, usually a black line on a white surface.

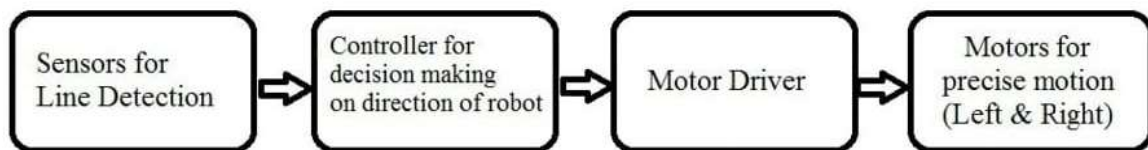

Figure 1: Block diagram of Line Follower Robot

IR sensors scan underneath the robot continuously and notify a difference in reflection between the line and the surrounding surface. The signals acquired from the IR sensors are forwarded to the microcontroller for processing. When the robot reaches the decision that it is on the line, then the microcontroller will keep sending signals to continue moving the robot forward. If the robot goes off line position, then sensors spot the error, and the microcontroller adjusts the speeds of the motor accordingly. When the robot had strayed off position towards the left, then it signalled the microcontroller to increase the right motor while reducing the speed of the left motor with the hope that the robot would correct its direction and come back onto the position. The robot traces the same line over and over again on the ground. This proposed line follower robot is highly accurate and programmed in the microcontroller, provides smoother and faster movement of robot in the line.

V. Developing a Line Follower Robot

The line follower robot is an automated vehicle that follows a visual line embedded on the surface. This visual line is a path on which the line-follower robot moves. The line follower robot is constructed using Microcontroller (Arduino Uno), two IR sensors, motor driver IC (L298N), DC motors, Chassis and Wheels, Power supply (batteries), wires and connectors.

5.1 Chassis Assemble

The initial step of developing the line follower robot is to start with the assembling of the chassis that attaching the wheels and the motors. The chassis should be balanced and lightweight for better motion of the robot.

5.2 Mounting the Sensors

The IR sensors are mounted at the front of the robot where they will sense the line. Usually, two sensors are mounted on each side of the line so that proper sensing can be generated.

5.3 Connecting the Microcontroller

The microcontroller is mounted on the chassis and connects all sensors and motor ICs. All sensors are connected by jumper wires and the motor driver IC with the microcontroller in the right connection.

5.4 Microcontroller Code

Line follower robot is implemented using Arduino code. The basic logic would be to keep robot going straight whenever both the sensors are on the line and make correctional movements when atleast one of them goes off the track.

5.5 Testing the Robot

Once the robot is assembled and uploaded the program in the Arduino microcontroller, then the robot should be tested on the track to check that it moves on the line. The sensitivity should be adjusted with the sensor and speed of the motor.

VI. Hardware and Software Requirements of Line Follower Robot

The essential components required to develop the line follower robot are Arduino microcontroller, Infrared (IR) line sensors, DC motors, motor driver, chassis and wheels. Figure 2 shows the connection diagram of IR Sensors and Motor Driver with Arduino Uno Board.

6.1 Arduino Uno

Arduino microcontroller serves as the robot's brain, processing the input from the IR sensors and controlling the motor rotation based on predefined algorithms.

6.2 Infrared (IR) Line Sensors

IR line sensors detect the line by measuring reflected light intensity from different surface colors. IR sensors are strategically positioned on the robot to detect the line on the ground. The IR emitter emits a constant IR beam. These sensors emit infrared light and measure the intensity of reflected light to determine the presence and position of the line. The white surface reflects most of the beam while the black surface absorbs most of the beam. This reflected beam is picked up by the IR detector and its conduction increases. The output voltage change is 0V for absence of IR rays and it is 5V for maximum intensity. This is given to the comparator to compare with a reference signal generated by the potentiometer.

6.3 DC Motors

The role of DC motor is to drive the wheels and enable movement of robot along the path. DC motors provide the driving force for the robot's movement. The rotation of the motors allows the robot to move along the detected line.

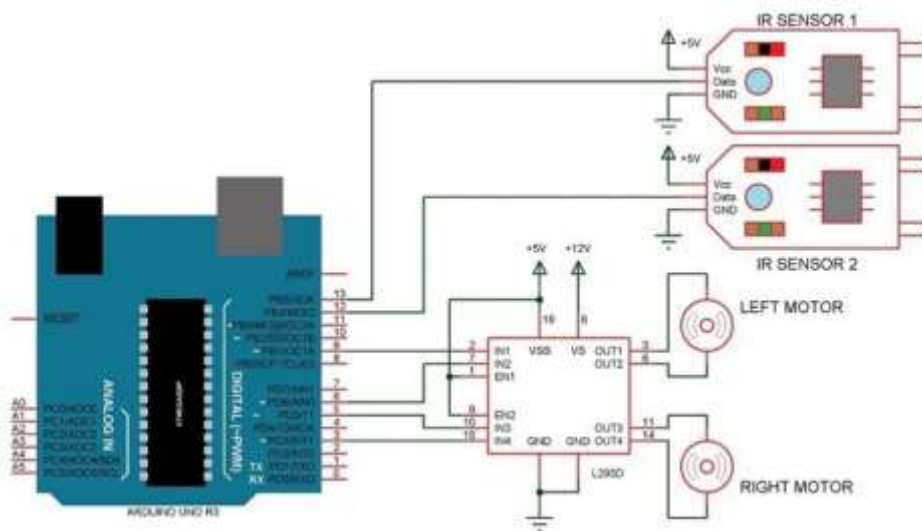

Figure 2: Circuit connection of IR Sensors and Motor Driver with Arduino Uno Board

6.4 L298N Motor Driver

The L298N motor driver acts as an interface to regulate motor direction and speed based on Arduino commands. The motor driver acts as an interface between the Arduino Uno and the DC motors. It provides the necessary power and control signals to regulate motor speed and direction.

6.5 Chassis and Wheels

It provides the structural support and mobility for autonomous traversal. The chassis serves as the structural framework that supports and preserves the internal components of the robot. It is typically made of durable materials such as plastic or aluminium and is designed to withstand the rigours of robotic movement. Wheels are attached to the DC motors and provide traction and stability for the robot as it moves along the line. The size and type of wheels may vary depending on the terrain and intended use of the robot.

6.6 Power Supply

Microcontroller and motors requires battery power supply or voltage regulators. Additional modules like LED indicators or buzzers may be included for feedback. A power supply, such as a battery pack or external power adapter, provides the necessary electrical energy to operate the microcontroller, sensors, motors, and other electronic components.

VII. Results and Discussion

A line following robot is a type of autonomous mobile robot designed to follow a specific path marked by a line, usually black on a white surface or vice versa. The implementation of line follower robot involves integrating sensors, microcontrollers, and motor drivers to enable real-time path tracking and movement control.



Figure 3: Implementation of Line Follower Robot using Embedded System

Figure 3 shows the implementation of line follower robot using embedded system. It includes IR sensors, Arduino Uno board, L298N motor driver, DC motor, chassis and wheels. This proposed line follower robot utilizes infrared (IR) sensors to detect the line and sends signals to the Arduino microcontroller which processes the input and adjusts the motors accordingly. The motors are controlled via a motor driver circuit, allowing the robot to steer left or right based on the line's position.

VIII. Applications of Line Follower Robot

Line follower robots have numerous applications in various industries. It is widely used in industrial automation, warehousing, competitions, education and learning.

8.1 Industrial Automation

Line follower robots are applied in manufacturing companies to carry commodities along specifically prescribed pathways for material handling in the most efficient and accurate manner.



8.2 Warehousing

Warehouse automation mainly employs line follower robots that move the inventory from one location to another. The robots follow the prescribed pathways, which results in reduced labour for humans and increased operational speed.

8.3 Competitions

Competition events for building line followers often involve building the fastest and most accurate line follower robot. These events push design and programming skills to the maximum to develop the fastest line follower robot.

8.4 Education and Learning

As a hands-on tool, line followers introduce students to topics such as sensors, automation, and control systems. Line follower robots are essential educational tools that teach core concepts of robotics, electronics, and programming through hands-on building and programming, develop problem-solving, logical thinking, and engagement with sensors, microcontrollers, and automation.

IX. Challenges in Designing Line Follower Robot

The development of an efficient line follower robot is cumbersome and difficult to design especially when dealing with complex tracks. Some of the common challenges involved in the development of such robots include:

9.1 Calibration of Sensors

The sensitivity of sensors has to be well-calibrated. The wrong calibration causes the robot to lose track, and frequent deviation mostly occurs.

9.2 Optimization of Speed

The balance between speed and accuracy is important for the fastest line follower robot demands an outstanding mixture. For line followers to be the fastest, they may either overshoot some of the turns or fail to make some quick corrections because of high speeds.

9.3 Power Management

The selection of a power supply is another significant factor in its performance as a robot. This is because inadequate power will result in increasing slouchy movements, while too much power is likely to damage materials.

X. Future Trends in Line Follower Robot

The extension of this proposed work is to integrate the line follower robot with Internet of Things (IoT) which enables real-time monitoring of speed, direction, and sensor status in mobile app or on a web dashboard. Data related to the distance travelled by the line follower robot and line deviation can be stored on cloud for further analysis. With the help of IoT, remote control of line follower robot is possible through smartphone or web browser. The notification and alert message can also be sent to the mobile when the robot loses the line or encounters an obstacle. The various platforms such as Blynk, ThingSpeak, or Firebase can be utilized for IoT dashboards.

With continuous improvements in Artificial Intelligence (AI) and sensor technologies, line follower robots will definitely shine in the future. Some trends that might shape the future of these robots include:

10.1 AI-Enabled Line Follower Robots

Line follower robot will be able to learn about their surroundings through the support of artificial intelligence, and based on the data obtained from the sensor, real-time changes can be made. AI enhances the performance of line follower robot in tracking the complex as well as multiple lines and gives better accuracy on varied environments.

10.2 Multi-Tasking Robots

Future line follower robots can be applied for different range of applications, from just following one simple line to being operational in other kinds of applications that might include interaction with other systems or carrying certain objects even cooperating with swarms of other robots.



10.3 Velocity and Efficiency

The innovation in sensor technology, motor design, and programming algorithms will keep on facilitating a faster line follower robot. These are developments that would look to push the speed to the outer limits as these robots continue to be more competitive.

XI. Conclusion

Line-follower robots are mobile robots designed to identify and follow lines marked on surfaces, usually made of distinct colors like black on white. This proposed line follower robot is implemented using infrared (IR) sensors, Arduino microcontroller, DC motor, motor driver, chassis and wheels. IR sensor is used to detect the line and transmits the signals to the Arduino microcontroller which processes the input and adjusts the motors accordingly. The motors are controlled through a motor driver circuit, allowing the robot to steer left or right based on the line's position. This proposed line follower robots are suitable for a school project, a robotics competition, or an industrial application. This work can be utilized for smart factory logistics where robots follow paths to transport goods, warehouse automation in which the real-time tracking of robot movement is performed, educational robotics to perform teaching embedded systems and IoT, and surveillance robots. This proposed work can be extended by integrating the line follower robot with Internet of Things (IoT) which enables real-time monitoring of speed, direction, and sensor status in mobile app or on a web dashboard.

References

- [1] Sarika, K.; Himesh, S.; Aryan, C.; Vishwajeet, P.; Omkar, W. Line Follower Robot. *Int. J. of Advanced Research in Science, Communication and Technol.* 2025, 5, 279–282.
- [2] Subhashini, M.; Balaji, Vignesh, C.; Palani, Sai S.R. Line Follower Robot using Internet of Things. *Int. J. of Research in Eng. IT and Social Sciences.* 2025, 15, 188–200.
- [3] Jyothilal, N.B.; Sreenadh, B.; Vinod, B. Design and Implementation of Line Follower Robot. *Industrial Engineering Journal.* 2024, 53, 1–8.
- [4] Abhishek, S.; Apoorva, N.; Ayushi, N.; Anmol, J.; Uma, S.K. Line Follower Robot using Arduino. *Int. J. of Creative Research Thoughts.* 2024, 12, 7–13.
- [5] Raj, K.; Guna, S.; Keerthi, Suresh, K.; Dinesh, Mouli, Yagneswara, S.; Satti, B.; Pallavi, Naveen. Fabrication of Line Follower Robot. *Int. J. of Research Publication and Reviews.* 2023, 4, 1460–1465.
- [6] Vicky, B.; Arif, I.N.; Shahid, U.R.; Mithun, D.; Shafiul, I.J.; Nazmun, N.; Abhijit, P. An Ultrasonic Line Follower Robot to Detect Obstacles and Edges for Industrial and Rescue Operations. *Int. J. of Computer Applications.* 2020, 176.
- [7] Jagath, H.R. The Line Follower and Pick and Place Robot. *Int. Research J. of Eng. and Technol.* 2020, 7, 1826–1831.
- [8] Bipul, S.; Vinay, R.; Arbaaz, S.; Avinash, P. Design and Fabrication of Line Follower Robot. *Int. J. for Recent Developments in Science and Technol.* 2019, 3, 97–102.
- [9] Saad, Ramli, Marimuthu, Karim, Manap. Development of Line Follower Robot with Camera Surveillance System. *Int. J. of Recent Technol. and Eng.* 2019, 8, 2192–2197.
- [10] Shivam, S.; Prashant, K. Advance Line Following Robot. *Int. J. of Eng. and Advanced Research Technol.* 2017, 3, 23–25.