

Arduino 6DoF Robot using LabVIEW

Dr. AJAYA KUMAR SWAIN,¹ Mrs. SUBHASMITA CHAUDHURY¹* Professor, Dept. Of Electrical Engineering, NIT BBSR,
Asst. Professor DEPT. of Electrical Engineering, NIT BBSR,ajaykumar@thenalanda.com, subhasmita@thenalanda.com

ABSTRACT

This work discusses a development of a 6-axis robotic arm controller (i.e) six degrees or axis of freedom (6DoF) refers to the freedom of movement of a rigid body in three-dimensional space. A servo motor is used to control each of the robot's axes. The Pulse Width Modulated Wave applied to each servo motor at each and every axis can be used to determine the position of each axis. The power block and control block are the two main components of the controller. The control block is carried out using LabVIEW, and the power block is carried out by the Arduino controller. Similar commands are delivered serially through the Arduino board to control the servo motor's position.

Keywords: LabVIEW, Arduino, Servo Motor, Pulse Width Modulation, 6-axis Robotic Arm Controller.

1. INTRODUCTION

A robotic arm is a type of mechanical arm, usually programmable, with similar functions to a human arm; the arm may be the sumtotal of the mechanism or may be part of a more complex robot. The links of such a manipulator are connected by joints allowing either rotational motion (such as in an articulated robot) or translational (linear) displacement. Serial and parallel manipulator systems are generally designed to position an end-effector with six degrees of freedom, consisting of three in translation and three in orientation. This provides a direct relationship between actuator positions and the configuration of the manipulator. Robot arms are described by their degrees of freedom. This number typically refers to the number of single-axis rotational joints in the arm, where a higher number indicates an increased flexibility in positioning a tool. This is a practical metric, in contrast to the abstract definition of degrees of freedom which measures the aggregate positioning capability of a system.

The end effectors, or robotic hand, can be designed to perform any desired task such as welding, gripping, spinning etc., depending on the application. For example, robot arms in automotive assembly lines perform a variety of tasks such as welding and parts rotation and placement during assembly. In some circumstances, close emulation of the human hand is desired, as in robots designed to conduct bomb disarmament and disposal.

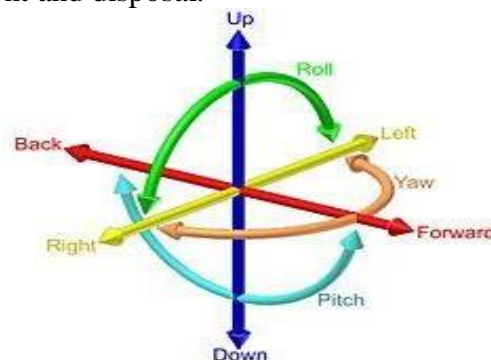

Fig -1: The six degrees of freedom: forward/back, Up/down, left/right, yaw, pitch, and roll

The figure 1 given above shows the motion movement in each axis an example of six degrees of freedom movement is the motion of a ship at sea. It is described as.

Translational envelopes:

- Moving forward and backward on the X-axis. (Surge)
- Moving left and right on the Y-axis. (Sway)
- Moving up and down on the Z-axis. (Heave)

Rotational envelopes:

- Tilting side to side on the X-axis. (Roll)
- Tilting forward and backward on the Y-axis. (Pitch)
- Turning left and right on the Z-axis. (Yaw)

Arduino

Arduino is an open-source electronics platform based on easy-to-use hardware and software. Arduino boards are able to read inputs

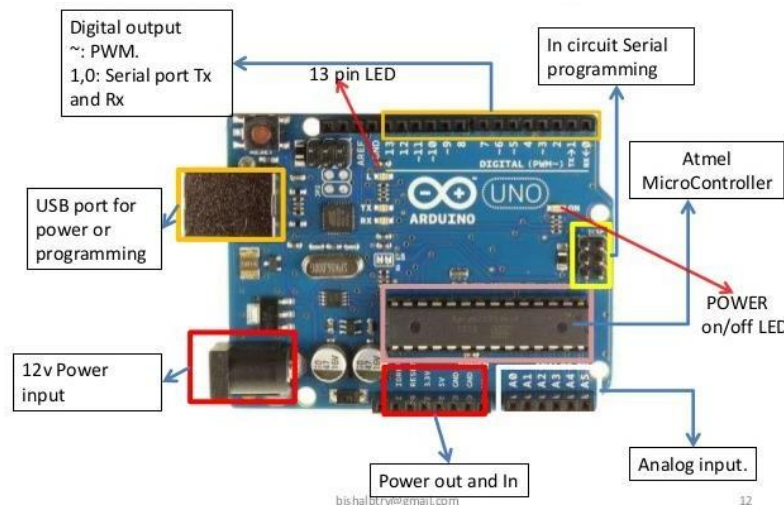

- light on a sensor, a finger on a button, or a Twitter message - and turn it into an output - activating a motor, turning on an LED, by sending set of instructions to the microcontroller on the board

Fig -2 Arduino UNO Description

Arduino can interact with buttons, LEDs, motors, speakers, GPS units, cameras, the internet, and even your smart-phone. Arduino Uno is a microcontroller board based on the ATmega328P (datasheet). It has 14 digital input/output pins (of which 6 can be used as PWM outputs), 6 analog inputs, a 16 MHz quartz crystal, a USB connection, a power jack, an ICSP header and a reset button.

It contains everything needed to support the microcontroller; simply connect it to a computer with a USB cable or power it with an AC-to-DC adapter or battery to get started. Figure 2 shows the

parts of Arduino uno controller.

Arduino Sensor Shield v5.0

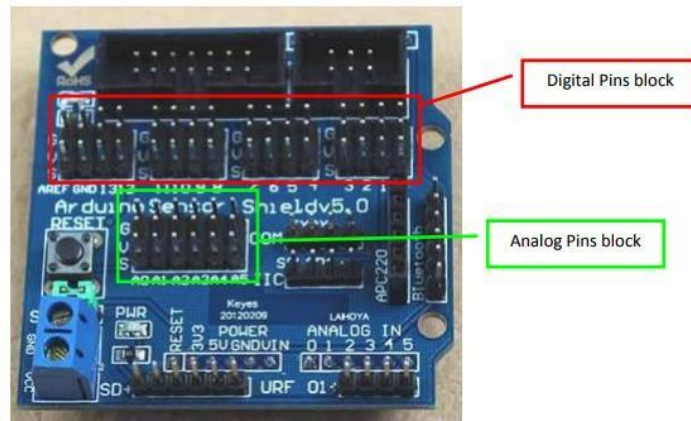

Fig -3 Arduino UNO Sensor shield v5

Figure 3 shows the Arduino Uno sensor shield, which is very useful as a connection point for the many interfaces that can be plugged into the Arduino. Using a sensor shield gives you one +5V (Vcc) and one 0V (Gnd) for every Arduino signal pin. Series of servo motor can be connected easily using such shields and the common power pins are connected to provide the supply power to the servo motors. Servos come with a 3 way socket that plugs straight onto the Sensor Shield G goes to the Brown or Black wire, V goes to the (middle) Red wire, S goes to the Orange wire The good news is as the +5V is in the middle, things will not blow up if it is wired the wrong way round, the servo just will not work until it is plugged in correctly.

LabVIEW

LabVIEW, short for Laboratory Virtual Instrument Engineering Workbench, is a programming environment in which you create programs using a graphical notation (connecting functional nodes via wires through which data flows); in this regard, it differs from traditional programming languages like C, C++, or Java, in which you program with text. However, LabVIEW is much more than a programming language. It is an interactive program development and execution system designed for people, like scientists and engineers, who need to program as part of their jobs. The LabVIEW development environment works on computers running Windows, Mac OS X, or Linux. LabVIEW can create programs that run on those platforms, as well as Microsoft Pocket PC, Microsoft Windows CE, Palm OS, and a variety of embedded platforms, including Field Programmable Gate Arrays (FPGAs), Digital Signal Processors (DSPs), and microprocessors.

2. IMPLEMENTATION OF 6DOF USING LABVIEW USING ARDUINO

Arduino is used as a Data acquisition device to measure, control, monitor different devices and sensors , it is easy to learn Graphical programming than normal programming, this Graphical programming takes less time than usual arduino programming a firmware is been downloaded on to the arduino before interfacing. LabVIEW acts as a graphical user interface (GUI) which provides the control to the servo using Arduino board this can be achieved using a tool called LabVIEW interface for arduino (LIFA) which makes the data transfer easy between arduino and LabVIEW to control the servo motor. The six servo motor are been connect to the six PWM outputs of the arduino uno whose duty cycle such as angular position are been controlled by the LabVIEW and sequence of operations are been performed using LabVIEW. Figure 4 shows the

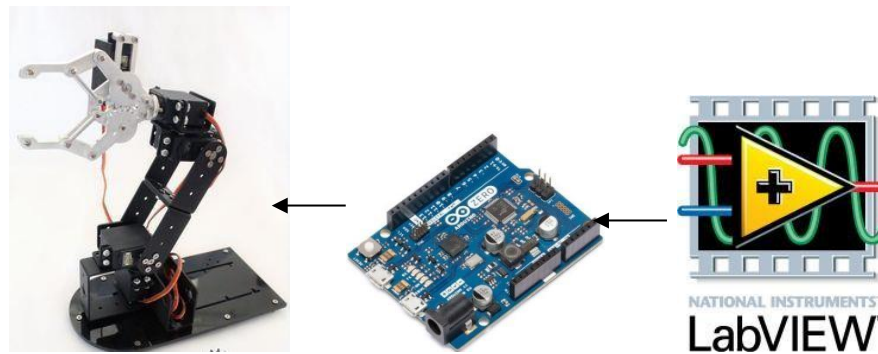
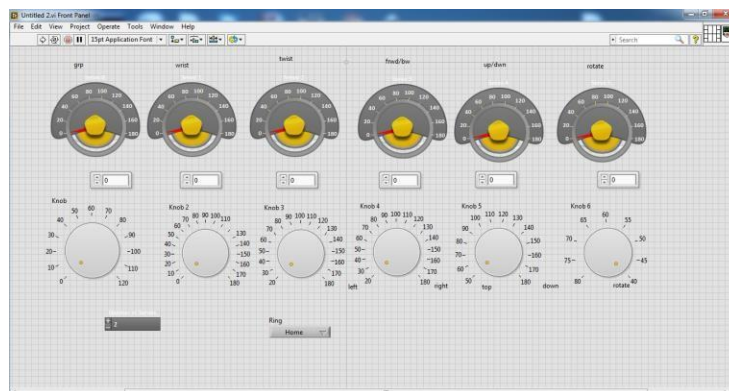

Fig -4: Implementation of 6DoF using LabVIEW using Arduino.

LabVIEW Software Implementation

LabVIEW acts as a GUI which is used to monitor and control the 6DoF robot the LabVIEW is basically of two windows namely front panel which is the user interface and the block diagram window which is the programming part for the desired application. Arduino is been interfaced with LabVIEW using the LIFA tool which is to be installed and once installed the desired function blocks will be available for programming.

The figure 5 given below shows the Front panel implementation in which separate control for each servo motor is been provided using knobs for all the six axes such as Grip, twist, wrist, Forward/Reverse, Top/Bottom, Rotation and independent indicators are been provided for the exact angular location of each servo motors separate control has been giving to extend the number of servos, here upto 15 servos can be connected using this tool. The programming has been done in such a way the pick and place operation is been done by selecting the ring menu in which the process can be selected and the speed of the motor can be controlled by varying the delay between



each sequence.

Fig -5: Implementation of Front Panel

The figure 6 given below shows the block diagram implementation in which the desired logics to be performed is implemented. Initially, the communication is been initialized and the desired com is been selected in which the arduino is connected. The Number of Servos to be used is been selected using a block which is been indicated in the front panel for manual selection with labels for each servo are given to indicate which servo is been provided with the control signal case

structure are been provided perform sequential and manual control of the servo motor and emergency stop sequence are been provided to shut the process of during emergency situation.

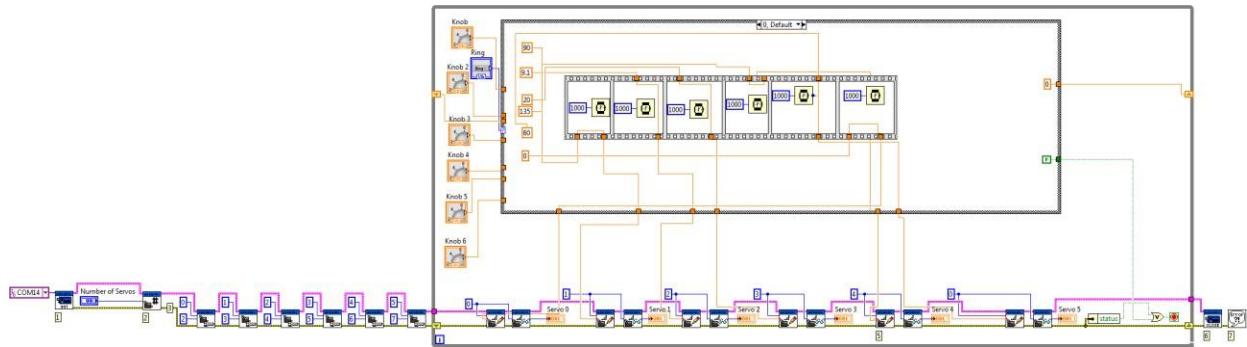
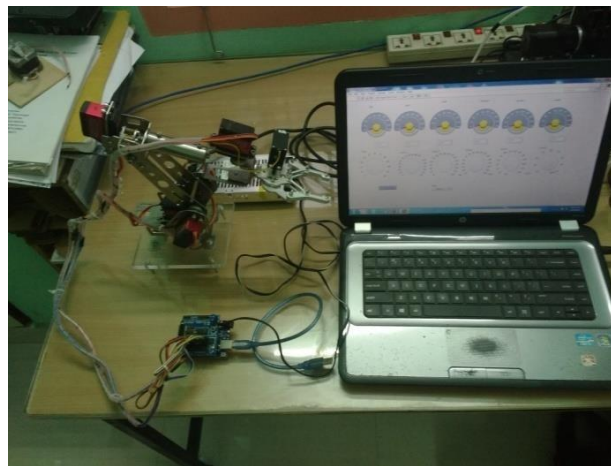

Fig -6 Implementation of Block Diagram

Hardware Implementation

The figure 7 given below shows the hardware implementation of a six axis robot using arduino uno. Here the servo based six axes is used with each servo is of 20kg torque which are been placed in steel assembly for rigidity and end actuator are been provides as a gripper for picking and placing application the servo motor is controlled by Arduino using the sensor shield V5.0 which is been stacked onto the arduino which provides the control signal and power source for the servo motor external 5 v power source of high current such as 40 AH is provided to supply high current to the servo motors.



3. RESULT

Fig -7 Hardware Implementation

The figure 8 give below show the output result of the GUI (Graphical User Interface) in which the pick operation is been select and a perfected constant value for each servo are loaded into the arduino for each servo motor and the operation of pick is executed and the number of servos to be controlled are mentioned the desired angle of each servo are indicated in gauge and digital indicators and the sequence of pick operation in been done serially one by one the operation can be change from pick to place to manually control by selecting the Ring menu.



Fig -8 Output Result

4. CONCLUSION

Due to the growing demand for natural Human Machine Interfaces and robot intuitive programming platforms, a robotic system that allows users to control an industrial robot. Thus in this paper, the implementation of 6DoF (6 degrees of Freedom) based robot using arduino under the LabVIEW platform has been carried out, which makes the hardware and software more easy and effective. Apart from pick and place, 3D printing can also be done in future scope by the same technique.

5. REFERENCE

- [1] J. H. JU, "A Study on error Analysis and Hybrid Motion Control of LabVIEW® -based 3-axis SCARA Robot", School of Mechatronics, Changwon National University, 2008.
- [2] Ashraf Elfasakhany, Eduardo Yanez, Karen Baylon, Ricardo Salgado, Design and Development of a Competitive Low-Cost Robot Arm with Four Degrees of Freedom, Modern Mechanical Engineering, 1, November 2011, 47-55
- [3] S. Calinon, and A. Billard, "Active teaching in robot programming by demonstration," in 16th IEEE International Symposium on Robot and Human interactive Communication, RO-MAN 2007, pp. 702-707, Jeju Island, Korea, 2008.
- [4] J. N. Pires, "Robot-by-voice: Experiments on commanding an industrial robot using the human voice," in Industrial Robot, An International Journal, vol. 32, no.6, pp. 505-511, Emerald, 2005.
- [5] I. Mihara, Y. Yamauchi, and M. Doi, "A real-time vision-based interface using motion processor and applications to robotics," in Systems and Computers in Japan, vol. 34, pp. 10-19, 2003.
- [6] SHIN, K. G. – MCKAY, N. D. (1985): Minimum-Time Control of Robotics Manipulators with Geometric Path Constraints, IEEE of Automatic Control. AC-30, 6, pp.531–541.
- [7] SHIN, K. G.: Trajectory Planning for Robot Control: A Control System Perspective, Control and Dynamic System Series, Advances in Robotics System, 1991, pp. 105–146 (Academic Press Inc.).
- [8] National Instruments Corporation. "Motion control Fundamentals course Manual", 2002-2004.
- [9] Robotics & Automation Magazine, vol. 12, no. 3, pp. 16-23, 2005.