



ASSESSMENT OF USING RENEWABLE ENERGY SOURCES TO ADDRESS THE ELECTRIFICATION OF RURAL AREAS

Dr. C.Nithyanandam, Dept of Electrical and Electronics Engineering, Sree Venkateswara College Of Engineering, Nellore (Dt), Andhra Pradesh, India.

Narmadha, Dept of Electrical and Electronics Engineering, Sree Venkateswara College Of Engineering, Nellore (Dt), Andhra Pradesh, India.

K Girish Kumar, Dept of Electrical and Electronics Engineering, Sree Venkateswara College Of Engineering, Nellore (Dt), Andhra Pradesh, India.

T. Sreekanth, Dept of Electrical and Electronics Engineering, Sree Venkateswara College Of Engineering, Nellore (Dt), Andhra Pradesh, India.

ABSTRACT

How to increase the reliability of the electrical system during peak times is the topic of today's conversation. The grid's stability can be maintained directly by cutting off some loads. One of these loads, particularly in the summer, is street lighting. Since there is no need for grid power, this paper suggests an energy-free street lighting system. The idea is to install a freestanding solar LED street light system. The system that is being proposed consists of a PV panel, a storage system, an LED bulb, a power conditioning system (PCS), and a controller that can control power flow and system functioning. There are various benefits to using LED lighting applications as opposed to other lamps. It is both cost-effective (the life is very lengthy compared to other lights) and has very high efficiency lighting sources. A low dc voltage source is also required for operation. Through the use of available sunlight, the storage system will be charged during the day. The controller, on the other hand, will signal the system to connect the LED lamp so that it is ready for use when it is dark outside. Since the LED only requires a small amount of dc voltage to function, this system only requires a basic dc-dc converter, which lowers the cost of the system as a whole. Also suggested is a low-cost microcontroller to run the entire system. By implementing this concept in Egyptian streets, HID bulbs can reduce the amount of energy used by more than 50%, allowing for the use of tiny PV systems. With the help of this suggested system, streets might be lit up with lower power bulbs while still being cost- and CO₂ emission-free, grid-free, and environmentally beneficial. Furthermore, the suggested solution can address the load demand peak point crisis in Egypt.

Keywords— PV module, light dependent resistor (LDR), lithium batteries, LED array, charge controller.

I. INTRODUCTION

Due to the increase in global energy use on a per-person basis, there is currently a global energy deficit. This caused the global storage of oil and natural gas to continuously decline. Stresses on the ground life have been linked to environmental issues as well. As a result, there is a huge interest in renewable energy technologies to discover solutions to the global energy dilemma. In recent years, PV systems have been used in a variety of applications, ranging from large-scale PV plants that have cumulative power reaches of only a few tenths of GWP to small-scale PV systems that have a power output of only a few tenths of Watts, which are connected to the grid.

The standalone street lighting system using the most effective and economical Light Emitting Diode (LED) bulbs is one of these PV applications. In addition to being an environmentally responsible choice (requiring no power input and being pollution-free), this system, which comprises of a PV panel, a high-quality battery, and an LED bulb, can be installed anywhere independent of the local grid's accessibility. Solar energy is used as the power source since it is environmentally "clean" from

the perspective of energy generation. PV arrays generate electricity using solar radiation. There is no need for fuel to power these units.

There is no need for fuel to power these units. High intensity discharge lamps, on the other hand, are used in the majority of modern street lighting. To decrease the amount of energy used by this type of lamp and the quantity of CO₂ emissions, a lot of emphasis has recently been paid to the hunt for innovative street lighting modules. Given their current capabilities, LEDs have proven to be the best choice for LED street lighting. Numerous benefits of the LED lamp include its extraordinarily long lifespan of 100,000 hours.

Due to the significance of the problem, numerous businesses are now creating, constructing, and manufacturing these street light products. Additionally, a wide range of products with various power ranges and lamp types are available. Examples of the GEO-TECHIK solar street LED light system are shown in Figures 1 and 2.

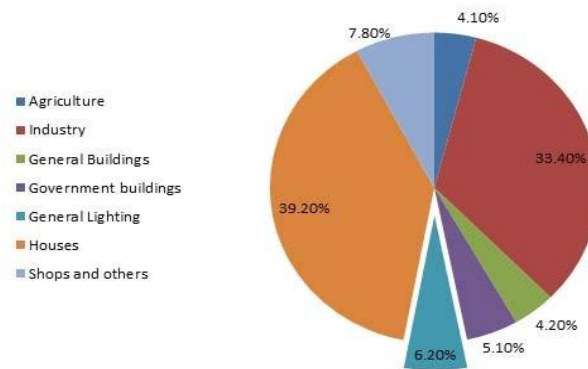

Fig.no.1: Energy consumed in India in 2020-2021

II. THE PROPOSED SYSTEM OPERATIONAL MODES

One microcontroller has been used to implement the intended control loop, which will regulate both the charge and discharge phases. It is important to note that the control should draw the Maximum Power Point (MPPT) from the PV system during the charging time. The MPPT control algorithm built into the microcontroller does this. Since the LED's current determines how bright it is, the microcontroller also uses an LED current control algorithm. The suggested power stage for the system driving the freestanding LED street light is seen in Figure 8. The suggested setup uses 76 Watt street LED lamps. The PV panel, which has an 85 Watt rating at 17 V and a 5 A short circuit current rating, the storage battery system, PCS, and an LED bulb are all included. The system's daytime and nighttime operation modes are depicted in Figures 9 and 10, respectively. The lamp is unplugged during the day, and the system that results is depicted in Fig. 9 where the PV panel is linked to the battery to charge it. Switch Q1 is in the ON state, while switches Q4 and Q5 are in the OFF state. Pulse Width Modulation (PWM) signal is used to synchronously switch the two switches Q2 and Q3. A straightforward boost converter system is formed by switch Q2 with the coil and switch Q3. This is because the battery voltage should be lower than the PV panel voltage. Fig. 11 displays the switching signals for this mode. In the evening, the process is reversed. Since there is no sunlight and no need for operation, switch Q1 should be in the OFF position. However, switch Q3 is activated while switches Q4 and Q5 are run synchronously with PWM. A straightforward boost converter system is composed of switches Q2 and Q3, the coil, and the capacitor Co. This is due to the fact that the LED lamp's load voltage is higher than the battery voltage.

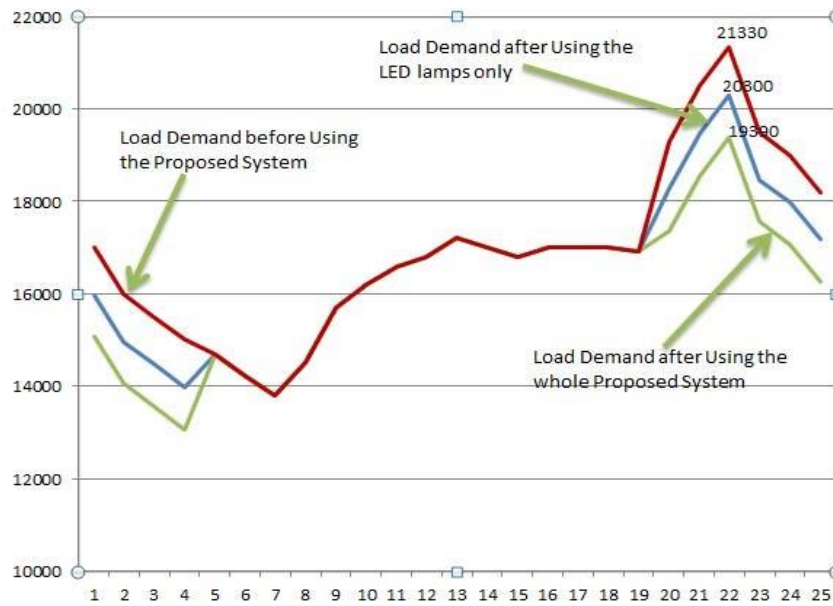

Fig.no.2: Load demand before and after using the proposed system

Through renewable solar energy, this project seeks to electrify rural areas. In terms of electrical energy usage worldwide, India has taken fifth place. Population growth is accompanied by an increase in energy use, which leads to the depletion of nonrenewable energy fuels. Global warming results in temperature increases, deteriorated air quality, radiation exposure, etc.

India primarily uses non-renewable energy sources to produce its electricity. Even though renewable energy sources like hydro, wind, tidal, and biogas are present in the world, they cannot be used effectively because they are only partially available. India is similarly endowed with a vast array of natural resources. There are typically 300 bright days each year, demonstrating India's enormous potential for solar energy. Energy poverty might be reduced in a significant way by solar energy. India receives 5 to 7 kWh/m² of solar radiation for 300 days out of the year. The potential for power generation utilising solar photovoltaic technology is thought to be around 20 MW/sq km, and the potential for solar thermal generation is thought to be about 35 MW/sq km. In an effort to satisfy the needs of a rising country, the Indian energy sector has recently experienced unprecedented growth.

In addition to being a non-polluting and environmentally friendly solution, this system may be installed anywhere regardless of the state of the local grid. Solar energy is used as the power source since it is environmentally "clean" from the perspective of energy generation. PV arrays generate electricity using solar radiation. There is no need for fuel to power these units.

High intensity discharge lamps, on the other hand, are used in the majority of modern street lighting. To decrease the amount of energy used by this type of lamp and the quantity of CO₂ emissions, a lot of emphasis has recently been paid to the hunt for innovative street lighting modules. With their current performance, LEDs have established themselves as the best option for LED street lighting. The LED lamp has a lot of benefits, such as its extraordinarily long lifespan of 100,000 hours, extraordinary resilience due to the absence of glass components or filaments, lack of an external reflector, modular construction, lack of emissions similar to those produced by HID lights, and most importantly, its high efficiency.

III. BLOCK DIADRAM

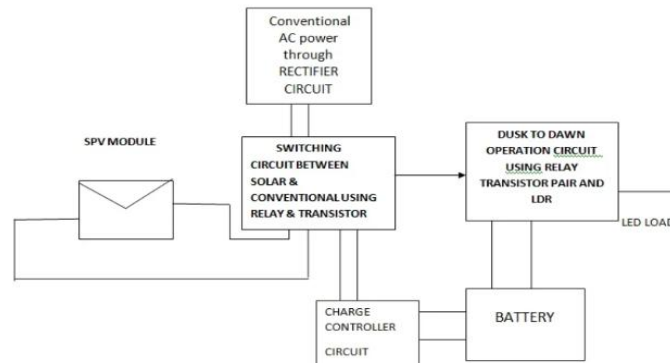

Fig.no.3

IV. MODEL OF SOLAR STREET LIGHT

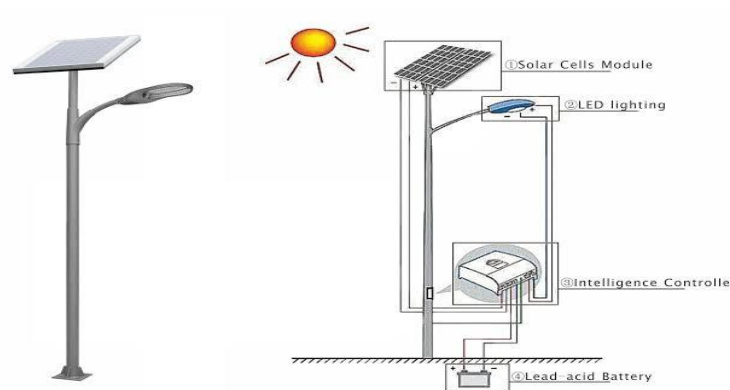

Fig.no.4

1. Solar modules use light energy (photons) from the sun to generate electricity through the photovoltaic effect.
2. In this project we are using a solar panel of 80watt which can give voltage up to 21.5v and having maximum current of 4.4 amp.

TYPES OF SOLAR PANELS:

There are three types of solar panels

They are;

1. Mono crystalline solar panels.
2. Poly crystalline solar panels
3. Thin film (amorphous) solar panels

Mono crystalline solar panels:

A solar panel made up of mono crystalline solar cells is referred to as a mono crystalline solar panel. Similar to a semiconductor, these cells are constructed from a cylindrical silicon ingot that was produced from a single, highly pure silicon crystal. Wafers are cut from the cylindrical ingot to create cells.

POLY CRYSTALLINE SOLAR PANELS:

Poly crystalline silicon is also called poly silicon.

It is quite pure.

The electronics and solar photovoltaic industries both use it as a raw material.

It is created using the Siemens process, a chemical purification method from silicon of metallurgical grade.

It also goes by the name multicrystalline.

THIN –FILM SOLAR PANEL:

The purpose of a thin-film solar panel is to transform light energy into electrical energy.

It is made up of thin, deposited layers of photon-absorbing material on a flexible substrate.

DETERMINATION OF RATING OF SOLAR PANEL:

1. A 16-watt LED setup is being used here.
2. There are 12 hours of operating time every day.
3. The panel's rating is then created in accordance with that.
4. The load here requires 192 watt-hours of energy.

Battery:

1. We function as a storage facility. Through a charge controller circuit, the battery is charged from both solar and conventional sources.
2. Using a 24 volt, 80 amp battery
3. Lead acid batteries have historically been the norm for solar energy storage.
4. After all, they have been in use for more than a century and are a tried-and-true technology.

TYPES OF BATTERIES:

1. Lead acid type battery
2. Lithium ion type battery
3. Nickel cadmium type battery
4. Flow type battery

Determination of rating of battery:

The selection of battery depends on two factors:

1. Depth of discharge of battery(DOD).
2. System voltage

In solar PV, the deep discharge batteries are used with DOD in the range of 60% and considering 12v systems for this calculation.

Light dependent resistor (LDR):

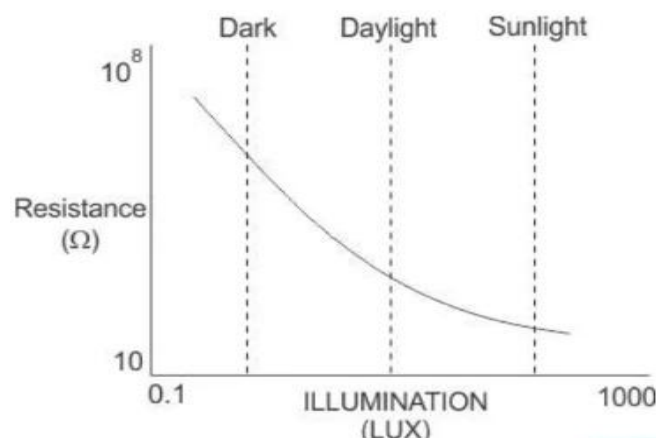

Fig.no.5

1. Photo resistors are light-sensitive resistors, and as the amount of light they are exposed to rises, their resistance lowers.

2. An LDR sensor is nothing more than a light-dependent resistor, and when light intensity changes, so does its resistance.
3. A photosensitive substance makes up the LDR sensor.
4. It modifies a circuit's functionality depending on light levels.

Light emitting diode (LED):

1. LEDs last longer than CFL lights.
2. They use less power.
3. They may be recycled, unlike conventional bulbs.
4. Less heat generation and maintenance.

Working principle:

1. The street light contains a charge controller circuit that charges the battery both when solar energy is present by means of a solar panel and when it is not, by using conventional electricity.
2. The relaying activity is what causes this shift between conventional and solar.
3. Two transistors with NOT logic that are controlled by LDR perform the relaying.
4. The LDR, or light-dependent resistor, is a photoconductive device that turns on or off LEDs both during the day and at night and also performs dusk-to-dawn operation. Its resistance increases proportionally to the amount of illumination.
5. Photovoltaic or solar cells, which are used in solar street lights, are the basis of their operation.
6. Solar energy that is captured by the battery and converted by the solar cell.
7. The solar lamp draws the current from this battery and it requires on other wiring

Circuits:

Here four circuits are used with proper functioning.

1. CHARGE CONTROLLER CIRCUIT
2. DUSK TO DAWN OPERATION CIRCUIT
3. SWITCHING CIRCUIT BETWEEN CONVENTIONAL AND SOLAR
4. POWER CIRCUIT

DUSK TO DAWN CIRCUIT:

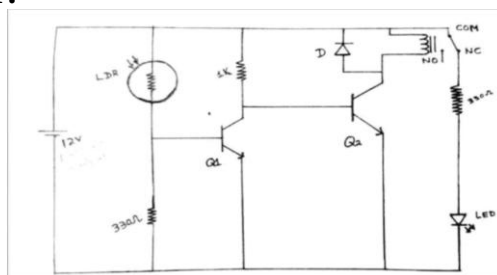

Fig.no.6

WORKING OF DUSK AND DAWN CIRCUIT:

A light-dependent resistor, an n-channel MOSFET, a 12 volt led light, a small inverter, and a few additional parts make up its structure.

The 12 volt battery-operated circuit is built so that both the load, which powers the LED tiny inverter circuit, and the circuit itself are powered by the same battery source.

The circuit uses resistors R1 and R2 as a voltage divider and a current limiter, respectively. As a circuit deactivation indicator, LED is employed.

CHARGE CONTROLLER CIRCUIT:

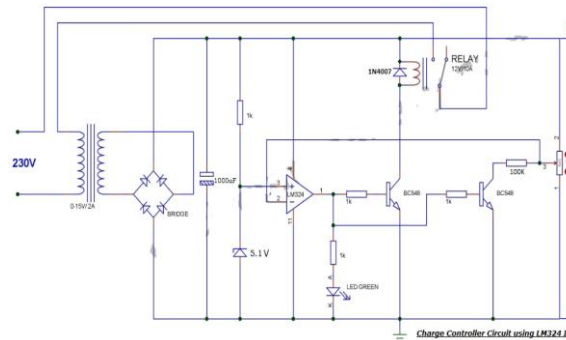

Fig .no.7

WORKING OF CHARGE CONTROLLER CIRCUIT:

To prevent electrical overload, overcharging, and possibly over voltages, a charge controller, charge regulator, or battery regulator restricts the rate at which electric current is added to and extracted from electric batteries.

SWITCHING CIRCUIT:

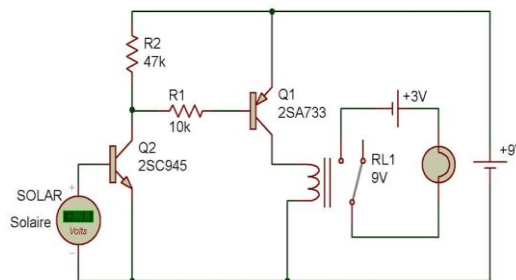

Fig.no.8

WORKING OF SWITCHING CIRCUIT:

Two network nodes create a dedicated communication circuit through the network using the switching circuit method of telecommunications before they may communicate. The circuit ensures that the channel will have its full bandwidth and stays connected throughout the communication session. The circuit operates as though the nodes were physically linked, just like in an electrical circuit. Analogue telephone networks are where circuit switching first appeared. Without using a dedicated circuit, the switching centre transports data in the form of data packets between the numerous distinct nodes.

POWER CIRCUIT:

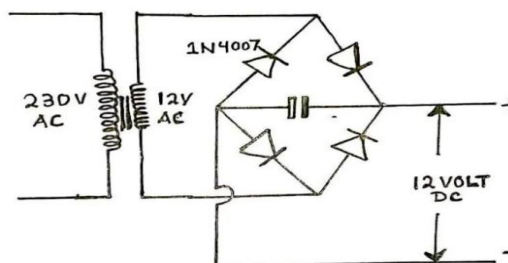

Fig.no.9

WORKING OF POWER CIRCUIT:

A source of electric current, two current-carrying wires, and a light bulb make up an electric circuit. Both cables have one end linked to the terminal of a cell and the other to the free end of a light bulb. By turning off the light, the electrical circuit is disrupted.



The pace at which electrical energy is transported across an electric circuit, measured in units of time, is known as electric power.

TYPES OF ELECTRIC POWER CIRCUIT:

There are 5 types

They are:

1. Close circuit
2. Open circuit
3. Short circuit
4. Series circuit and Parallel circuit

CONCLUSION

However, in the current situation, there are no continuous current sources and no sources of light like street lights in remote areas, rural villages, or small villages. It directly addresses the two issues that the world is currently dealing with, saving of This project, "SOLAR STREET LIGHTING IN REMOTE AREAS," is the most efficient, useful, environmentally friendly, and secure approach to conserve electricity. Inefficient use of incandescent lamp energy and disposal. Now, we can conserve energy by using maintenance-free lights instead of transmission lines, which incur losses. In conclusion, it is a cheap technology that makes security easy to offer.

REFERENCES

1. Solar electrification by using renewable energy sources reference Manual by G mckillop¹, H W Pepper², R Butt² and D W Poole¹. Central Science Laboratory, Sand Hutton, York, YO41 1LZ. Forestry Commission, Alice Holt Lodge Wrecclesham, Farnham, Surrey, GU10 4LH.
2. Solar electrification by using renewable energy sources manual-Wildlife management series.
3. Solar electrification by using renewable energy sources for Bears-Department of games and inland fisheries Virginia.
4. Solar Energy for street light , 2015 IEEE Conference on Technologies for Sustainability (SUS Tech).
5. R. E. Sorace, V. S. Reinhardt, and S. A. Vaughn, "High-speed digital-to-RF converter," U.S. Patent 5 668 842, Sept. 16, 1997.
6. (2002) The IEEE website. [Online]. Available: <http://www.ieee.org/>
7. A. Karnik "Performance of TCP congestion control with rate feedback: TCP/ABR and rate adaptive TCP/IP," M. Eng. thesis, Indian Institute of Science, Bangalore, India, Jan. 1999.