



Design of hybrid solar, wind, and Piezoelectric power generation system on Highways

Dr. G.Venkata Suresh Babu

Associate. Professor, EEE, SVIST, Kadapa, Andhra Pradesh – 516001.

ABSTRACT

In today's technology driven world electricity is one of the foremost things for our day-to-day life activities. As we all are oblivious of the fact that the renewable sources of energy are depleting at a lightning-fast rate. So, it's time for us to shift the focus from conventional to non-conventional sources of energy to produce electricity. The output of the electricity produced by non-conventional sources is less than their counterparts. Renewable sources do not have any detrimental effect on the environment. Solar-wind hybrid system is basically an integration of solar plant and a wind energy plant. It will help in providing the uninterrupted power supply. As during bad weather conditions, the production can be shifted from one plant to other with the help of a microcontroller. A microcontroller ensures the optimum utilization of resources and it also increases the efficiency of the combined system as compared to the individual mode of generation. It helps in decreasing the dependence on one single source and makes the system more reliable. The hybrid system can be used for both industrial and domestic applications. In this project we are generating electrical power from non-conventional and conventional sources. All the renewable energy source like Solar energy, wind energy is used to produce electricity in industry. And nonrenewable energy source like piezoelectric generator is also used to produce electricity in industry. In this project a all arrangement is made to produce electricity in single model i.e., why it called multi energy produce system or Hybrid energy system. This invention relates to the natural way of source and other way of source to produce electricity. Among all research directions, such system is possible to implement on any industry successfully.

Keyword Solar Energy, Wind Energy, Renewable Energy, Piezo Generator, Hybrid Power System, Electricity etc.

1. INTRODUCTION

We require electricity for operating almost all the appliances we use in our day-to-day life. So, it has become an indispensable part of our life. Now there are two ways to produce electricity first by using non-renewable sources of energy and second by renewable sources of energy. With increase in population and advancement of technology, consumption of electricity is also increasing exponentially. Simultaneously, we have to increase the production of electricity also in order to meet the demands of growing population. The biggest disadvantage with the usage of conventional resources is that their usage causes pollution due to the production of various pollutants like ash in case of a coal power plant, smoke in case of diesel power plant, radioactive material in case of nuclear power plant. Maintaining these pollutants is not an easy task and it also requires a lot of money. So we have to find some other methods to produce electricity.

The best possible way is by using non-conventional sources of energy. Out of all the possible options available in non-conventional sources of energy, solar and wind are the best methods. As tidal energy can be used only on the sea shores, ocean thermal energy can be used in the middle of the sea and its setup is also very difficult. While solar and wind are available in all the areas of the world and setting up their power plant is also not a cumbersome task. The availability of solar energy is a major concern, as it is available for around 8 hours in a day; on the other hand, wind is available almost for 24 hours. But we can do one thing to make up for that problem by integrating these two together. During foul weather conditions one of them can be used while during normal weather both can be operated together. Renewable energy sources provide clean energy which is present in a sufficient amount on the earth. These renewable sources are obtained from earth, water, sun, plants etc.



These sources are widely used for power generation. Solar and wind power generation is an attractive source because they are eco-friendly. Hybrid system is a mixture of different renewable energy source like solar energy, biomass power, wind etc. In the Hybrid power generation, the generated power is firstly stored in the battery and then it is used to fulfill the demand of energy. Now days wind and solar energy system is growing with a great speed and conventional energy source is depleting day by day and it is going to vanish in coming years. So, we have to search a new energy source which is pollution free, easily available. Sunny days the energy is provided by the sun while on cloudy day the power is supplied by the wind system.

Solar energy is converted with the help of photovoltaic panels whereas the wind energy is converted with the help of wind mill. This hybrid system is made to fulfil the energy demand. By using hybrid system, the transmission cost is reduced in the remote areas, as it can be established there to provide power. The increasingly worldwide problem regarding rapid economy development and a relative shortage of energy, as we all are oblivious of the fact that the renewable sources of energy are depleting at a lightning-fast rate. So, it's time for us to use both conventional and non-conventional sources of energy to produce electricity. The output of the electricity produced by non-conventional sources is less than their counterparts. Renewable sources do not have any detrimental effect on the environment. Solar-wind hybrid system is basically an integration of solar plant, wind plant in industry. It will help in providing the uninterrupted power supply. Renewable sources do not have any detrimental effect on the environment. Solar-wind hybrid system is basically an integration of solar plant, wind plant in industry. It will help in providing the uninterrupted power supply. Also, other non-renewable source like, Piezoelectric module are used to produce the electricity in any industry. whatever the pressure is comes out during transpiration of vehicles Piezoelectric is developed, Due to distinct benefits of Piezoelectric generators, they have become a promising alternative green technology. It helps in decreasing the dependence on one single source and makes the system more reliable. The hybrid system can be used for both industrial and domestic applications.

Problem Statement

Renewable energy is rapidly gaining importance as an energy resource as fossil fuel prices fluctuate. At the educational level, it is therefore critical for engineering and technology students to have an understanding and appreciation of the technologies associated with renewable energy. One of the most popular renewable energy sources is solar energy. Many researches were conducted to develop some methods to increase the efficiency of Photo Voltaic systems (solar panels). One such method is to employ a solar panel tracking system.

Solar tracking enables more energy to be generated because the solar panel is always able to maintain a perpendicular profile to the sun's rays. Development of solar panel tracking systems has been ongoing for several years now. As the sun moves across the sky during the day, it is disadvantageous to have the solar panels track the location of the sun, such that the panels are always perpendicular to the solar energy radiated by the sun. This will tend to maximize the amount of power absorbed by PV systems. It has been estimated that the use of a tracking system, over a fixed system, can increase the power output by 30% - 60%. The increase is significant enough to make tracking a viable proposition despite of the enhancement in system cost. It is possible to align the tracking heliostat normal to sun using electronic control by a micro controller. Design requirements are:

- 1) During the time that the sun is up, the system must follow the sun's position in the sky.
- 2) This must be done with an active control; timed movements are useful. It should be totally automatic and simple to operate.

Main Statement:

1. Develop a mechanism that would develop the electric energy from piezo generator module.
2. Add other sources like, Horizontal axis wind turbines to maximize electrical output.
3. Also add the solar system to produce electricity.
4. Fabricate the model of the same which would able to show the characteristics of systems and working according to need.

Objective:

1. To design and construct a piezo generator system to generate the electricity form pressure
2. To design wind power system to generate electricity air flow.
3. To design the solar system which can absorb maximum amount of sunlight.
4. To minimize the cost of installation and operation providing higher reliability.
5. Combine all this system to make hybrid power generation, which will help to provide maximise energy to



Industrial Engineering Journal

ISSN: 0970-2555

Volume : 50, Issue 3, No. 1, March 2021

any industry or place.

2. METHODOLOGY

The global need to conserve the planet, energy and satisfy the continuous demand for electrical energy generation has led us to explore new sources of sustainable energy such as solar and wind as well as other sustainable energy sources.

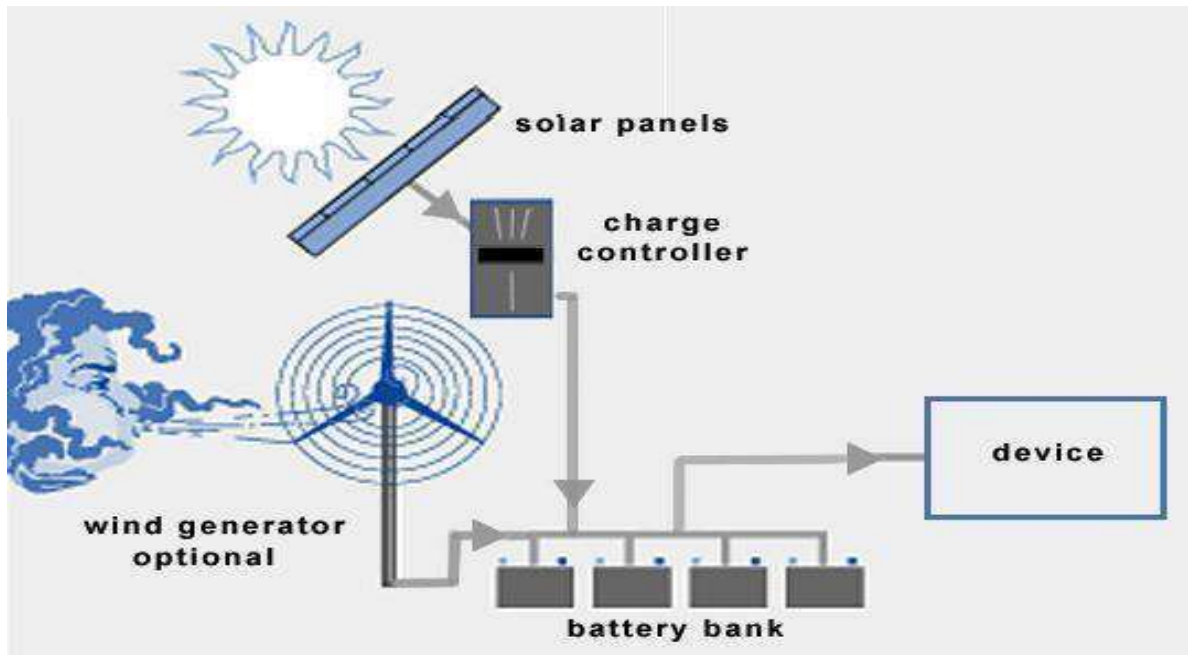

Fig.1. Schematic of a photovoltaic Hybrid System.

The photovoltaic wind hybrid system as shown in Figure 1, is a system that can be integrated into two or more renewable sources of energy (solar-thermal, geothermal, biomass, hydro etc.). Those systems are integrated to provide electricity or heat, or both, to supply the demand, and taking advantage of the availability of solar and wind energy, in places where these two sources of renewable energies are complementing to each other. Interested readers are advised to consult reference on the subject. The wind energy depends on the conditions of the wind and ambient conditions, the wind turbine is recommended where average annual wind speeds are higher than 6.5m/s at a height of 50m. On the other hand, photovoltaic energy has been one of the renewable energy sources with rapid technological growth. It has been reported that its annual production of solar panels grew tenfold from 1990 to 2003 (50 MW to 500 MW), and is in constant growth.

The function of the photovoltaic solar panel is simple; solar panels receive solar radiation form of light and thus generate a potential difference at its ends in the form of continuous current. These panels are normally connected in parallel or series depending on the power and load requirements. It should be noted that a hybrid system such as solar/wind hybrid must have load/charge controller which controls the wind turbine and solar panel at the same time and allows the conversion and transformation of wind and solar energies into electrical energy and consequently, stores this electrical energy in the batteries bank. It should be also noted that the driver of the hybrid Wind/Solar is the most important part in the out-of-network system, due to the control that allows the operation of all the hybrid system. This paper is intended to discuss the construction and implementation of a system for the measurement of electrical power parameters such as amperage and voltage of the hybrid system; photovoltaic solar-wind, to evaluate and analyze the system performance. With the rapid increase in population and economic development, the problems of the energy crisis and global warming effects are today a cause for increasing concern. The utilization of renewable energy resources is the key solution to these problems. Solar energy is one of the primary sources of clean, abundant and inexhaustible energy that not only provides alternative energy resources, but also improves environmental pollution. Solar tracking is the most appropriate technology to enhance the electricity production of a PV system. To achieve a high degree of tracking accuracy, several approaches have been widely investigated. Generally, they can be classified as either open-loop tracking types based on solar movement mathematical models or closed-loop tracking types using sensor-based feedback controllers. In the open-loop tracking approach, a



Industrial Engineering Journal

ISSN: 0970-2555

Volume : 50, Issue 3, No. 1, March 2021

tracking formula or control algorithm is used. Referring to the literature, the azimuth and the elevation angles of the



Sun were determined by solar movement models or algorithms at the given date, time and geographical information. The control algorithms were executed in a microprocessor controller. In the closed-loop tracking approach, various active sensor devices, such as charge couple devices (CCDs) or light dependent resistors (LDRs) were utilized to sense the Sun's position and a feedback error signal was then generated to the control system to continuously receive the maximum solar radiation on the PV panel.

Solar tracking approaches can be implemented by using single-axis schemes, and vertical axis structures for higher accuracy systems. In general, the single-axis tracker with one degree of freedom follows the Sun's movement from the east to west during a day while a single-axis tracker also follows the elevation angle of the Sun. In recent years, there has been a growing Volume of research concerned with vertical axis solar tracking systems. However, in the existing research, most of them used two stepper motors to perform vertical axis solar tracking. With two tracking motors designs, two motors were mounted on perpendicular axes, and even aligned them in certain directions. In some cases, both motors could not move at the same time. Furthermore, such systems always involve complex tracking strategies using microprocessor chips as a control platform. In this work, employing a vertical axis with only single tracking motor, an attempt has been made to develop and implement a simple and efficient control scheme. The two axes of the Sun tracker were allowed to move simultaneously within their respective ranges. Utilizing conventional electronic circuits, no programming or computer interface was needed. Moreover, the proposed system used a stand-alone PV inverter to drive motor and provide power supply. The system was self-contained and autonomous. Experiment results have demonstrated the feasibility of the tracking PV system and verified the advantages of the proposed control implementation. Man has needed and used energy at an increasing rate for his sustenance and well-being ever since he came on to the earth a few million years ago. Solar energy promises of becoming a dependable energy source without any polluting effects. Solar energy can be used both directly and indirectly. It can be used directly in a variety of thermal applications like heating water or air, drying, distillation and cooking. The heated fluids can in turn be used for applications like power generation or refrigeration. A second way in which it is converted to electric energy is by indirectly causing the winds to blow, plants to grow, rain to fall and temperature differences to occur from the surface to the bottom of oceans. Useful energy can be obtained for commercial and non-commercial purposes through all these renewable sources.

Electricity has helped in reducing physical efforts to a very large extent, but, the way in which it is produced is quite a matter of concern. Even today, most of the electricity that we use is produced through conventional methods. These conventional methods commonly use fossil fuels to produce electricity. Not only are these methods expensive, but also cause grave damage to the environment. The use of fuels for the generation of electricity results in increased costs and emissions of hazardous pollutants. The only alternative is a new method that is not only cheap and efficient, but also eco-friendly.

The Solar Tracking - Vertical Axis Wind Turbine System is capable of satisfying both these requirements. In addition to being eco-friendly, it is also relatively cheaper when compared to the conventional methods of electricity generation. This turbine uses both Solar and Wind Energies to generate electricity. So, we have two efficient and inexhaustible sources for uninterrupted generation of electricity. The system has two basic components – one for generation of electricity through Solar Energy and another one for generation from Wind Energy. Even in the case of absence of either of the two sources, the other remaining source could be used to supplement the absence of the former. Due to all these features, the Solar-Vertical Axis Wind Turbines could be considered suitable for replacing the existing old means of electricity generation. Because, not only are they cheaper, but also economic and highly efficient. These turbines are gaining ground day by day and hopefully will be helpful in making us achieve the long sought-after goal of green and clean energy.

Scope of the Project

1. It is the design method for maximum conversion efficiency of a turbine for delivering the maximum power to a load, battery, in the case of a standalone solar-wind system.
2. Saves space.
3. It doesn't require fuel

3. PROJECT DESIGN AND IMPLEMENTATION

System Function

We require electricity for operating almost all the appliances we use in our day-to-day life. So it has become an indispensable part of our life. Now there are two ways to produce electricity first by using non-renewable sources of energy and second by renewable sources of energy. With increase in population and advancement of technology, consumption of electricity is also increasing exponentially. Simultaneously, we have to increase the production of electricity also in order to meet the demands of growing population. The biggest disadvantage with the usage of conventional resources is that their usage causes pollution due to the production of various pollutants like ash in case of a coal power plant, smoke in case of diesel power plant, radioactive material in case of nuclear power plant. Maintaining these pollutants is not an easy task and it also requires a lot of money. So we have to find some other methods to produce electricity.

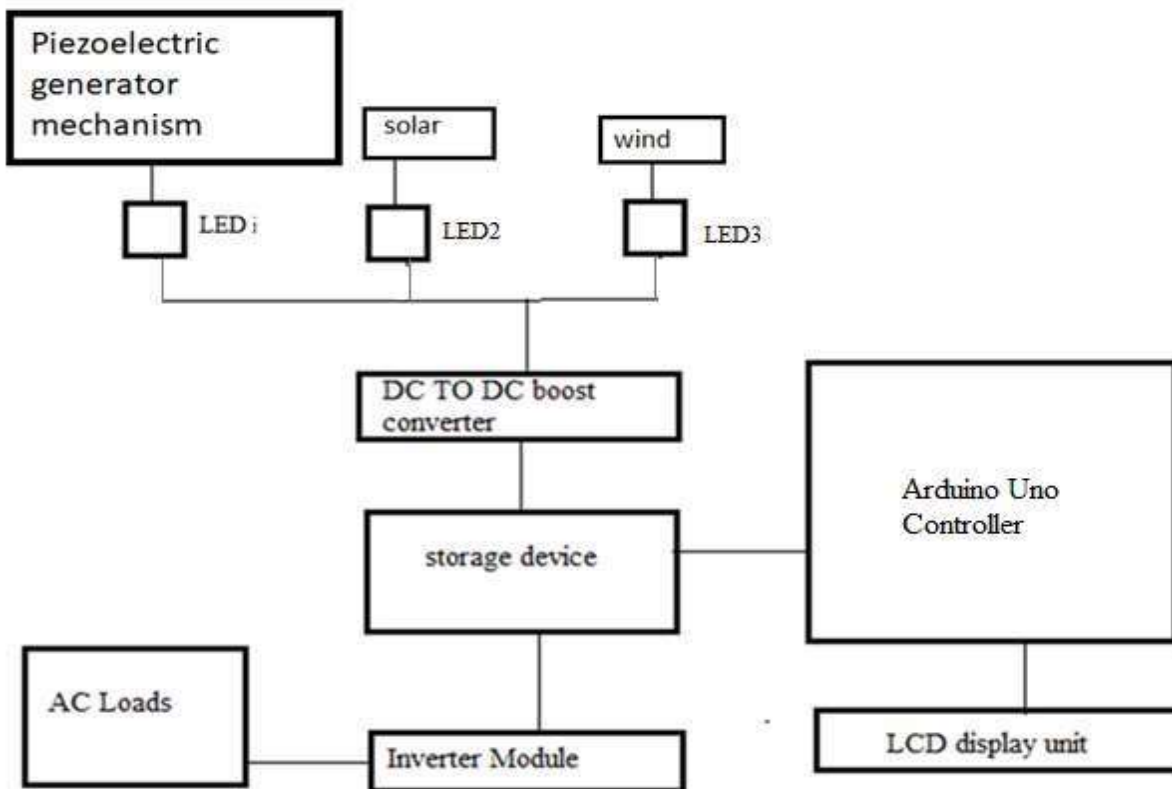

Fig. 2. Block Diagram of Hybrid System Model

Working

Hybrid energy is the combination of more than one energy source. Combination of solar and wind with piezo generator is better among all the other combination. Whenever force is applied on piezoelectric crystals that force is converted to electrical energy which can be used to drive dc loads and that minute voltage which is stored in the lead acid battery. The battery is connected to the inverter. This inverter is used to convert the 12-volt D.C to the 230-volt A.C. This 230-volt A.C voltage is used to activate the loads. We are using conventional battery charging unit also for giving supply to the circuitry. Here we are using ATmega 328p Controller to display though LED display, it show the amount of voltage and Current status. In this system wind turbine can be used to produce electricity when wind is available and solar energy panels are used when solar radiations are available. Power can be generated by both the sections at the same time also. The usage of batteries is to provide uninterrupted power supply. The microcontroller is used in the system to control the switching between the converters with the help of a driver circuit. A charge controller/converter is used to control the power supply of solar panels.

The best possible way is by using non-conventional sources of energy. Out of all the possible options available in non-conventional sources of energy, solar and wind are the best methods. As tidal energy can be used only on the sea shores, ocean thermal energy can be used in the middle of the sea and its setup is also very difficult. While solar and wind are available in all the areas of the world and setting up their power plant is also not a cumbersome task. The availability of solar energy is a major concern, as it is available for around 8 hours in a day; on the other hand wind is available almost for 24 hours. But we can do one thing to make up for that problem by integrating these two together. During foul weather conditions one of them can be used while during normal weather both can be operated together. So in this paper we will be describing a solar-wind hybrid power system.

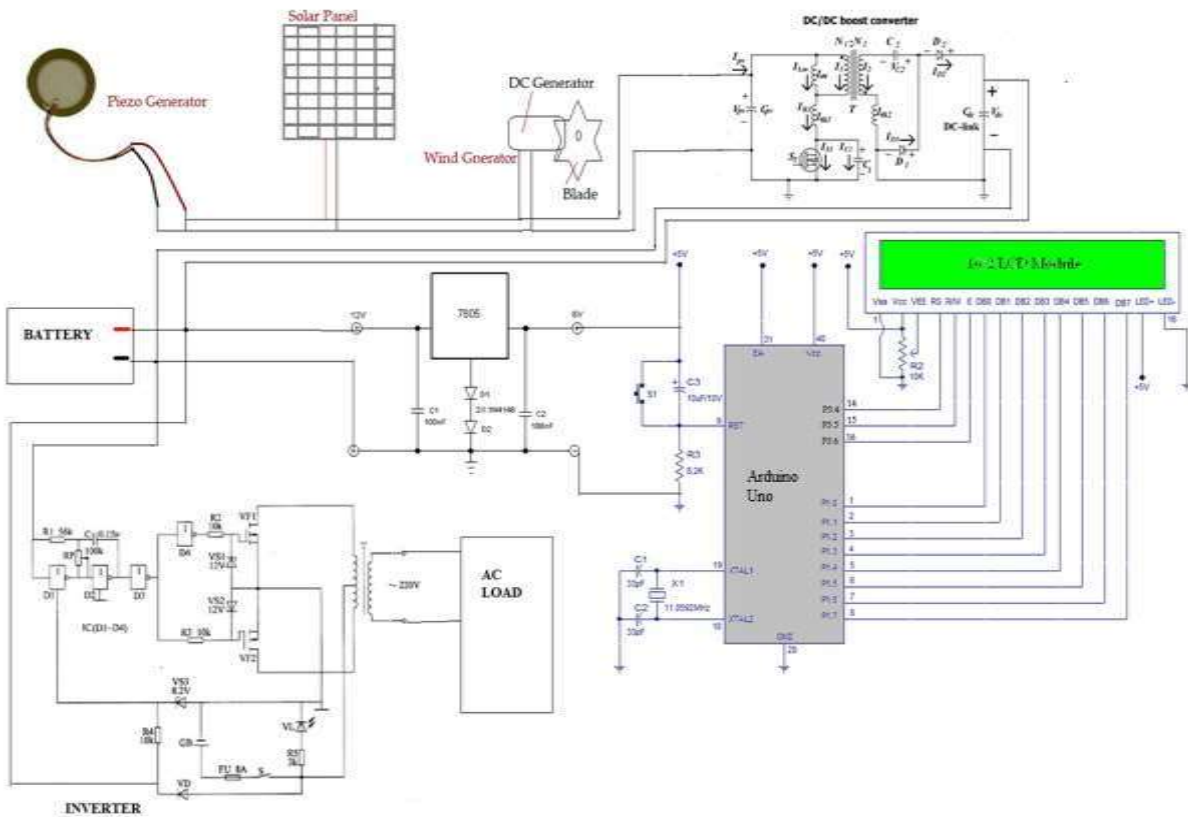

Fig. 3. Circuit diagram of the proposed architecture

Now we have become even more interested in usage of renewable energy sources as an alternative method of producing electricity. Hybrid systems are basically an integration of solar panels and wind turbine, the output of this combination is used to charge batteries, this stored energy can then be transmitted to local power stations. In this system wind turbine can be used to produce electricity when wind is available and solar energy panels are used when solar radiations are available. Power can be generated by both the sections at the same time also. The usage of batteries is to provide uninterrupted power supply.

This system requires high initial investment. But the reliability, long-life span and less maintenance make up for that disadvantage. The power output of the wind turbine is AC which is converted to DC with the help of a rectifier. The voltage can be stepped up or stepped down with the help of a 'SEPIC' converter which uses MOSFET switching. The Arduino Uno 328p controller is used in the system to control the switching between the converters with the help of a driver circuit. A charge controller/converter is used to control the power supply of solar panels. In industry Sun rays is easily available at top of roof i.e. Solar panel is used to extract the solar energy into electric energy. Also, wind energy is used at the top of roof to produce electricity. And while transporting vehicles, goods or employees walking pressure is created on surface so piezoelectric generator is used to produce electricity from it. In this way all the sources from any industry is covered up to produce electricity. This is research-oriented concept and we try to bring new technology and innovation to produce electricity. Hybrid energy is the combination of more than one energy source.

1. Wind Energy

When air flows then it is having some kinetic energy with it which is known as wind energy. This kinetic energy is converted into mechanical energy by the wind turbine, which is used to rotate the shaft of the generator and then electricity is produced. The cost of generation of electricity is quite less. The initial investment of the system varies depending on the type of turbine used. The best part about producing electricity with the help of wind energy is that wind is available for almost 24 hours in day, so there will not be any discontinuous production of electricity. The output varies with the speed of the wind.

2. Piezo Energy

The piezoelectric effect converts kinetic energy in the form of vibrations or shocks into electrical energy. Piezoelectric generators (energy harvesters) offer a robust and reliable solution by converting normally wasted vibration energy in the environment to usable electrical energy. They are ideal in applications that need to charge a battery, super capacitor, or directly power remote sensor systems.

A piezoelectric sensor is a sensor that generates a mechanical strain when an external force is applied or a deformation occurs when a voltage is applied to the sensor. The piezoelectric sensor is applied in various purposes in many industries and used widely such as medical industries, automobile industries, and information communication industry. This piezoelectric sensor determines the energy level from the external force condition, and it is expected to collect high energy.

3. Hybrid Systems

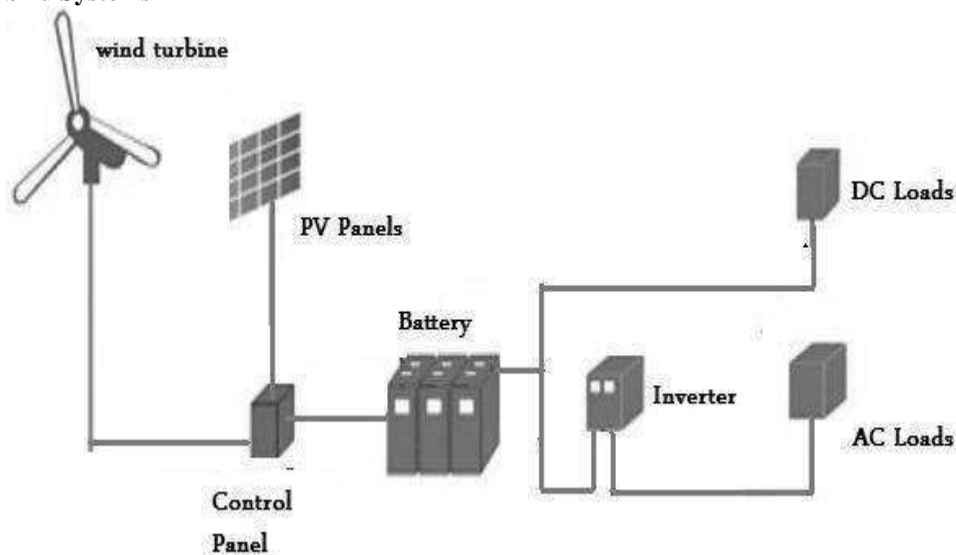

Fig.4. Hybrid Systems

Now we have become even more interested in usage of renewable energy sources as an alternative method of producing electricity. Hybrid systems are basically an integration of solar panels and wind turbine, the output of this combination is used to charge batteries, this stored energy can then be transmitted to local power stations.

In this system wind turbine can be used to produce electricity when wind is available and solar energy panels are used when solar radiations are available. Power can be generated by both the sections at the same time also. The usage of batteries is to provide uninterrupted power supply. This system requires high initial investment. But the reliability, long-life span and less maintenance make up for that disadvantage. The power output of the wind turbine is AC which is converted to DC with the help of a rectifier. The voltage can be stepped up or stepped down with the help of a 'SEPIC' converter which uses MOSFET switching. The microcontroller is used in the system to control the switching between the converters with the help of a driver circuit. A CUK converter is used to control the power supply of solar panels.



4. RESULTS AND DISCUSSIONS

Overall power generated by system is the summation of the power generated by the solar PV panel and power generated by the wind turbine. Mathematically, it can be represented as,

$$PT = NW * Pw + Ns * PS \text{-----(1)}$$

Where,

Total power generated= PT, Power generated by wind turbines= PW, Power generated by solar panels= PS, No. of wind turbine = NW, No of solar panels used= NW

A. Calculations for wind energy:

The power generated by wind energy is given by, Power = (density of air * swept area * velocity cubed)/2

$$PW = \frac{1}{2} \rho (AW) (V)^3 \text{----- (2)}$$

Where,

P is power in watts (W) , ρ is the air density in kilograms per cubic meter (kg/m³) AW is the swept area by air in square meters (m²) V is the wind speed in meters per second (m/s).

B. Calculations for solar energy

To determine the size of PV modules, the required energy consumption must be estimated. Therefore, the power is calculated as

$$PS = Ins (t) * AS * Eff(pv) \text{----- (3)}$$

Where,

Ins (t) = isolation at time t (kw/ m2), AS = area of single PV panel (m2), Effpv = overall efficiency of the PV panels and dc/dc converters.

Overall efficiency is given by, $Eff(pv) = H * PR \text{-----(4)}$

Where,

H = Annual average solar radiation on tilted panels, PR = Performance ratio, coefficient for losses.

C. Cost

The total cost of the solar-wind hybrid energy system is depend upon the total no of wind turbines used and total no of solar panels used. Therefore the total cost is given as follows

Total cost= (No. of Wind Turbine * Cost of single Wind Turbine) + (No. of Solar Panels * Cost of single Solar Panel) + (No. of Batteries used in Battery Bank * Cost of single Battery)

$$CT = (NW * CWT) + (NS * CSP) + (NB * CB) \text{-----(5)}$$

Where,

CT is the total cost in Rs, CWT is the cost of single wind turbine, CSP is the cost of single solar panel in Rs CB is the Cost of single Battery in Rs, NW is the number of wind turbine used, NS is the number of solar panels used, NB is the number of Batteries used in Battery Bank.

SOLAR ANALYSIS



Fig.5. Avg solar radiation

The above graph shows the variation of the solar radiation in different months of the year. By using graph, we can say that solar radiation is maximum in the month of may and minimum in the month of October of that particular area.

WIND SPEED ANALYSIS

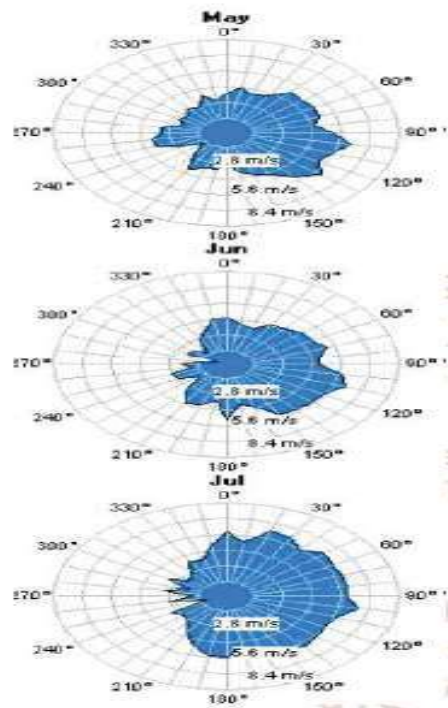

Fig.6. Wind Analysis

The above fig shows the wind speed of the month of may, june and july. As we can see clearly the wind speed scattering varies within 3 months.

Analysis Method

A. Windowgrapher: Windowgrapher is a wind data analysis program. It reads raw data related to wind, produces variety of graphs and provide tools for quality control of data.

B. Homer : It means “hybrid optimization Model for energy Renewable”. This software contains a number of energy component models and evaluates suitable technology based on cost and availability of resources. The simulation of HOMER is done for both on grid and off grid design.



Figure: Hardware Kit



HYBRID ENERGY SYSTEM

Hybrid energy is the combination of more than one energy source. Combination of solar and wind is better among all the other combination.

Advantages with Hybrid System

- In rainy and winter season the amount of solar radiation is not sufficient than in this season energy is fulfilled by wind energy system.
- Due to variation in weather condition when there is lack of wind energy than the power is supplied by the solar panels.
- Low operating cost and maintenance cost makes it economical.
- Used in any location whether it is remote area or populated area.
- Highly efficient power generation
- Solar- and wind-powered sites benefits the environment as it will reduce the carbon and other harmful emission is about 90% in environments.

Need of the System

- The utilization of waste energy of foot power with human motion is very important for highly populated countries.
- India and China where the roads, railway stations, temples, etc. are all over crowded and millions of people move around the clock.

Advantages

- Power generation is simply walking on step.
- No need fuel input.
- This is a Non-conventional system.
- No moving parts - long service life.
- Self-generating - no external power required.
- Compact yet highly sensitive.

Applications

- Foot step generated power can be used for agricultural, home applications, street-lighting.
- Foot step power generation can be used in emergency power failure situations.
- Also, with the solar and wind power generation added efficiency in power generation
- Railways, Metros, Bus stop, Rural Applications etc.
- Distributed power generation
- Hospital, Hotels, Guesthouse etc.
- Street lighting.
- Transmission and communication Tower and many more application.

5. CONCLUSIONS

Hybrid energy is the combination of more than one energy source. Combination of solar and wind with piezo generator is better among all the other combination. Developing foot step power generation system along with solar and wind is one of the most convenient and effective solution for producing. Depending on the requirement its setup can be decided. All the people in this world should be motivated to use such resources to produce electricity in order to make them self-reliable to some extent. Long life span, less maintenance is some of its plus point. It just requires some high initial investment. As we come to know that the hybrid system has a more per unit production cost but uses the available resources in a efficient way. This Hybrid system is also able to recover from any accidental or undesired situation. Also, hybrid system is able to fulfill the energy of remote and rural areas. So, it is clear that Hybrid system is the better choice.



REFERENCES

- [1]. A. Adejumobi, S.G. Oyagbinrin, F. G. Akinboro & M.B. Olajide, "Hybrid Solar and Wind Power: An Essential for Information Communication Technology Infrastructure and people in rural communities", IJRRAS, Volume 9, Issue 1, October 2011, pp 130-138.
- [2] Kavita Sharma, Prateek Haksar "Designing of Hybrid Power Generation System using Wind Energy- Photovoltaic Solar Energy- Solar Energy with Nanoantenna" International Journal of Engineering Research And Applications (IJERA) Vol. 2, Issue 1, Jan-Feb 2012, pp.812-815 .
- [3] Sandeep Kumar, Vijay Kumar Garg, "A Hybrid model of Solar-Wind Power Generation System", International Journal of Advanced Research in Electrical, Electronics and Instrumentation Engineering (IJAREEIE), Vol. 2, Issue 8, August 2013, pp. 4107-4016.
- [4] International Journal of Electronic and Electrical Engineering. ISSN 0974-2174, Volume 7, Number 5 (2014), pp. 535542 © International Research Publication House <http://www.irphouse.com> Hybrid Renewable Energy System: A
- [5] Arjun A. K., Athul S., Mohamed Ayub, Neethu Ramesh, and Anith Krishnan, "Micro-Hybrid Power Systems – A Feasibility Study", Journal of Clean Energy Technologies, Vol. 1, No. 1, January 2013, pp27-32.
- [6] Khurshid hasan, Kaniz fatima, Md. Sohel mahmood, "Feasibility Of hybrid Power generation over Wind and Solar Standalone System", 5 International Power Engineering and Optimization Conference 2011.



- [7] Ashish S. Ingole , Prof. Bhushan S. Rakhode (2015) Hybrid Power Generation System Using Wind Energy and Solar Energy, International Journal of Scientific Research Publications, volume 5, issue 3, March 2015 ,ISSN 2250-3153.
- [8] M.Khalid and A. V. Savkin, “Optimal Hybrid Wind Solar system for Matching Renewable Power Generation With Demand” 2014 IEEE 978-1-4799-2837-8/14.
- [9] Vaibhav J. Babrekar, Shraddha D. Bandawar,”review paper on hybrid solar wind power generator”,International journal of computer applications,2017
- [10] M. Khalid and A. V. Savkin, “A method for shortterm wind power prediction with multiple observation points,” IEEE Transactions on Power Systems, vol. 27, no. 2, pp. 579–586, 2012.
- [11] Sowjanya M. N,Stafford Michahia, Mahanthesha U, and Nagalakshmi T. S,"Lung Cancer Detection in Chest X - Ray Image". – 20 IEEE
- [12] Dr. H S Mohan and Mahanthesha U, “Human action Recognition using STIP Techniques”, International Journal of Innovative Technology and Exploring Engineering (IJITEE) ISSN: 2278-3075, Volume-9 Issue-7, May 2020
- [13] Mahanthesha U, Dr. H S Mohana “Identification of Human Facial Expression Signal Classification Using Spatial Temporal Algorithm” International Journal of Engineering Research in Electrical and Electronic Engineering (IJEREEE) Vol 2, Issue 5, May 2016
- [14] Pavithra S, Mahanthesha U, Stafford Michahial, Dr. M Shivakumar, “Human Motion Detection and Tracking for Real-Time Security System”, International Journal of Advanced Research in Computer and Communication Engineering ISO 3297:2007 Certified Vol. 5, Issue 12, December 2016.