

ARTIFICIAL NEURAL NETWORK BASED MPPT FOR SOLAR PV BATTERY POWERED BLDC MOTOR: A COMPREHENSIVE REVIEW

Mr. Rajesh kumar Gupta, M.Tech scholar, Dept.Of Electrical &Electronics Engineering, Technocrats institute of Technology, Bhopal

Dr Anula khare, Professor, Dept.Of Electrical &Electronics Engineering, Technocrats institute of Technology, Bhopal

Dr Vasant Acharya Associate Professor, Dept.Of Electrical &Electronics Engineering, Technocrats institute of Technology, Bhopal

Abstract:

This paper presents a comprehensive review of the application of Artificial Neural Networks (ANNs) in Maximum Power Point Tracking (MPPT) control for solar photovoltaic (PV) systems integrated with battery energy storage and brushless DC (BLDC) motors. The review focuses on research advancements within the last decade, highlighting the advantages of ANN-based MPPT over traditional methods like Perturb and Observe (P&O) and Incremental Conductance (INC). Various ANN architectures, including Feedforward Neural Networks (FFNNs), Recurrent Neural Networks (RNNs), and hybrid approaches are discussed, along with their strengths and limitations. The paper also explores the integration of ANN-based MPPT controllers with Battery Management Systems (BMS) and the significance of training algorithms and data preprocessing techniques. Experimental results and comparative studies are analyzed, demonstrating the superior performance of ANN-based MPPT in terms of convergence speed, efficiency, and robustness. Finally, the review outlines promising future research directions, including the exploration of deep learning architectures, reinforcement learning, low-cost hardware implementations, and integration with Internet of Things (IoT) technologies.

Keywords: -

Artificial Neural Networks (ANN), Brushless DC (BLDC) motor, Maximum Power Point Tracking (MPPT), Battery Management System (BMS), Deep learning, Internet of Things (IoT)

1. Introduction

The increasing global energy demand and the urgent need to mitigate the environmental impact of fossil fuels have driven significant interest in renewable energy technologies. Solar photovoltaic (PV) systems have emerged as a promising solution, offering a clean and sustainable way to generate electricity. However, the intermittent nature of solar radiation presents challenges in effectively harnessing this energy source. [1]

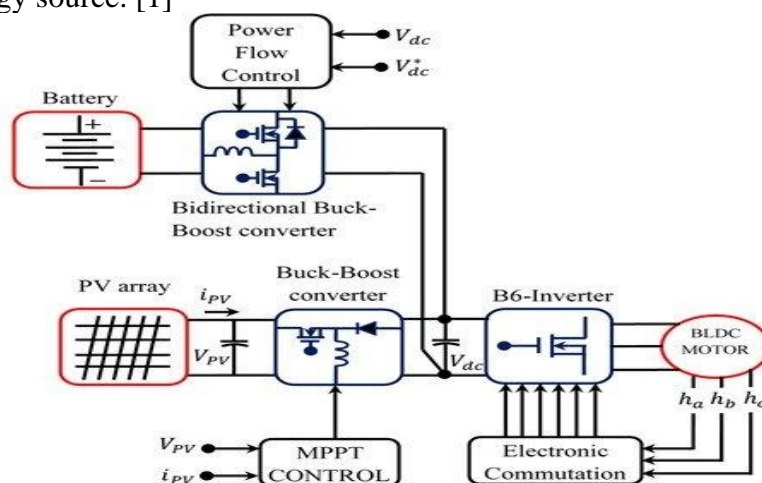

Figure 1- Solar PV System with A Battery and BLDC Motor

To maximize power extraction from solar PV arrays, efficient Maximum Power Point Tracking (MPPT) algorithms are essential. These algorithms dynamically adjust the operating point of the PV array to ensure it consistently operates at the maximum power point (MPP), where the product of voltage and current is maximized. Traditional MPPT techniques, such as Perturb and Observe (P&O) and Incremental Conductance (INC), often exhibit limitations like slow convergence, oscillations around the MPP, and sensitivity to environmental fluctuations, impacting overall system efficiency. [2, 3]

2. Artificial Neural Networks for MPPT

Architecture of Artificial Neural Network

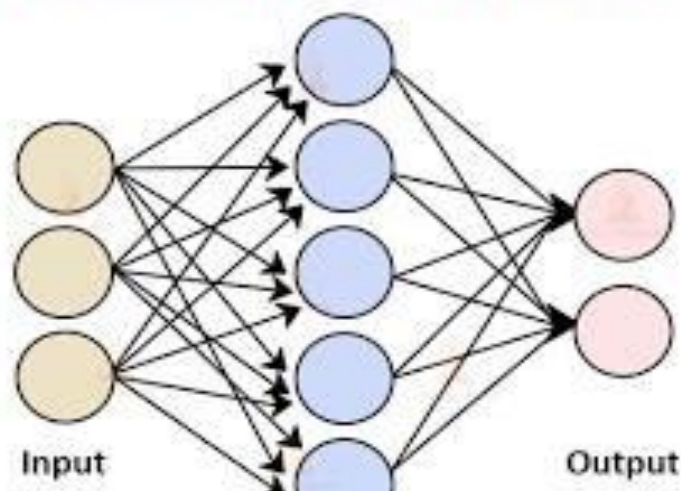

Figure 2-Artificial Neural Network Architecture

Artificial Neural Networks (ANNs), inspired by the human brain, offer a compelling alternative for MPPT control. Their ability to learn complex nonlinear relationships, adapt to changing conditions, and exhibit rapid convergence makes them well-suited for this application. [4, 5] Integrating ANNs with solar PV systems, particularly those coupled with battery energy storage and brushless DC (BLDC) motors, presents a promising pathway toward achieving high efficiency, reliability, and grid stability. BLDC motors are widely used due to their high efficiency, power density, and low maintenance requirements. [6, 7]

This review paper provides a comprehensive overview of ANN-based MPPT for solar PV-battery-BLDC motor systems, focusing on recent advancements and research findings. It delves into the fundamental principles of ANNs, explores various architectures employed for MPPT control, and discusses the integration with battery management systems. Furthermore, it analyzes the impact of training algorithms, data preprocessing techniques, and experimental results, providing a comparative analysis with conventional methods. Finally, the paper concludes with a discussion on future research directions and the potential for further advancements in this field.

2. Background

2.1 Solar PV Technology

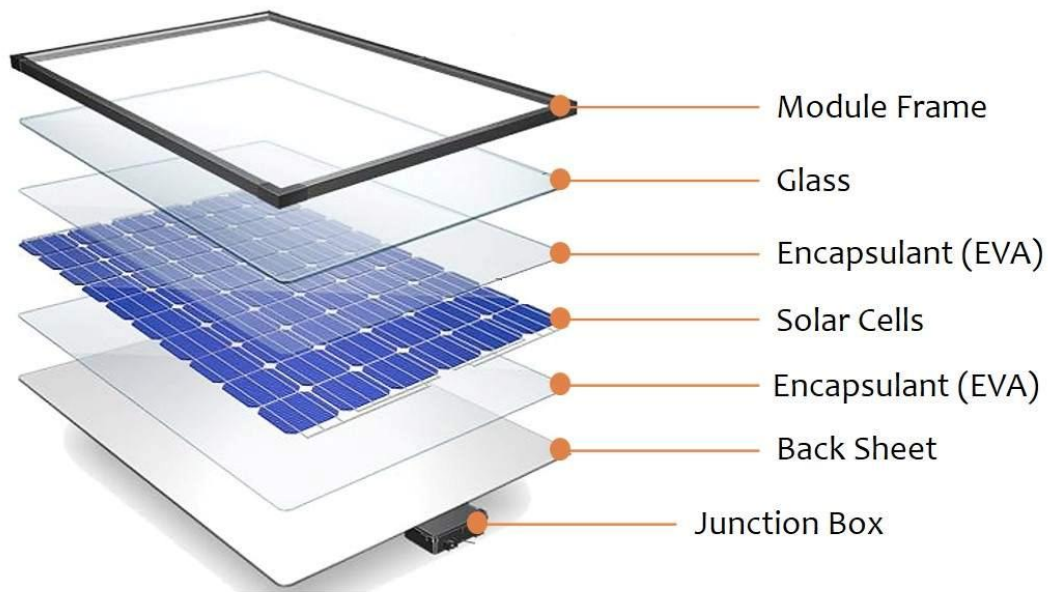

© EU-India TCP, 2020

Figure 3-solar PV panel

Solar PV technology converts sunlight into electricity through the photovoltaic effect. When photons strike a photovoltaic cell, they excite electrons within the semiconductor material, generating an electrical current. The performance of a PV module is influenced by factors like solar irradiance, temperature, and module characteristics. [1]

The power-voltage (P-V) characteristic of a PV module exhibits a nonlinear relationship with a single peak, representing the Maximum Power Point (MPP). At the MPP, the product of voltage and current is maximized, resulting in the highest power output.

2.2 BLDC Motor

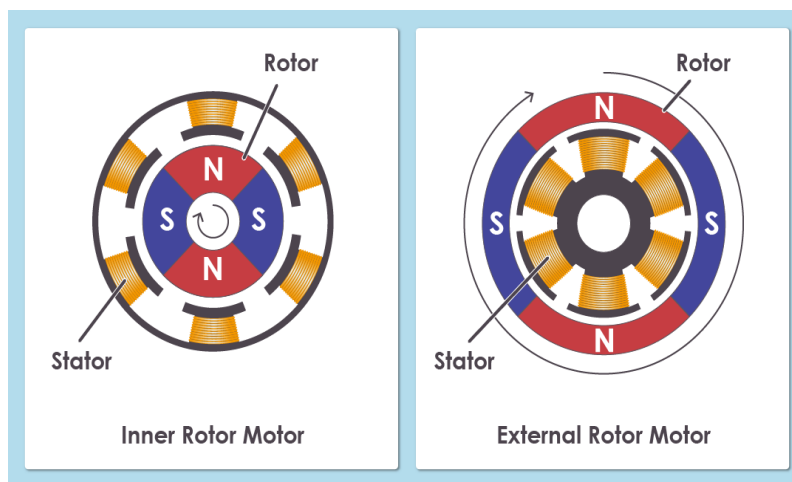

Figure 4- BLDC Motor

Brushless DC (BLDC) motors have gained popularity due to their high efficiency, high power density, and low maintenance requirements. They operate based on electronically commutated operation, where electronic switches control the current flow to the motor windings, enabling precise control of speed, torque, and direction. [6]

2.3 MPPT Algorithms

MPPT algorithms adjust the operating point of the PV array to track the MPP under varying conditions. Common conventional algorithms include:

- **Perturb and Observe (P&O):** Introduces small perturbations to the operating point and observes the resulting change in power output to determine the direction of the MPP. [2]

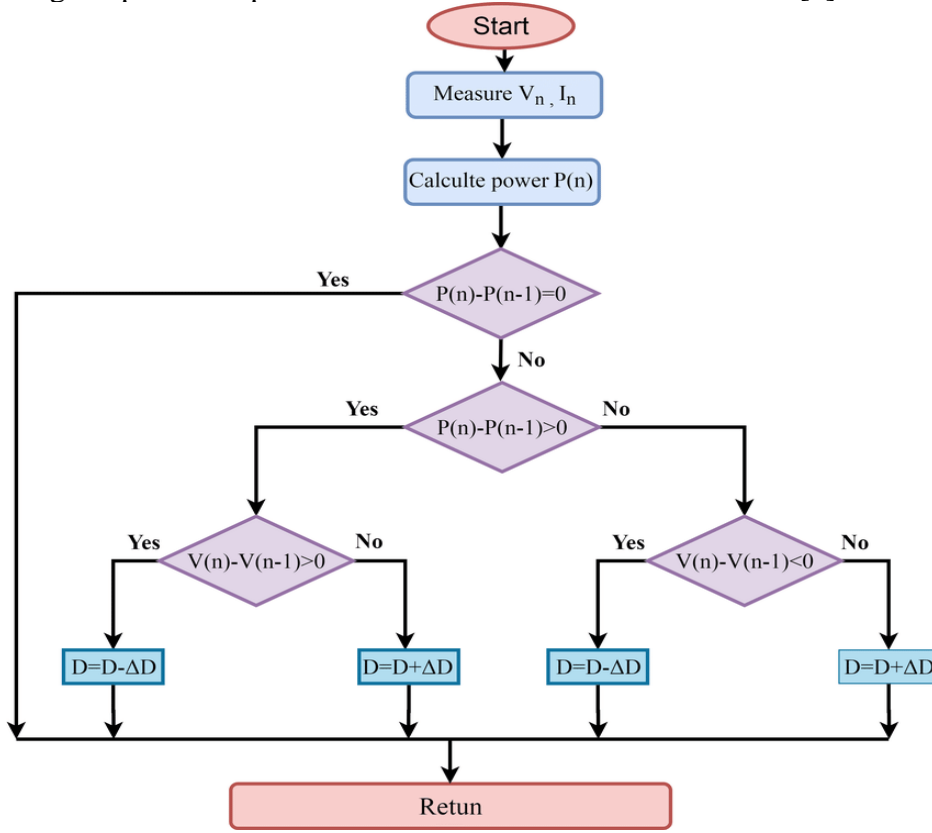

Figure 5-P&O Algorithm

- **Incremental Conductance (INC):** Compares the incremental changes in voltage and current to predict the direction of the MPP. [3]

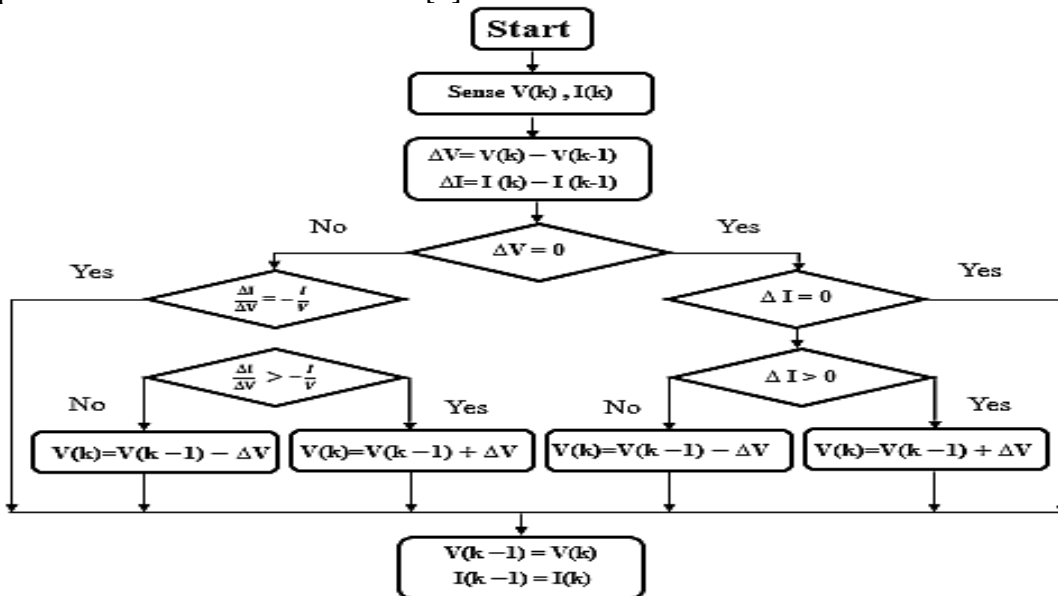

Figure 6-INC algorithm

- **Hill Climbing:** Directly searches for the peak power output by moving in the direction of increasing power.

While these methods are effective in certain scenarios, they often suffer from limitations like slow convergence, oscillations around the MPP, and sensitivity to parameter variations.

2.4 ANN Fundamentals

Artificial Neural Networks (ANNs) are computational models inspired by biological neural networks. They consist of interconnected nodes (neurons) organized in layers:

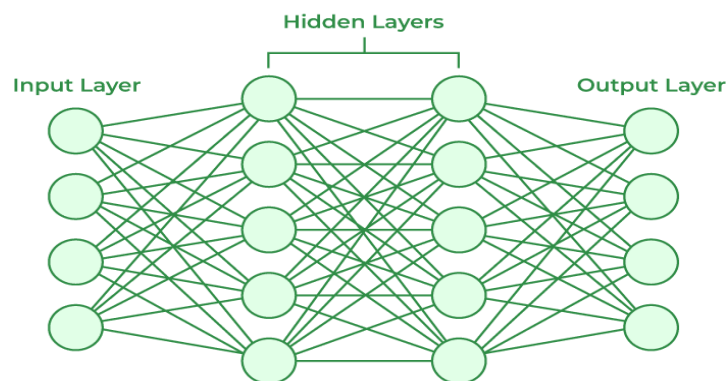

Figure 7-artificial neural network

- **Input Layer:** Receives information from external sources.
- **Hidden Layers:** Process the input information, extracting features and identifying relationships.
- **Output Layer:** Produces the final output of the network.

ANNs learn by adjusting the weights associated with the connections between neurons based on the presented data and the desired output. This learning process typically involves training the network on a large dataset of input-output pairs. [8]

2.5 Advantages of ANN-based MPPT

ANNs offer several advantages for MPPT control:

- **Fast Convergence:** ANNs can converge to the MPP much faster than traditional algorithms, minimizing energy losses.
- **Robustness:** ANNs are robust to noise and uncertainties, ensuring reliable operation under challenging conditions.
- **Adaptability:** ANNs can adapt to changing environmental conditions and load variations, maintaining optimal performance.
- **Nonlinearity Handling:** ANNs excel at modeling nonlinear relationships, enabling accurate MPP tracking.

3.1 Feedforward Neural Networks (FFNNs)

FFNNs are the most commonly used ANN architecture for MPPT. They consist of an input layer, one or more hidden layers, and an output layer. The input layer receives information about system variables like solar irradiance, temperature, and PV array voltage and current. The hidden layers process this information, and the output layer generates the control signal for the DC-DC converter.

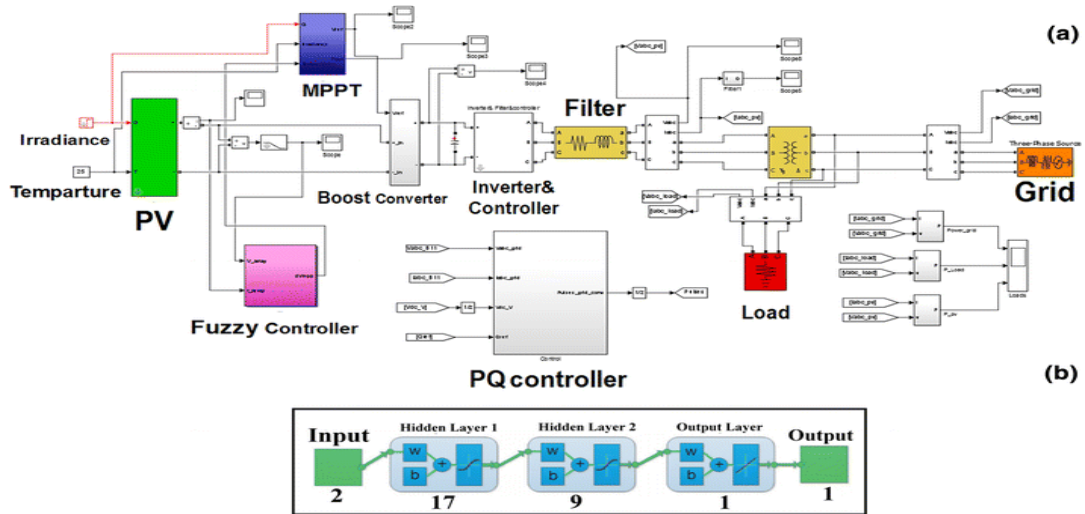

Figure 8-Feedforward Neural Network architecture for MPPT

3.2 Recurrent Neural Networks (RNNs)

RNNs are designed to handle sequential data and capture temporal dependencies. They incorporate feedback connections, allowing information to persist over time. In MPPT, RNNs can predict future MPP trajectories and improve tracking accuracy. Popular RNN architectures include Long Short-Term Memory (LSTM) networks and Gated Recurrent Units (GRUs).

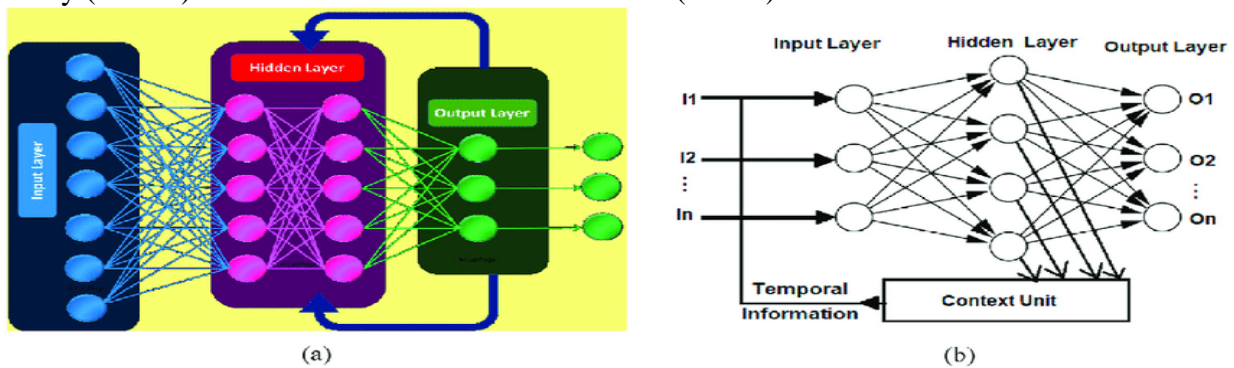

Figure 9-Recurrent Neural Network architecture for MPPT

3.3 Hybrid Approaches

Hybrid approaches combine the strengths of different ANN architectures or integrate ANNs with other intelligent control techniques, such as fuzzy logic. These approaches aim to enhance performance by leveraging the complementary strengths of different methodologies. Examples include ANN-Fuzzy Logic Systems and Neuro-Evolutionary Algorithms.

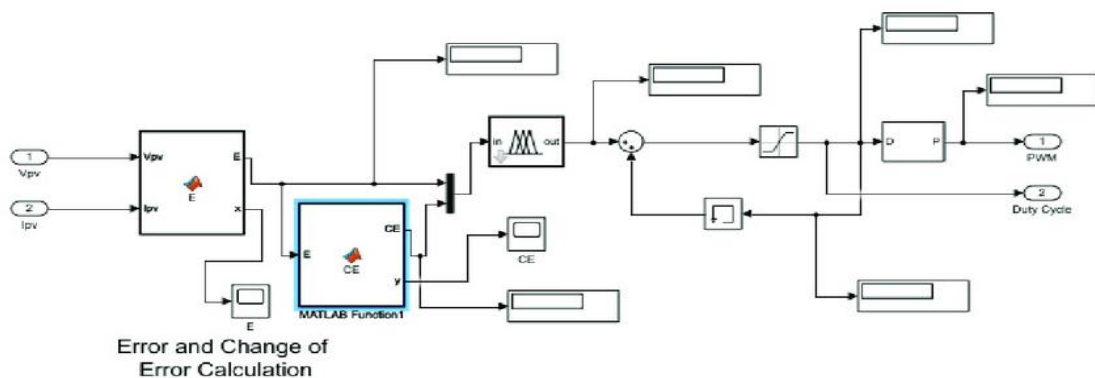

Figure 10-Hybrid ANN fuzzy Logic System For MPPT

Advantages of ANNs for MPPT

- **Robustness:** ANNs can handle dynamic environmental conditions and uncertainties in PV systems.



- **Fast Tracking:** They can quickly adapt to changes in solar irradiance and temperature, leading to faster tracking of the MPP.
- **High Efficiency:** ANN-based MPPT systems can achieve high efficiency, especially under varying environmental conditions.
- **Reduced Oscillations:** They can minimize oscillations around the MPP, leading to smoother power output.

4. Integration with Battery Management Systems

In solar PV systems with battery energy storage, effective coordination between the MPPT controller and the Battery Management System (BMS) is crucial. The BMS monitors the battery's health and ensures safe operation, while the MPPT controller maximizes power extraction.

Key Functions of the BMS:

- **State of Charge (SOC) Estimation:** Prevents overcharging and over discharging, enabling predictive maintenance.
- **Temperature Monitoring:** Ensures safe operating temperatures and prevents thermal runaway.
- **Voltage and Current Monitoring:** Maintains safe operating limits and prevents excessive current flows.

Interaction between MPPT and BMS:

The MPPT controller and BMS exchange information like battery SOC, voltage, current, and temperature to optimize system performance and battery longevity. Communication protocols like CAN, LIN, and I2C facilitate this interaction. Advanced integration strategies include predictive control and adaptive control.

5. Training Algorithms and Data Preprocessing

The performance of ANN-based MPPT controllers depends on the training process and data quality.

5.1 Training Algorithms

- **Backpropagation:** A widely used supervised learning algorithm that adjusts weights by propagating the error backward.
- **Levenberg-Marquardt (LM) Algorithm:** A powerful optimization technique combining gradient descent and Gauss-Newton methods.
- **Genetic Algorithms (GAs):** Employ a population of candidate solutions and genetic operators to evolve towards optimal solutions.
- **Particle Swarm Optimization (PSO):** Simulates the social behavior of bird flocks to explore the search space.

5.2 Data Preprocessing

- **Data Cleaning:** Handles missing values, outliers, and inconsistencies.
- **Data Normalization and Scaling:** Transforms data to a common scale for improved convergence.
- **Feature Selection:** Identifies and selects the most relevant features.
- **Data Augmentation:** Artificially increases the size of the training dataset.

6. Experimental Results and Comparative Analysis

Numerous studies have demonstrated the effectiveness of ANN-based MPPT controllers.

6.1 Faster Convergence

ANN-based MPPT controllers exhibit faster settling times and minimize energy loss compared to traditional methods.

6.2 Higher Efficiency

Improved power extraction and reduced losses contribute to higher overall system efficiency.

6.3 Enhanced Robustness

ANN-based controllers are less sensitive to parameter variations and noise, ensuring reliable operation.

Comparative Studies:



Simulation studies, Hardware-in-the-Loop (HIL) tests, and field tests have consistently shown the superior performance of ANN-based MPPT in terms of convergence speed, tracking accuracy, and robustness.

Challenges and Considerations:

- **Training Data Requirements:** Acquiring sufficient high-quality data can be challenging.
- **Complexity:** Designing and optimizing ANN architectures can be complex.
- **Computational Cost:** Training and implementing complex ANNs can be computationally expensive.

Addressing Challenges:

- **Data Augmentation Techniques:** Can be used to increase the size of the training dataset.
- **Efficient Training Algorithms:** Can reduce training time and computational cost.
- **Hardware Acceleration:** FPGAs, ASICs, and neuro-morphic computing can accelerate computation.

7. Future Research Directions

- **Deep Learning Architectures:** Exploring the use of CNNs and RNNs for enhanced performance.
- **Reinforcement Learning:** Developing adaptive and self-optimizing control policies.
- **Hardware Implementation:** Developing low-cost and energy-efficient hardware implementations.
- **Integration with IoT:** Enabling remote monitoring, control, and predictive maintenance.
- **Multi-Objective Optimization:** Balancing multiple objectives like energy extraction, battery degradation, and grid stability.
- **Advanced Machine Learning Techniques:** Exploring transfer learning and explainable AI.

8. Conclusion

ANN-based MPPT offers a promising approach for optimizing solar PV-battery-BLDC motor systems. The inherent advantages of ANNs, including their ability to learn, adapt, and converge rapidly, make them a valuable tool for enhancing efficiency, reliability, and sustainability. Continued research and development in this area will lead to further advancements, paving the way for more efficient and sustainable utilization of solar energy.

9. References:

- [1] Parida, B., Iniyar, S., &Goic, R. (2011). A review of solar photovoltaic technologies. *Renewable and sustainable energy reviews*, 15(3), 1625-1636. ¹
- [2] Femia, N., Petrone, G., Spagnuolo, G., & Vitelli, M. (2005). Optimization of perturb and observe maximum power point tracking method. *IEEE Transactions on Power Electronics*, 20(4), 963-973. ²
- [3] Kjaer, S. B., Pedersen, J. K., &Blaabjerg, F. (2005). A review of single-phase grid-connected inverters for photovoltaic modules. *IEEE Transactions on Industry³ Applications*, 41(5), 1292-1306. ⁴
- [4] Ishaque, K., Salam, Z., Lauss, G., &Shamsudin, A. (2012). A critical evaluation of maximum power point tracking techniques for photovoltaic systems. *Renewable and Sustainable Energy Reviews*, 16(4), 2559-2568.
- [5] Al-Amoudi, A. A., &Habaebi, M. H. (2010). A review of soft computing techniques for MPPT of photovoltaic systems. *Renewable and Sustainable Energy Reviews*, 14(9), 2953-2963.
- [6] Acarnley, P. P. (2007). *Stepping motors: a guide to theory and practice*. IET.
- [7] Krishnan, R. (2001). *Electric motor drives: modeling, analysis, and control*. Prentice hall.
- [8] Haykin, S. S. (2009). *Neural networks and learning machines*. Pearson Education.
- [9] Zhang, G., Patuwo, B. E., & Hu, M. Y. (1998). Forecasting with artificial neural networks:: The state of the art. *International journal of forecasting*, 14(1), ⁵ 35-62.
- [10] Figure 1-www.researchgate.net
- [11] Figure 2-blog.knoldus.com
- [12] Figure 3-arka360.com



[13] Figure 4- www.ablic.com

[14] Figure 5- www.researchgate.net

[15]Figure 6-www.researchgate.net

[16] Figure 7- www.geeksforgeeks.org

[17]Figure 8-www.researchgate.net

[18]Figure 9-www.researchgate.net

[19]Figure10-www.researchgate.net