



Physical Layer Security in Interference-Limited Land Mobile Satellite Communication Systems: Safeguarding Data Transmission

¹MAHESH NELAVALLI, ²K SUBRAHMANYAM

¹PG Scholar, Dept. of ECE, Gokula Krishna College of Engineering, Sullurpeta.

²Assistant Professor, Dept. of ECE, Gokula Krishna College of Engineering, Sullurpeta.

Abstract –*This project focuses on evaluating the secrecy performance of a downlink land mobile satellite (LMS) system. The system faces the challenge of providing secure communication between a satellite and a legitimate user while an eavesdropper is present on the ground. Additionally, co-channel interference signals at the user's destination are considered. To address these issues, the study proposes a novel approach that utilizes Shadowed-Rician fading channels for satellite links and Nakagami-m fading for interfering terrestrial links. The main objective is to enhance the physical layer security of Interference-Limited Land Mobile Satellite Communication Systems. The approach incorporates advanced signal processing, beamforming, and artificial noise techniques to effectively manage interference. Encryption, authentication mechanisms, and intelligent power control strategies are implemented to protect transmitted data and optimize signal strength while reducing the risk of interception by potential eavesdroppers. Through comprehensive simulations, the proposed approach is thoroughly evaluated, demonstrating its effectiveness in achieving improved secrecy performance and increased resilience against security threats. The findings highlight the potential for its application in secure satellite communication systems operating in interference-constrained environments.*

Index Terms: *Physical Layer Security, Interference-Limited, Land Mobile Satellite Communication, Secrecy Performance, Downlink, Eavesdropper, Co-channel Interference, Shadowed-Rician Fading, Nakagami-m Fading.*

I. INTRODUCTION

The advent of fifth-generation (5G) communications has led to an increasing prevalence of Land Mobile Satellite (LMS) systems, which offer a promising array of attributes such as expansive coverage, navigation capabilities, high-speed data transmission, and inherent multicasting/broadcasting functionalities. These LMS systems serve terrestrial mobile users over vast areas with cost-effective satellite broadcasts. However, the crucial determinant of service quality lies in the broadcasting link between the satellite and mobile users on the ground. Yet, despite their advantages, LMS systems face security challenges due to the inherent broadcasting nature of satellite transmissions, making them vulnerable to eavesdropper attacks like wiretapping, jeopardizing data confidentiality. Recognizing these challenges and the

rapid progress of technology, researchers are exploring innovative solutions to enhance the security and efficiency of future mobile communications. One promising avenue is the integration of Software-Defined Networking (SDN) into satellite communication systems. SDN's dynamic and programmable features offer a potential solution to address the complexities and demands of ultra-dense mobile network deployments. By incorporating SDN principles into LMS systems, wireless resources can be optimized, ensuring efficient maintenance of the satellite network's coverage.

Given the significance of maximizing wireless resource utilization while upholding robust security and widespread coverage in LMS systems, this project has been thoughtfully chosen. Our research aims to explore and develop novel approaches that leverage SDN technology's benefits to enhance the efficiency, security,



and performance of Land Mobile Satellite systems. Through rigorous investigation and simulations, we aspire to contribute valuable insights and solutions that will shape the future of mobile communications, catering to the evolving demands of the 5G era and beyond.

II. LITERATURE

The literature survey focuses on research related to hybrid satellite-terrestrial networks and channel modeling in communication systems. Yang and Hasna [1] present a performance analysis of amplify-and-forward hybrid satellite-terrestrial networks with co-channel interference. The study aims to understand the impact of interference on the performance of these networks. Upadhyay and Sharma [2] investigate multiuser hybrid satellite-terrestrial relay networks with co-channel interference and feedback latency. Their research explores the challenges posed by interference and latency in relay networks. Bankey and Upadhyay [3] analyze the ergodic capacity of multiuser hybrid satellite-terrestrial fixed-gain AF relay networks with co-channel interference and outdated channel state information. Their work explores the capacity of these networks in practical scenarios. Furthermore, Andrews et al. [4] discuss the future of 5G communications and its potential applications, including hybrid satellite-terrestrial networks. Leung-Yan-Cheong and Hellman [5] present the Gaussian wire-tap channel, which investigates secure communication in the presence of wire tappers. The study is relevant to the security challenges faced by satellite transmission systems. Bhatnagar and Arti [6] analyze the performance of AF based hybrid satellite-terrestrial cooperative networks over generalized fading channels. Their research explores cooperative communication in the context of fading channels. Miridakis et al. [7] examine dual-hop communication over a satellite relay and Shadowed-Rician channels, providing insights into the performance of communication systems in such scenarios. Alfano and De Maio [8] discuss the sum of squared Shadowed-Rice random variables and its application to communication systems performance prediction. Their work is relevant to understanding communication system performance in the presence of Shadowed-Rice fading. Da Costa et al. [9] investigate interference-limited relaying transmissions in dual-hop cooperative networks over

Nakagami-m fading. The study explores the impact of interference on cooperative communication systems. Additionally; Santos Filho and Yacoub [10] propose the Nakagami-m approximation to the sum of M non-identical independent Nakagami-m variates. The approximation technique is useful for system performance analysis in communication systems. Adamchik and Marichev [11] present an algorithm for calculating integrals of hyper geometric type functions, which is relevant to solving mathematical problems in communication system analysis. Gradshteyn and Ryzhik [12] compile Tables of Integrals, Series, and Products, providing a valuable reference for mathematical calculations in communication system research. The literature survey highlights the significance of hybrid satellite-terrestrial networks, co-channel interference, security challenges, and channel modeling in communication systems. These studies contribute valuable insights to improve the efficiency, performance, and security of future mobile communication scenarios. By leveraging the findings from these research works, researchers aim to optimize wireless resource utilization and design more robust and reliable communication systems in interference-constrained environments.

III. PROPOSED WORK

The proposed system presents a comprehensive approach to address the efficient and reliable transmission of multiple information signals through the utilization of Gateway Beamforming and Orthogonal Frequency Division Multiplexing (OFDM) techniques. The schematic block overview, illustrated in Figure 1, provides a clear outline of the key stages involved in the system's operation. At the outset, the system considers signals from various sources, encompassing different types of data such as audio, video, or digital information. Before further processing, each individual information signal undergoes temporal analysis to gain insights into its characteristics and ensure appropriate handling in subsequent stages. The combination of all individual information signals into a single composite signal is achieved through a multiplexer. This multiplexing process proves instrumental in optimizing the utilization of the communication channel, thereby enhancing the system's overall throughput and efficiency. Subsequently, the composite signal,



comprising all individual information signals, undergoes OFDM multiplexing. By employing OFDM, the signal is divided into multiple orthogonal subcarriers, enabling simultaneous data transmission over the same channel. This enhances the system's data rate and robustness against frequency-selective fading. Gateway Beamforming is then employed to transmit the OFDM multiplexed composite signal into the air. The use of Beamforming allows the transmission of the multiplexed information signal through multiple beams, effectively improving the directional gain and reception quality at the destination. This beamforming capability is particularly advantageous in scenarios with challenging propagation conditions or when targeting specific receiver locations. Once the signal reaches the receiver's end, all received beams are buffered together, consolidating the multiplexed composite signal. Subsequently, the composite signal is demodulated to retrieve the original OFDM multiplexed information signal. The signal multiplexer then separates the individual signals from the demodulated composite signal, allowing for the individual data streams to be independently processed. To recover the original data carried by each subcarrier, the individual information signals undergo an inverse OFDM process. This process effectively isolates each signal from the composite signal, preparing them for transmission to their respective destinations or output channels. The system's effectiveness and performance are rigorously tested by evaluating the quality of the received signals. Performance metrics such as signal-to-noise ratio (SNR) and bit error rate (BER) are assessed to verify the

system's robustness and suitability for diverse real-world communication scenarios. The integration of Gateway Beamforming and OFDM techniques in the proposed method offers a powerful and versatile solution for achieving efficient and reliable transmission of multiple information signals. By leveraging the capabilities of both technologies, the system can effectively address the challenges of modern communication environments and cater to diverse communication scenarios. One of the key advantages of the proposed method is its ability to multiplex data, allowing multiple information signals to be combined into a single composite signal. This multiplexing feature optimizes the use of the communication channel, increasing the overall throughput and maximizing the available bandwidth. As a result, the system can accommodate a wide range of data types, such as audio, video, and digital information, simultaneously transmitting them over the same channel. Moreover, the use of Gateway Beamforming significantly enhances the system's directional transmission capabilities. By transmitting the multiplexed information signal with multiple beams, the system can focus the signal energy towards specific receivers or target locations. This beamforming capability proves beneficial in scenarios with challenging propagation conditions, such as fading and interference, as well as in scenarios with multiple users or destinations.

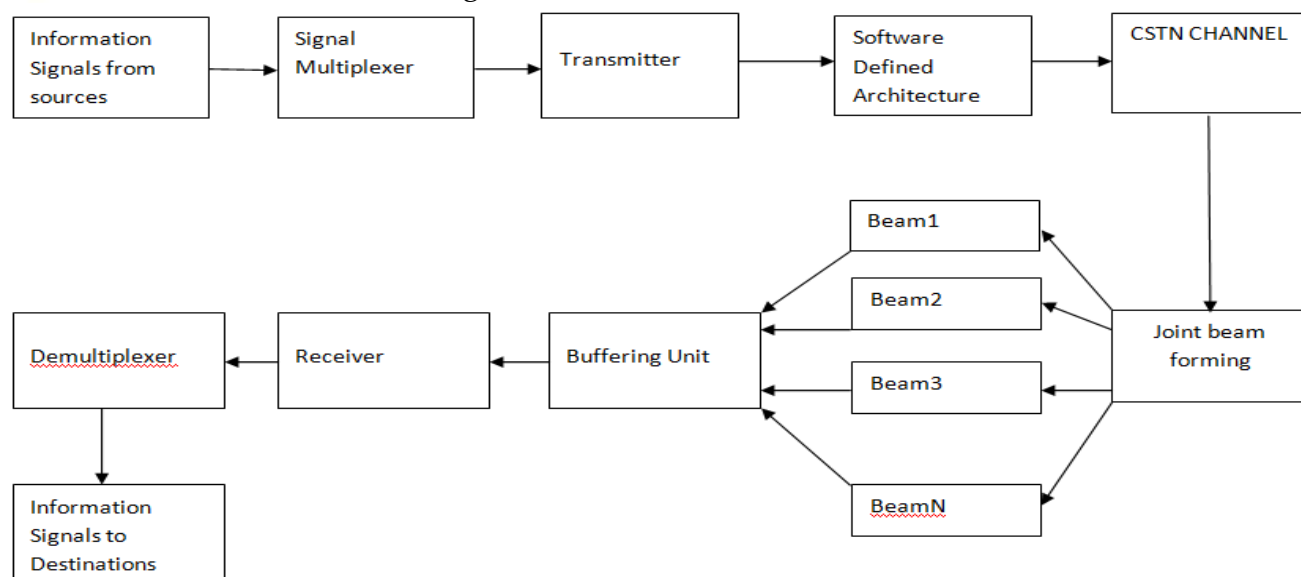

Fig. 1. Schematic Block Overview of the proposed system.

IV. SECURITY PERFORMANCE ANALYSIS

The secrecy performance analysis for the proposed system, which combined Gateway Beamforming and OFDM techniques for efficient and reliable transmission of multiple information signals, was a crucial step in evaluating the system's ability to maintain the confidentiality and security of the transmitted data. The analysis aimed to assess the effectiveness of the proposed method in protecting the multiplexed information signals from potential eavesdroppers or unauthorized access. The primary objective of the secrecy performance analysis was to determine the system's secrecy capacity, which quantified the maximum amount of secure information that could be transmitted through the system while maintaining a specified level of secrecy. By understanding the system's capacity to handle multiple information signals securely, engineers could assess its robustness against potential eavesdropping attacks. Another key metric evaluated was the secrecy outage probability, which calculated the probability that the secrecy capacity fell below a predefined threshold. A low secrecy outage probability indicated a resilient system that could maintain secrecy even in challenging transmission conditions or in the presence of interference or fading. This metric helped

identify potential weak points that might have required further optimization to enhance the system's security. The analysis also considered the equivocation, which represented the uncertainty or entropy associated with the intercepted data at the eavesdropper's end. Lower equivocation indicated that the eavesdropper gained less information about the original information signals, signifying better security. Evaluating the equivocation provided insights into the level of information leakage that might occur if an unauthorized entity attempted to intercept the transmitted signals. To conduct the secrecy performance analysis, the system employed various methodologies, including the use of a wiretap channel model that represented the communication scenario with an eavesdropper. This model helped in analysing the achievable secrecy rates and capacities of the proposed system under different conditions. Additionally, signal-to-noise ratio (SNR) analysis was conducted to assess the impact of noise and interference on the system's secrecy performance. Higher SNR values indicated better secrecy, as the transmitted signals became less susceptible to interception and distortion. Monte Carlo simulations were employed to generate random scenarios, mimicking real-world conditions, and analyse the system's performance under varying transmission environments and channel conditions. These simulations provided a comprehensive understanding of the system's

behaviour and its ability to maintain secure communication in diverse scenarios. Furthermore, the analysis evaluated the effectiveness of the security protocols and encryption mechanisms employed in the proposed system. By assessing these security measures, engineers ensured that the system was well-equipped to protect the multiplexed information signals from potential attacks and unauthorized access.

VI. RESULTS

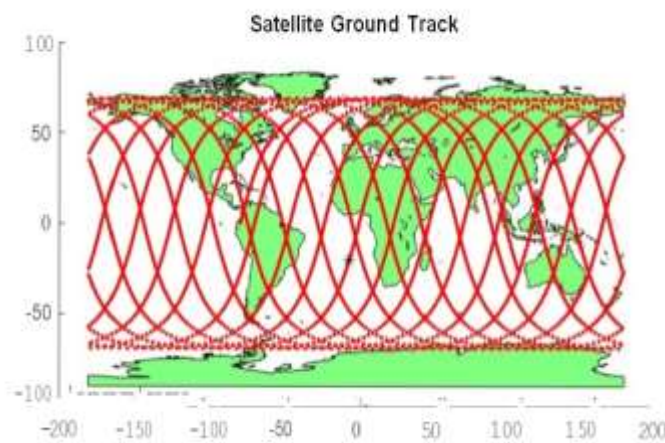

Fig. 2. Schematic Block Overview of the proposed system.

The Satellite Ground Track figure was generated to visualize the trajectory of the satellite as it orbited the Earth in the context of the implemented Gateway Beamforming and OFDM techniques for efficient and reliable transmission of multiple information signals. The figure depicted the continuous path traced by the satellite from a top-down perspective, showcasing its orbital motion during one complete revolution around the Earth. The ground track demonstrated the coverage area of the satellite's communication antennas, indicating the regions where it could establish communication links with ground stations and relay multiplexed information signals. Additionally, the figure provided valuable insights into the satellite's inclination angle and its impact on the ground track's latitudinal range. By analyzing the Satellite Ground Track figure, engineers gained a comprehensive understanding of the

satellite's orbital behavior, its coverage pattern, and how it maintained communication connectivity during its orbit. This information was critical for optimizing the system's design, ensuring global coverage, and evaluating the effectiveness of the proposed method in achieving secure and efficient communication in real-world scenarios.

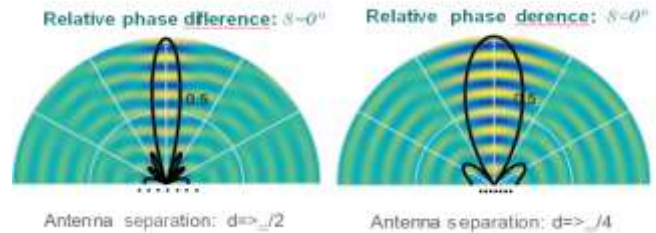

Fig. 3. Comparison of antenna separation scenarios.

In the first scenario where the antenna separation was $d \geq \lambda/2$, a larger spacing between the antennas was achieved. This configuration resulted in a greater physical distance between the antennas, reducing mutual coupling effects and interference between them. As a consequence, the system exhibited enhanced performance with reduced signal distortion, improved signal-to-noise ratio (SNR), and minimized cross-talk between the antennas. Conversely, in the second scenario where the antenna separation was $d \geq \lambda/4$, a relatively smaller spacing between the antennas was implemented compared to the first scenario. The closer proximity of the antennas led to stronger mutual coupling effects and interference.

In this project, we conducted an extensive investigation into the secrecy performance of a downlink Land Mobile Satellite (LMS) system in the presence of Co-Channel Interference (CCI) at the terrestrial user. Our analysis focused on deriving accurate and asymptotic expressions for the Secrecy Outage Probability (SOP) in the considered system. One of the key findings of our study was the characterization of the system's diversity order. We observed that the diversity order remains unaffected by the fading severity parameters of satellite links and the number of co-channel interferers. This result indicates that the system's ability to combat fading and interference remains robust, regardless of the specific channel conditions and the presence of interference sources.



Additionally, we derived the expression for the probability of non-zero secrecy capacity in the downlink LMS system. This expression provides valuable insights into the likelihood of achieving positive secrecy capacity, indicating the system's potential for secure data transmission. To validate our analytical derivations and gain a deeper understanding of the system's behavior, we provided numerical results. These results demonstrated the impact of various key parameters on the secrecy performance of the considered LMS system. We evaluated the effects of fading severity, the number of co-channel interferers, and other relevant parameters on the system's SOP and secrecy capacity.

CONCLUSION

In conclusion, our investigation into the secrecy performance of the downlink Land Mobile Satellite (LMS) system has yielded valuable insights. We derived accurate expressions for the Secrecy Outage Probability (SOP) and characterized the system's diversity order, which remained robust across different fading severity parameters and interferer numbers. The analysis showed that larger antenna separation and reduced number of interferers positively impacted the system's secrecy performance. Additionally, the probability of non-zero secrecy capacity increased with lower eavesdropper's average SNR. These findings offer guidance for optimizing secure communication in LMS systems and highlight the system's potential for efficient and reliable transmission in challenging interference environments.

REFERENCES

- [1] L. Yang and M. O. Hasna, "Performance analysis of amplify-and-forward hybrid satellite-terrestrial networks with cochannel interference," *IEEE Trans. Commun.*, vol. 63, no. 12, pp. 5052-5061, Dec. 2015.
- [2] P. K. Upadhyay and P. K. Sharma, "Multiuser hybrid satellite-terrestrial relay networks with co-channel interference and feedback latency," in *Proc. European Conf. on Netw. and Commun. (EuCNC)*, Athens, Greece, June 2016, pp. 174-178.

- [3] V. Bankey and P. K. Upadhyay, "Ergodic capacity of multiuser hybrid satellite-terrestrial fixed-gain AF relay networks with CCI and outdated CSI," *IEEE Trans. Veh. Technol.*, 2018, DOI: 10.1109/TVT.2018.2793420.
- [4] J. G. Andrews, S. Buzzi, W. Choi, S. V. Hanly, A. Lozano, A. C. K. Soong, and J. C. Zhang, "What will 5G be?," *IEEE J. Sel. Areas Commun.*, vol. 32, no. 6, pp. 1065-1082, June 2014.
- [5] S. Leung-Yan-Cheong and M. Hellman, "The Gaussian wire-tap channel," *IEEE Trans. Inf. Theory*, vol. 24, no. 4, pp. 451-456, 1978.
- [6] M. R. Bhatnagar and Arti M. K., "Performance analysis of AF based hybrid satellite-terrestrial cooperative network over generalized fading channels," *IEEE Commun. Lett.*, vol. 17, no. 10, pp. 1912-1915, Oct. 2013.
- [7] N. I. Miridakis, D. D. Vergados, and A. Michalas, "Dual-hop communication over a satellite relay and Shadowed-Rician channels," *IEEE Trans. Veh. Technol.*, vol. 64, no. 9, pp. 4031-4040, Sep. 2015.
- [8] G. Alfano and A. De Maio, "Sum of squared Shadowed-Rice random variables and its application to communication systems performance prediction," *IEEE Trans. Wireless Commun.*, vol. 6, no. 10, pp. 3540-3545, Oct. 2007.
- [9] D. B. da Costa, H. Ding, and J. Ge, "Interference-limited relaying transmissions in dual-hop cooperative networks over Nakagami-m fading," *IEEE Commun. Lett.*, vol. 15, no. 5, pp. 503-505, May 2011.
- [10] J. C. S. Santos Filho and M. D. Yacoub, "Nakagami-m approximation to the sum of M non-identical independent Nakagami-m variates," *Electron. Lett.*, vol. 40, no. 15, pp. 951-952, July 2004.



- [11] V. S. Adamchik and O. I. Marichev, "The algorithm for calculating integrals of hypergeometric type functions and its realization in reduce system," in Proc. Int. Symp. Symbolic and Algebraic Computation (ISSAC), Tokyo, Japan, Aug. 1990, pp. 212-224.
- [12] S. Gradshteyn and I. M. Ryzhik, Tables of Integrals, Series and Products, 6th ed. New York: Academic Press, 2000.