



## SMART CRADDLER USING IOT

**K.N.V.Satya Narayana**, Assistant Professor, ECE Department,  
**N.Venkata SaiKarthikReddy,P.Bhairava Swamy,M.Sudheer Babu, N.Rammohan** 4/4 SRKREC

### ABSTRACT:

Taking care of infants has become a daily struggle for many families as the number of working mothers has risen. Since parents frequently leave their infants in daycare centers or with grandparents, it is challenging for them to continuously check on their child's health. An IoT-based baby monitoring system (IoT-BMS) has been suggested as an efficient and reasonably priced method for real-time monitoring to address this issue. The goal of this project is to develop a complete system that enables parents to keep an eye on their infants from a distance. The system has capabilities including video monitoring, swinging the cradle automatically when the baby screams, sensing the amount of dampness in the baby's bed, and watching how close the infant is to the cradle. A Bluetooth module is used to relay all data to which the parents may see their child's movements on video using the Mit app, which also has a video capability. An Arduino UNO was used to create this system, enabling the fusion of several functions into a single system. This framework enables parents to interact with their children more individually even when they are not present physically. This paper offers a contemporary blessing for time-constrained parents by clearly describing the baby support system and its distinctive features. In conclusion, the IoT-based baby monitoring system offers a cutting-edge option for parents who wish to guarantee their children's safety and well-being even when they are not present in person.

**KEYWORDS:** Baby cradle, Gear motor, Voice module v3, Water sensor, DHT11 Sensor, Esp-32 cam, MIT app Inverter.

### INTRODUCTION:

In recent years, it has become customary in India for both parents to work. The hardest task for working parents right now will be baby monitoring. While they can provide care for the infant, it would be challenging for them to monitor the infant's health. Moreover, nearly one in ten infants are born preterm. particularly in nations with high infant mortality rates, IoT-powered smart cradles have emerged as a promising method to monitor and enhance the health of infants. Parents and medical experts can identify early symptoms of disease and take action before it's too late thanks to the ability of these cradles to track a variety of vital signs like breathing rate, heart rate, and temperature. Smart cradles can offer insightful information about a child's health and well-being by utilizing sensors and data analytics, potentially saving countless lives.

Using sensors and cameras, smart cradles can keep an eye on a variety of bodily functions and vital indications, including breathing rate, heart rate, and body temperature. Machine learning techniques are then used to examine the obtained data in order to look for any anomalies or probable health problems. This makes it possible for parents and medical experts to act quickly before the infant's condition deteriorates and poses a threat to his or her life.

Smart cradles can be a lifesaver for infants in environments with limited resources and access to healthcare. For instance, in India, where the newborn mortality rate is roughly 28 fatalities per 1,000 live births, a team of researchers created a low-cost, IoT-powered cradle that could track an infant's respiration, temperature, and humidity levels. A 50% decrease in hospitalizations resulted from the device's ability to identify the beginning of respiratory infections in infants before they got severe.

Smart cradles can also give parents insightful information about their child's health and growth. Healthcare specialists can spot patterns and trends in the sensor data that can predict the risk of developmental delays or other health problems. Better health outcomes can be achieved by allowing healthcare professionals to customize interventions and therapies to each infant's unique needs.

To sum up, IoT-powered smart cradles have the potential to transform newborn care, especially in environments with limited resources and access to healthcare. Smart cradles can lower newborn mortality rates and enhance the health of millions of infants globally by offering real-time monitoring and early diagnosis of health concerns.

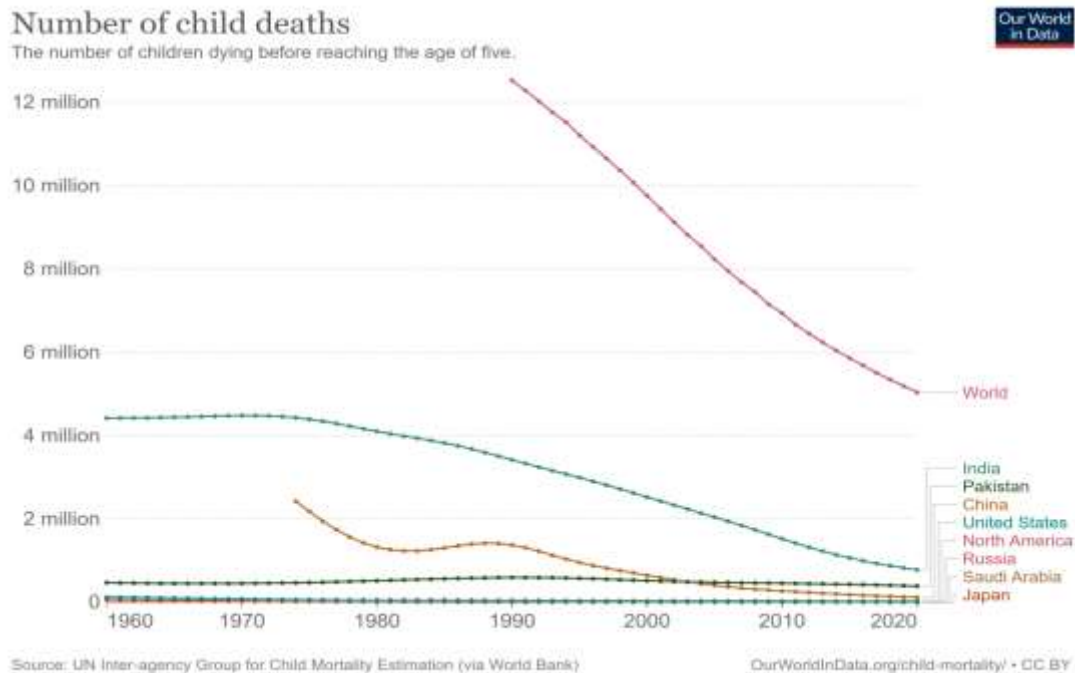

Fig1: Child Mortality Rate

## LITERATURE SURVEY:

[1] The automatic cradle system by Vijayamahantesh Hiremath, Dr. P. Vankataratnam [2017]: In this intelligent baby cradle system was developed. The cradle was capable of detecting the movement of the baby and initiate cradle swing. In addition, within the event of Bed wet or physiological condition, the developed device is capable of causing SMS. The device may be accustomed to minimize the work of the fogey and nurses in home and hospitals severally.

[2] Survey on Digital Age- Smarter Cradle-system for Enhanced Parenting by Sharmadha Senthil Nathan, Shivani Kanmani, Shruthi Kumar, Madheswari Kanmani [2018]: The system consists of automatic Rocking of the Baby Cradle, Detection of wet condition and detection of Temperature in Baby Cradle System. Cry analyzing system that detects the baby cry voice and consequently the cradle swings until the baby stops crying. The speed of the cradle may be controlled as per the user want. Wet sensor and temperature sensor are put in a diaper and it connects with mobile through a microcontroller. It may be harmful to the baby.

[3] IOT Based Baby Monitoring System for Smart Cradle by Waheb A. Jabbar, Senior Member, IEEE; Hiew Kuet Shang, Saidatul N. I. S. Hamid<sup>1</sup>; Akram A. Almohammed; Roshahliza M.

Ramli1, Member, IEEE and Mohammed A. H. Ali4, Member, IEEE [2017]: The system consists of a baby cradle that mechanically swings employing a motor once the baby cries in keeping with the sound device signal. Additionally, a mini fan mechanically opens to supply a cool temperature encompassing to the baby supported the temperature device. The oldsters will observe the traditional information recorded within the MQTT server cloud, like close temperature and remote switches, through the web visualization MQTT server, whereas the abnormal conditions are sent to the oldsters with triggering alarm to require acceptable actions. The oldsters also can monitor the baby's condition through Associate in The nursing external net camera and put on the lullaby toy settled on the baby's cradle remotely via the MQTT server to entertain the baby.

[4] Smart Cradle by Natheera, S. Sundaravadeivel, N. L. Visakan, S. Viswanathan and M. Vivekkumar [2018]: In this system a module used to detect the cry of the baby and it connected with Arduino Uno. The baby cries then the mechanically wiegenswing are activated. The wet sensing element results a Boolean price either true or false indicating whether or not the bed within the cradle is wet or not. The integrated camera module is employed to show the video of baby throughout any abnormality. All are connect with Arduino Uno

**PROPOSED SYSTEM:**

**SYSTEM ARCHITECTURE:**

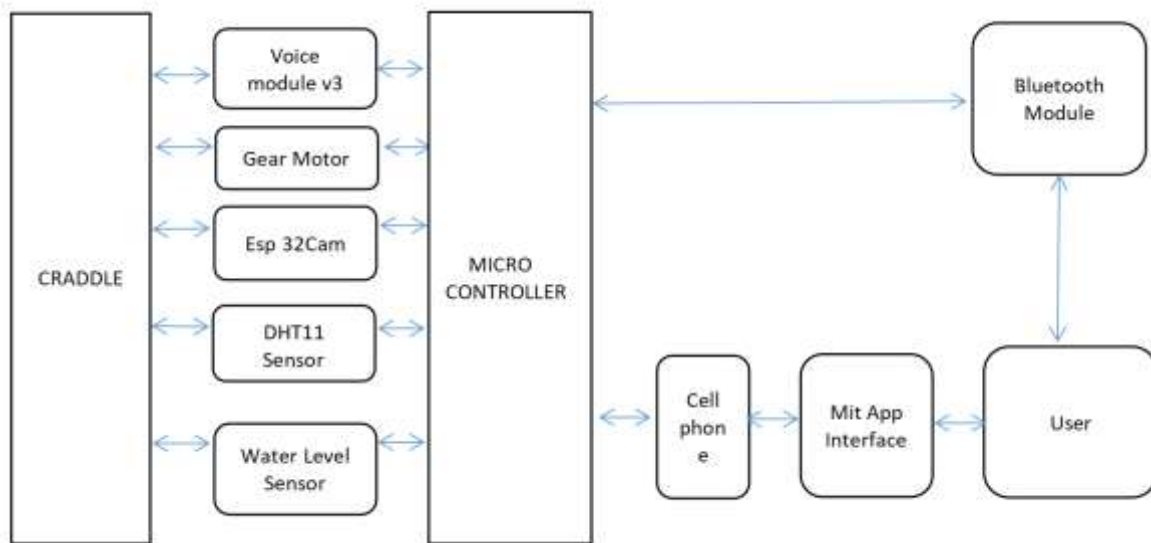

Fig 2: System Architecture

**HARDWARE USED AND ITS DESCRIPTION:**

**Voice Module v3:**

The Voice Module V3 is a device designed to provide voice-based functionality to various electronics projects. It is a small, programmable module that can recognize and respond to voice commands using advanced speech recognition technology. The module is equipped with a high-quality microphone that can pick up sounds from a distance, even in noisy environments. It also has a built-in speaker that can play back recorded audio or synthesized speech. One of the standout features of the Voice Module V3 is its ease of use. It comes with pre-programmed commands and



can be easily customized to recognize new commands. Additionally, it can be integrated with a variety of microcontrollers and development boards, making it a versatile tool for a wide range of projects.

### **Gear Motor:**

A gear motor is a type of motor that includes a gear train, which helps to increase the torque output and reduce the speed of the motor. The gear train consists of gears of different sizes that are meshed together to transfer power from the motor to the output shaft.

Product Name: Gear Box Motor

Rated Voltage: 12V; Rated Current: 0.15A; Speed: 120RPM.

Reduction Ratio: 1:40.6; Rated Torque: 3.6Kg.cm; Shaft Diameter: 6mm(0.24")

Mounting Hole Size: M3; Motor Size: 36mm x 33mm(1.4" x 1.3")(D\*L)

### **Esp32 cam:**

The ESP32-CAM is a low-cost, low-power, Wi-Fi enabled camera module based on the ESP32 microcontroller. It features a OV2640 2MP camera sensor, a built-in antenna, and a microSD card slot for storing images and video. One of the key advantages of the ESP32-CAM is its ability to connect to Wi-Fi networks, allowing it to stream video and images over the internet. It also supports Bluetooth and BLE connectivity, which can be useful for building wireless control interfaces. Overall, the ESP32-CAM is a powerful and versatile camera module that offers a wide range of features at a low cost, making it an attractive option for developers and hobbyists looking to build connected camera applications

### **DHT11 SENSOR:**

The DHT11 is a low-cost, digital temperature and humidity sensor that uses a thermistor and a capacitive humidity sensor to measure environmental conditions. It has a simple 3-pin interface and is commonly used in DIY projects and home automation systems. Its accuracy is limited, but it is a cost-effective option for basic temperature and humidity sensing applications.

### **Water Level Sensor:**

A water level sensor is an electronic device used to detect and measure the level of water in a tank or other container. It works by sending a signal to a control system when the water level reaches a predetermined level. Water level sensors can be used for a variety of applications, including irrigation systems, water tanks, and industrial processes.

### **Bluetooth Module:**

A Bluetooth module is a small electronic device that allows wireless communication between devices using Bluetooth technology. It typically consists of a radio transceiver and a microcontroller, and can be easily integrated into electronic devices. Bluetooth modules are commonly used in wireless audio, Internet of Things (IoT) devices, and other applications that require short-range wireless communication.

## **SOFTWARE USED AND ITS DESCRIPTION:**

### **MIT APP INVERTER:**

MIT App Inventor is a web-based platform for building Android mobile applications using a block-based programming interface. It is designed to be accessible to beginners and non-programmers,



allowing them to create functional apps with minimal coding knowledge. The platform is open-source and free to use.

## **METHODOLOGY:**

### **MODULES:**

#### **MODULE 1:**

##### **Automatic cradle swinging:**

The cradle will start swinging when the baby is crying which is detected with the help of voice module v3.

Step1: Start

Step 2: Check if the baby is crying.

Step 3: If the sound is detected then the cradle starts swinging automatically, and also we have an option to the movement of the cradle with the help of an app.

Step 4: If no sound is detected then ends.

#### **MODULE 2:**

##### **Temperature :**

Temperature sensor helps in finding the body temperature of the baby. It checks the body temperature of the baby and gives a red mark indication in the app when the temperature increases.

Step 1: Start

Step 2: Check if body temperature changes rapidly.

Step 3: If a temperature change is detected then it gives indications in the app with the help of colors. (green color refers to normal temperature, Yellow color indicates a slight increase in temperature, and Red color indicates High temperature.

Step 4: If no temperature is detected then ends.

#### **MODULE 3:**

##### **Wetness :**

Baby wetness can be identified by a water level sensor. A water level sensor continuously keeps on checking whether the baby's mattress is wet or not. When then wetness is sensed then parents are intimated by indicating the color of the wetness value in the app. The system helps in keeping the baby in a Hygienic environment.

Step 1: Start

Step 2: Check if the Mattress is wet

Step 3: If wetness is detected then it indicates the value of wetness in the app.

Step 4: If no wetness is detected then ends.

#### **MODULE 4:**

##### **Continuous Baby Surveillance:**

Step 1:With the help of Esp 32 cam baby is viewed lively from any place.

Step 2:Esp 32 has an inbuilt object detection mechanism with that we can easily track babies.

Step 3: We can easily track baby movements with the help of the App, which is very useful, especially for working women.

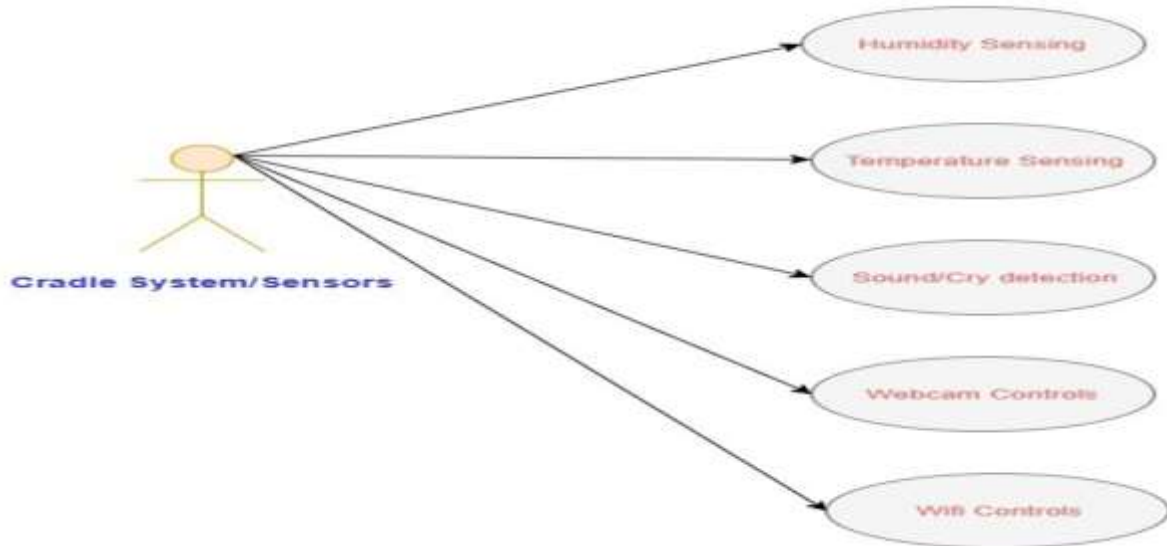

Fig 3: Complete surveillance of the baby with the help of the App

**FLOW CHART:**

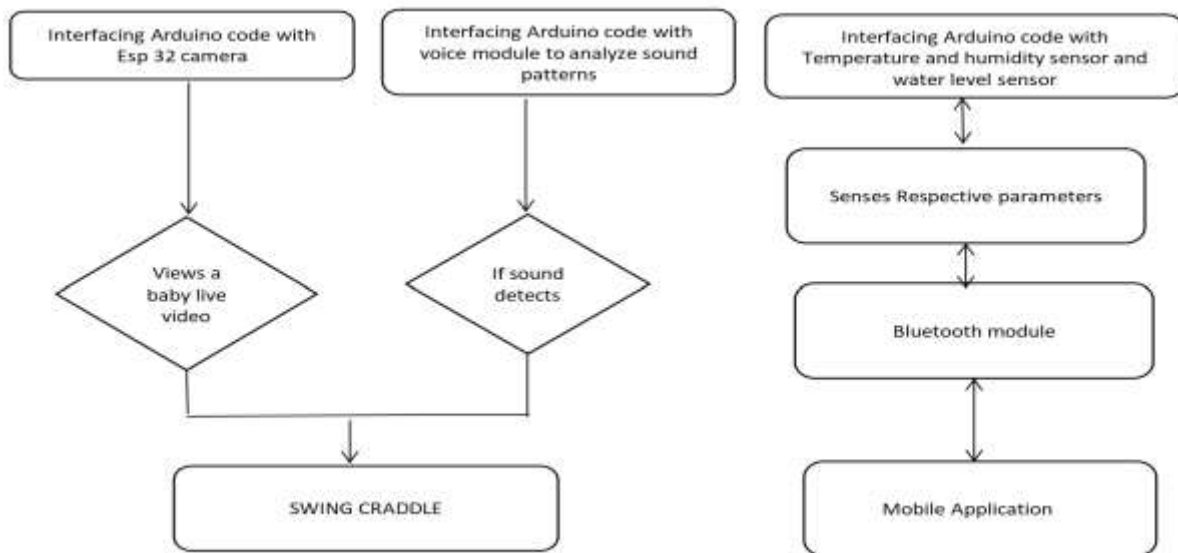

Fig 4: Flow chart of smart cradle using Iot

**RESULTS:**



Fig 5:MIT APP INTERFACE



Fig 6:Face detection with the help of Esp 32 cam

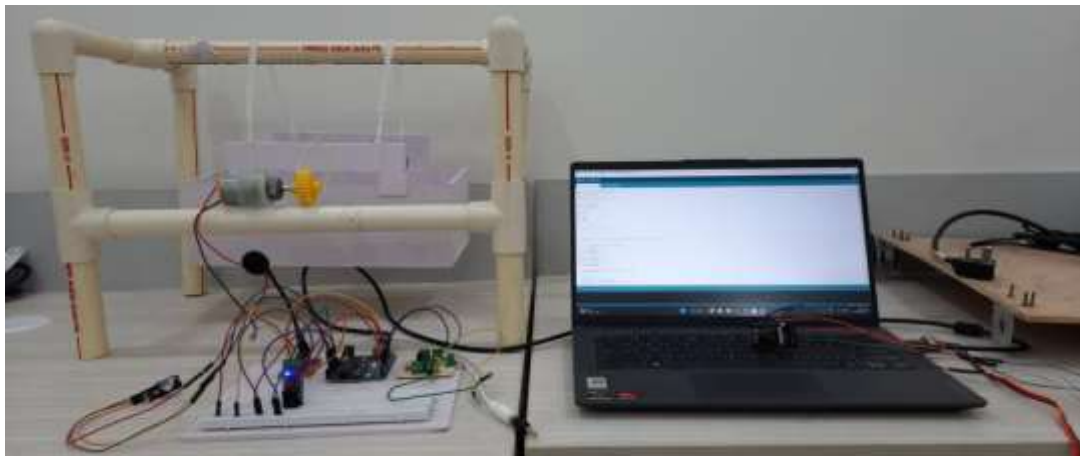

Fig 7:setup of all the components of the project

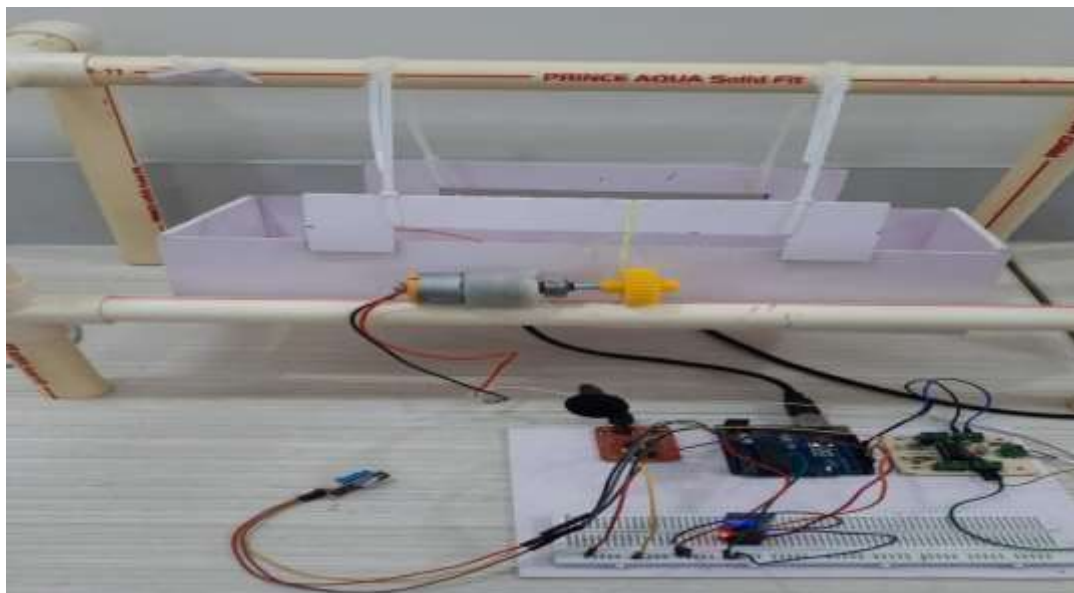

Fig 8:The figure shows cradle movement when the baby starts crying

## CONCLUSION:

In conclusion, using an IoT-enabled smart cradle can offer parents and carers a variety of advantages. The baby's temperature, movement, and sleeping habits can all be tracked by the smart cradle, which can also send real-time updates to the parents' smartphones. Additionally, it can play lullabies and calming music to put the baby to sleep, and it can even alter the cradle's rocking motion to suit the infant's tastes. To make the baby's environment more cozy and secure, IoT technology can also be linked with other smart home appliances, such as smart lighting and thermostats. Overall, an IoT-enabled smart cradle can improve the standard of care for infants and make parenting simpler and more practical for carers.





## **FUTURE SCOPE:**

IoT-based smart cradles can have a wide range of characteristics, but some of the more significant and practical ones might be as follows:

**Sleep tracking:** The baby's sleeping patterns, including length of sleep, frequency of awakenings, and level of sleep, can be tracked by the smart cradle. To better understand their baby's sleeping patterns, parents can have this information transmitted to their smartphones. **Monitoring of temperature and humidity:** The smart cradle can keep an eye on the temperature and humidity levels in the room and change its environment as necessary to keep the infant safe and comfortable.

**Control of the cradle's rocking motion:** The smart cradle can learn from previous settings and adapt its rocking motion based on the baby's preferences.

**Remote access and control:** Parents may monitor and change settings on the smart cradle even when they are not in the same room as it is by using a smartphone app.

**Integration with other smart home appliances:** To give the infant a more cozy and secure environment, the smart cradle may be integrated with other smart home appliances like smart lighting and thermostats. The smart cradle can monitor the baby's motions and sounds, and it can also inform the parents if anything seems out of the norm. The smart cradle can play several lullabies and other calming noises to aid in the baby's relaxation and sleep.

An IoT-powered smart cradle with these capabilities can give parents and carers more peace of mind and improve the standard of care for the infant overall.

## **REFERENCES:**

- [1] Jabbar, W.A., Shang, H.K., Hamid, S.N., Almohammed, A.A., Ramli, R.M. and Ali, M.A., 2019. IoT-BBMS: Internet of Things-based baby monitoring system for smart cradle. *IEEE Access*, 7, pp.93791-93805.
- [2] Joshi, M.P. and Mehetre, D.C., 2017, August. IoT based smart cradle system with an Android app for baby monitoring. In 2017 International Conference on Computing, Communication, Control and Automation (ICCUBEA) (pp. 1-4). IEEE.
- [3] Joseph, S., Kumar, A. and Babu, M.H., 2021, March. IOT based baby monitoring system smart cradle. In 2021 7th International Conference on Advanced Computing and Communication Systems (ICACCS) (Vol. 1, pp. 748-751). IEEE.
- [4] Satyanarayana, K.N.V., Reddy, S.R.N., Varma, K.S. and Raju, P.K., 2017. Mobile app & iot based smart weather station. *International Journal of Electronics, Communication and Instrumentation Engineering Research and Development (IJEIERD)*, 7(4), pp.1-8.
- [5] Satyanarayana, K.N.V., Yaswanthini, G., Kartheeka, P.L., Rajkumar, N. and BhimaRaju, A., 2018. IoT based vehicle speed control automatically in restricted areas using RFID. *Int J Eng Technol*, 7(3.31), pp.72-74.
- [6] Satyanarayana, K.N.V., Reddy, S.R.N., Teja, P.S. and Habibuddin, M.B., 2016. IoT based smart weather station using Raspberry-PI3. *Journal of Chemical and Pharmaceutical Sciences*, 2016(10), pp.1-6.
- [7] Pratap, N.L., Anuroop, K., Devi, P.N., Sandeep, A. and Nalajala, S., 2021, January. Iot based smart cradle for baby monitoring system. In 2021 6th International Conference on Inventive Computation Technologies (ICICT) (pp. 1298-1303). IEEE.
- [8] Durga, S., Itnal, S., Soujanya, K., Basha, C.Z. and Saxena, C., 2021, October. Advanced and effective baby care monitoring Smart cradle system using Internet of Things. In 2021 2nd International Conference on Smart Electronics and Communication (ICOSEC) (pp. 35-42). IEEE.